



**TC-TXC 250-450-510/2008**

**TE 250-450-510/2008-I.E.**

**SMR 450-510/2008-I.E.**

**Part. N° 8000B0149 Ed.03-2014**



**INFORMAZIONI GENERALI**

Il presente catalogo serve per richiedere con esattezza le parti di ricambio  
Nelle ordinazioni indicare:

- 1) il numero di codice dei particolari seguito dalla descrizione;
  - 2) il colore per i pezzi verniciati o comunque colorati;
  - 3) il numero di matricola del motociclo, stampigliato sul canotto di sterzo.
- Le indicazioni destra e sinistra si riferiscono ai lati del veicolo rispetto al senso di marcia;

**GENERAL INFORMATION**

The present spare parts list enables one to order exactly the right spare parts.

When ordering specify:

- 1) the part's code number followed by its description;
  - 2) indicate colour for painted or coloured parts;
  - 3) the motorcycle's serial number, stamped on the steering head.
- References to right and left apply to the vehicle in terms of its direction of movement.

**INFORMATIONS GENERALES**

Ca catalogue permet de commander correctement les pièces de rechange.  
Les commandes doivent être passées en indiquant:

- 1) le numéro de code des pièces détachées suivi de leur description;
  - 2) le couleur des pièces peintes ou colorés;
  - 3) le matricule de la moto, estampillé sur la tige du guidon.
- Droite et gauche sont les côtés du véhicule par rapport au sens de la marche.

**ALLGEMEINE HINWEISE**

Dieser Ersatzteilkatalog dient zur genauen Angabe der Teile bei Ersatzteilbestellungen.

Bei Ersatzbestellung ist folgendes anzugeben:

- 1) Die Bestellnummer der Ersatzteile mit der entsprechenden Beschreibung;
  - 2) Farbe für lackierte und farbige Teile angeben;
  - 3) Die Sseriennummer des Motorrads, die am Lenkrohr eingepreßt ist.
- Die Angaben rechts und links beziehen sich auf das Fahrzeug in Fahrriichtung.

**INFORMACIONES GENERALES**

El presente catálogo sirve para pedir con exactitud las partes de recambio.  
En los pedidos se debe indicar:

- 1) el número de código de la parte y a continuación la descripción;
  - 2) el color para las piezas barnizadas o coloreadas;
  - 3) el número de matrícula de la motocicleta, estampado en el tubo de dirección.
- Las indicaciones derecha e izquierda se refieren a los lados del vehículo respecto del sentido de marcha.

**NOTE - LIST - NOTES - NOTE - NOTAS:**

- A** : In alternativa - In alternative - En alternative - Wahlweise - En alternativa  
**C** : Modello **TC - TC** model - Modèle **TC** - Modell **TC** - Modélo **TC**  
**D** : In dotazione - To issue - En nécessaire - Ausrüstungsteile - En dotación  
**E** : Ad esaurimento - To fell out - A' finir - Erschöpfung - A agotamiento  
**F** : Fornire assieme - Supply unitedly - Fournir ensemble - Wird zusammen geliefert Equipar juntos  
**H** : Potenziamento per uso sportivo su circuito di gara - Powering for racing use on circuit - Augmentation de la puissance pour usage sportif sur piste - Potenzierung für wettkämpferischen Gebrauch des Motorrad - Aumento de la potencia para uso agonístico sobre circuito de competición  
**M** : Modello **SMR- SMR** model - Modèle **SMR** - Modell **SMR** - Modélo **SMR**  
**N** : Non fornito - Not supplied - Ne pas fournir - Keine Gelieferende - No equiparado  
**Ø** : Non per JPN - Not for JPN - Ne pas pour JPN - Keine für JPN - No por JPN  
**P** : Non per SMR - Not for SMR - Ne pas pour SMR - Keine für SMR - No por SMR  
**Q** : Solo per SMR / U.S.A. - Only for SMR / U.S.A. - Soulement pour SMR / U.S.A. Nur für SMR / U.S.A. - Solo por SMR / U.S.A.  
**R** : A richiesta - Upon request - Sur demande - Auf anfrage - a pedimento  
**S** : Di serie - Supplied - De série - Standard - De serie  
**T** : Modello **TXC- TXC** model - Modèle **TXC** - Modell **TXC** - Modélo **TXC**  
**U** : Solo per TE/ U.S.A. - Only for TE/ U.S.A. - Soulement pour TE/ U.S.A. Nur für TE/ U.S.A. - Solo por TE/ U.S.A.  
**X** : Non per U.S.A. - Not for U.S.A. - Ne pas pour U.S.A. - Keine für U.S.A. - No por U.S.A.  
**XB** : Non per BR - Not for BR - Ne pas pour BR - Keine für BR - No por BR  
**Y** : Non per TC - Not for TC - Ne pas pour TC - Keine für TC - No por TC  
**W** : Modello **TE- TE** model - Modèle **TE** - Modell **TE** - Modélo **TE**  
**Z** : n° denti, number of teeth, numéro dents, Zähne nummer - número dientes

- A** : Austria, Austria, Autriche, Österreich, Austria  
**AUS** : Australia, Australia, Australie, Australien, Australia  
**B** : Belgio, Belgium, Belgique, Belgien, Bélgica  
**BR** : Brasile, Brazil, Brasile, Brasilien, Brasil  
**CDN** : Canada, Canada, Canada, Kanada, Canadá  
**CH** : Svizzera, Switzerland, Suisse, Schweizer, Suiza  
**D** : Germania, Germany, Allemagne, Deutschland, Alemania  
**E** : Spagna, Spain, Espagne, Spanien, España  
**F** : Francia, France, France, Frankreich, Francia  
**GB** : Gran Bretagna, Great Britain, Grand Bretagne, Groos Britan, Gran Bretaña  
**I** : Italia, Italy, Italie, Italien, Italia  
**J** : Giappone, Japan, Japon, Japan, Japón  
**SF** : Finlandia, Finald, Finlande, Finland, Finlandia  
**USA** : Stati Uniti d'America, United States of America, Etats Units d'Amerique, Vereinigte Staaten von Amerika, Estados Unidos

Dati indicativi soggetti a modifiche senza impegno di preavviso.  
All data are subject to modification without prior notice.  
Données indicatif sujet au modifications sans obligation de préavis.

N° DI MATRICOLA INIZIALE - INITIAL SERIAL NUMBER - MATRICULE INITIAL - BEGINNTESERIENNUMMER - MATRICULA INICIAL	
MODELLO - MODEL MODELE - MODELL MODELO	MATRICOLA - SERIAL NUMBER MATRICULE - SERIENNUMMER MATRICULA
TC 250/2008	ZKHA200AA8V050001
TC 450/2008	ZKHA202AA8V050001
TC 510/2008	ZKHA202AB8V000001
TE 250/2008	ZKHA200AA8V000001
TE 450/2008	ZKHA202AA8V000001
TE 510/2008	ZKHA203AA8V000001
TE 250/2008 USA	ZKHECECA*8V100001
TE 450/2008 USA	ZKHECENB*8V100000
TE 510/2008 USA	ZKHECEHB*8V100000
TXC 250/2008 USA	ZKHTX250*8V000001
TXC 450/2008 USA	ZKHTX450*8V000001
TXC 510/2008 USA	ZKHTX510*8V000001
SMR 450/2008	ZKHA202AB8V000001
SMR 510/2008	ZKHA203AB8V000001

Codice colore **G**: versione "ROSSO - BIANCO - NERO"  
Color code **G**: "RED - WHITE - BLACK" version  
Code couleur **G**: version "ROUGE - BLANC - NOIR"  
Code Farbe **G**: "ROT - WEISSE - SCHWARZ" Version  
Código de color **G**: moto "ROJO - BLANCO - NEGRO"

Anderungen Vorbehalten.  
Datos indicativos sujetos a modificaciones sin compromiso de preaviso.

Tavola Drawing Table Bild Tabla	Denominazione	Description	Designation	Bezeichnung	Denominacion	Pagina Page Page Seite Paja
1	ATTREZZI DI ASSISTENZA, MANUALI E CATALOGHI	SERVICE TOOLS, MANUALS AND CATALOGS	OUTILS D'ASSISTANCE, MANUELS ET CATALOGUES	HILFAUSRUSTUNG, HANDBUCH UND KATALOG	HERRAMIENTAS DE ASISTENCIA, MANUALES Y CATALOGOS	15
3	CILINDRO, PISTONE	CYLINDER, PISTON	CYLINDRE, PISTON	ZYLINDER, KOLBEN	CILINDRO, PISTON	21
4	TESTA CILINDRO	CYLINDER HEAD	CULASSE	ZYLINDERKOPF	CULATA	27
5	MANOVELLISMO	CRANKSHAFT	VILEBREQUIN	KURBELWELLE	CIGÜEÑAL	35
6	TRASMISSIONE PRIMARIA, FRIZIONE	PRIMARY DRIVE, CLUTCH	TRANSMISSION PRIMAIRE, EMBRAYAGE	PRIMÄRÜBERSETZUNG, KUPPLUNG	TRANSMISION PRIMARIA, EMBRAGUE	37
7	DISTRIBUZIONE	VALVE TIMING	DISTRIBUTION	VENTILSTEUERUNG	DISTRIBUCION	41
8	SEMICARTER SINISTRO	L.H. HALF CRANKCASE	CARTER G.	GEHAUSEDECKEL L.	BANCADA IZQ.	45
9	SEMICARTER DESTRO	R.H. HALF CRANKCASE	CARTER D.	GEHAUSEDECKEL R.	BANCADA DER.	49
10	COPERCHI SEMICARTER DX	R.H. HALF CRANKCASE COVERS	COUVERCLES CARTER D.	GEHAUSEDECKEL R.	TAPAS BANCADA DER.	53
11	COPERCHI SEMICARTER SX	L.H. HALF CRANKCASE COVERS	COUVERCLES CARTER G.	GEHAUSEDECKEL L.	TAPAS BANCADA IZQ.	55
12	LUBRIFICAZIONE	OIL PUMP	PUMPE HUILE	MOTORSCHMIERUNG	LUBRICACION	57
13	CARBURATORE KEIHIN <b>(TC-TXC)</b>	CARBURETOR KEIHIN <b>(TC-TXC)</b>	CARBURATEUR KEIHIN <b>(TC-TXC)</b>	VERGASER KEIHIN <b>(TC-TXC)</b>	CARBURADOR KEIHIN <b>(TC-TXC)</b>	61
13A	CORPO FARFALLATO "MIKUNI" <b>(TE-SMR)</b>	"MIKUNI" THROTTLE BODY <b>(TE-SMR)</b>	CORP PAPILLON "MIKUNI" <b>DE VITESSE (TE-SMR)</b>	DROSSELKLAPPENKÖRPER "MIKUNI" <b>GANGSCHALTUNG (TE-SMR)</b>	CUERPO OSCILANTE "MIKUNI" <b>(TE-SMR)</b>	65
14	PARTE ELETTRICA	IGNITION SYSTEM	PARTIES ELECTRIQUE	ELEKTRISCHE TEILE	PARTE ELECTRICA	67
15	AVVIAMENTO	STARTING	DEMARRAGE	ANLASSER	ARRANQUE	71
16	CAMBIO, COMANDO CAMBIO <b>(TC)</b>	TRANSMISSION, SHIFTER <b>(TC)</b>	BOITE DE VITESSE, COMMANDE <b>DE VITESSE (TC)</b>	WECHSELGETRIEBE, <b>GANGSCHALTUNG (TC)</b>	CAMBIO, MANDO CAMBIO <b>(TC)</b>	75
16A	CAMBIO, COMANDO CAMBIO <b>(TE-TXC-SMR)</b>	TRANSMISSION, SHIFTER <b>(TE-TXC-SMR)</b>	BOITE DE VITESSE, COMMANDE <b>DE VITESSE (TE-TXC-SMR)</b>	WECHSELGETRIEBE, <b>GANGSCHALTUNG (TE-TXC-SMR)</b>	CAMBIO, MANDO CAMBIO <b>(TE-TXC-SMR)</b>	81
17	RAFFREDDAMENTO	COOLING SYSTEM	REFROIDISSEMENT	WASSERKÜHLUNG	ENFRIAMIENTO	87
18	FILTRO ARIA	AIR FILTER	FILTRE AIRE	LUFTFILTER	FILTRO DE AIRE	91
19	TELAIO, PEDANE	FRAME, FOOT RESTS	CADRE, REPOSE PIEDS	RAHMEN, FUSSBRETT	BASTIDOR, REPOSAPIES	93
20	SOSPENSIONE ANTERIORE <b>(TE-SMR)</b>	FRONT FORK ASSEMBLY <b>(TE-SMR)</b>	SUSPENSION AVANT <b>(TE-SMR)</b>	VORDERTELESKOPGABEL <b>(TE-SMR)</b>	SUSPENSION DELANTERA <b>(TE-SMR)</b>	97
20A	SOSPENSIONE ANTERIORE <b>(TC-TXC)</b>	FRONT FORK ASSEMBLY <b>(TC-TXC)</b>	SUSPENSION AVANT <b>(TC-TXC)</b>	VORDERTELESKOPGABEL <b>(TC-TXC)</b>	SUSPENSION DELANTERA <b>(TC-TXC)</b>	103
21	FORCELLONE POSTERIORE	REAR SWING ARM	FOURCHE ARRIÈRE	HINTERGABEL	HORQUILLA TRASERA	109
22	AMMORTIZZATORE POSTERIORE	REAR SHOCK ABSORBER	AMMORTISSEUR ARRIÈRE	HINTERSTOSSDAMPFER	AMORTIGUADOR TRASERO	113
23	LEVERAGGI SOSPENSIONE POSTERIORE	REAR SUSPENSION LINKAGE	LEVIER SUSPENSION ARRIERE	HEBELWERK HINTERHAUFHANGUNG	PALANCA SUSPENSION TRASERA	117
24	MANUBRIO E COMANDI	HANDLEBAR AND CONTROLS	GUIDON ET COMMANDES	LENKER UND STEUERORGANE	MANILLAR Y MANDOS	119

Tavola Drawing Table Bild Tabla	Denominazione	Description	Designation	Bezeichnung	Denominacion	Pagina Page Page Seite Paja
25	FRENO IDRAULICO POSTERIORE	REAR HYDRAULIC BRAKE	FREIN HYDRAULIQUE ARRIERE	HINTERBREMSE	FRENO HIDRAULICO TRASERO	123
26	PANNELLI LATERALI, PORTATARGA PARAFANGHI, SELLA	SIDE PANELS, FENDERS, SEAT, PLATE HOLDER	PANNEAU, GARDE-BOUES, SIEGE, PORTE-BALAI	STREIFEN, KOTFLUGEL, SATTEL SCHILDTRÄGER	PANELES, GUARDABARROS, SILLIN, PORTAMATRICULA	125
27	SERBATOIO CARBURANTE, CONVOGLIATORI	GAS TANK, PANELS	RESERVOIR CARBURANT, FLANCS	KRAFTSTOFFBEHALTER, FLANKE	DEPOSITO GASOLINA, LATERALES	129
28	SCARICO	EXHAUST SYSTEM	TUYAU D'ECHAPPEMENT	AUSPUFFROHR	TUBO DE ESCAPE	133
29	FRENO IDRAULICO ANTERIORE <b>(TE, TC, TXC)</b>	FRONT HYDRAULIC BRAKE <b>(TE, TC, TXC)</b>	FREIN HYDRAULIQUE AV. <b>(TE, TC, TXC)</b>	VORTERBREMSE <b>(TE, TC, TXC)</b>	FRENO HIDRAULICO DELANTERO <b>(TE, TC, TXC)</b>	137
29A	FRENO IDRAULICO ANT. <b>(SMR)</b>	FRONT HYDRAULIC BRAKE <b>(SMR)</b>	FREIN HYDRAULIQUE AV. <b>(SMR)</b>	VORTERBREMSE <b>(SMR)</b>	FRENO HIDRAULICO DEL. <b>(SMR)</b>	139
30	RUOTA ANTERIORE <b>(TE, TC, TXC)</b>	FRONT WHEEL <b>(TE, TC, TXC)</b>	ROUE AVANT <b>(TE, TC, TXC)</b>	VORTERRAD <b>(TE, TC, TXC)</b>	RUEDA DELANTERA <b>(TE, TC, TXC)</b>	141
30A	RUOTA ANTERIORE <b>(SMR)</b>	FRONT WHEEL <b>(SMR)</b>	ROUE AVANT <b>(SMR)</b>	VORTERRAD <b>(SMR)</b>	RUEDA DELANTERA <b>(SMR)</b>	143
31	RUOTA POSTERIORE	REAR WHELL	ROUE ARRIERE	HINTERRAD	RUEDA TRASERA	144
32	STRUMENTO DIGITALE, INDICATORI AVVISATORE ACUSTICO <b>(TE-SMR)</b>	DIGITAL INSTRUMENT, BLINKERS, HORN <b>(TE-SMR)</b>	INSTRUMENT DIGITAL, CLIGNOTANTS, SIGNALATEUR ACOUSTIQUE <b>(TE-SMR)</b>	DIGITAL TACHOMETER, BLINKERS, HUPE <b>(TE-SMR)</b>	INSTRUMENTO DIGITAL, INTERMITENTES AVISADOR ACUSTICO <b>(TE-SMR)</b>	151
33	GRUPPO CAVI, PARTI ELETTRICHE <b>(TC, TXC, TE-USA)</b>	MAIN WIRING HARNESS, ELECTRICAL PARTS <b>(TC, TXC, TE-USA)</b>	CABLES PRINCIPAL, PARTIES ELECTRIQUES <b>(TC, TXC, TE-USA)</b>	KABEL, ELEKTRISCHE KOMPONENTE <b>(TC, TXC, TE-USA)</b>	GRUPO PRINCIPAL CABLES, PARTES ELECTRICAS <b>(TC, TXC, TE-USA)</b>	155
33A	GRUPPO CAVI, PARTI ELETTRICHE, FANALI <b>(TE-SMR)</b>	MAIN WIRING HARNESS, LIGHTS, ELECTRICAL PARTS <b>(TE-SMR)</b>	CABLES PRINCIPAL, FEU PARTIES ELECTRIQUES <b>(TE-SMR)</b>	KABEL, LAMPEN, ELEKTRISCHE KOMPONENTE <b>(TE-SMR)</b>	GRUPO PRINCIPAL CABLES, FANALES, PARTES ELECTRICAS <b>(TE-SMR)</b>	157
34	DECALCOMANIE <b>(TE)</b> (codice colore <b>G</b> )	TRANSFER <b>(TE)</b> (color code <b>G</b> )	DECALCOMANIE <b>(TE)</b> (code couleur <b>G</b> )	ABZIEHBILD <b>(TE)</b> (Code Farbe <b>G</b> )	CALCOMANIA <b>(TE)</b> (còdigo colòr <b>G</b> )	161
35	DECALCOMANIE <b>(TC, TXC)</b> (codice colore <b>G</b> )	TRANSFER <b>(TC, TXC)</b> (color code <b>G</b> )	DECALCOMANIE <b>(TC, TXC)</b> (code couleur <b>G</b> )	ABZIEHBILD <b>(TC, TXC)</b> (Code Farbe <b>G</b> )	CALCOMANIA <b>(TC, TXC)</b> (còdigo colòr <b>G</b> )	163
36	DECALCOMANIE <b>(SMR)</b> (codice colore <b>G</b> )	TRANSFER <b>(SMR)</b> (color code <b>G</b> )	DECALCOMANIE <b>(SMR)</b> (code couleur <b>G</b> )	ABZIEHBILD <b>(SMR)</b> (Code Farbe <b>G</b> )	CALCOMANIA <b>(SMR)</b> (còdigo colòr <b>G</b> )	165
37	CANISTER <b>(TE-SMR / USA)</b>	CANISTER <b>(TE-SMR / USA)</b>	CANISTER <b>(TE-SMR / USA)</b>	CANISTER <b>(TE-SMR / USA)</b>	CANISTER <b>(TE-SMR / USA)</b>	167



**Tavola - Drawing - Table - Bild - Tabla**

**1**

**Pagina - Page - Page - Seite - Paja**

**14**

**Tavola - Drawing - Table - Bild - Tabla**

**3**

**Pagina - Page - Page - Seite - Paja**

**20**

**Tavola - Drawing - Table - Bild - Tabla**

**4**

**Pagina - Page - Page - Seite - Paja**

**26**

**Tavola - Drawing - Table - Bild - Tabla**

**5**

**Pagina - Page - Page - Seite - Paja**

**34**

**Tavola - Drawing - Table - Bild - Tabla**

**6**

**Pagina - Page - Page - Seite - Paja**

**36**

Tavola - Drawing - Table - Bild - Tabla

7

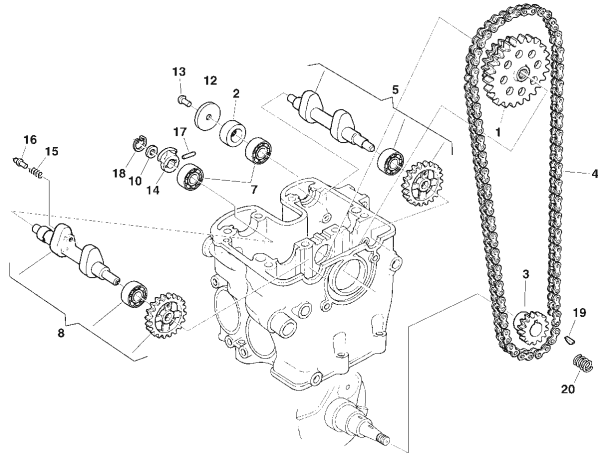

Pagina - Page - Page - Seite - Paja

40

Tavola - Drawing - Table - Bild - Tabla

8

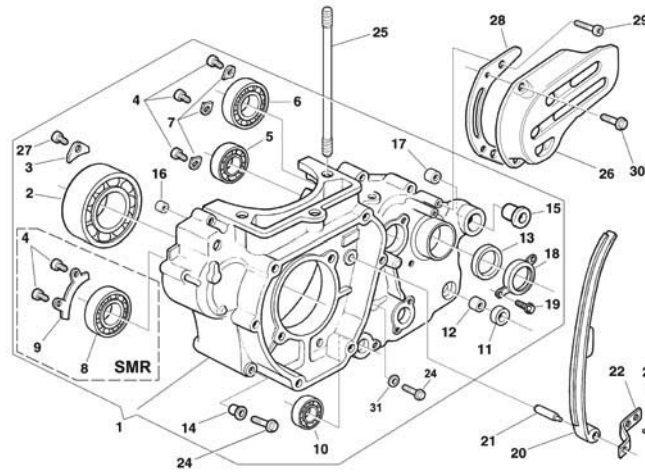

Pagina - Page - Page - Seite - Paja

44

Tavola - Drawing - Table - Bild - Tabla

9

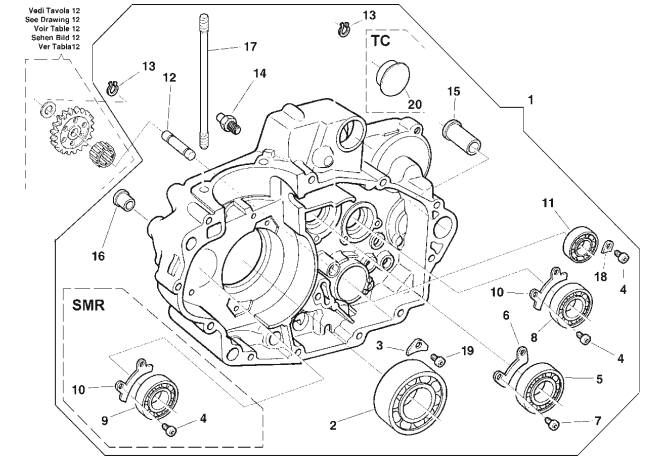

Pagina - Page - Page - Seite - Paja

48

Tavola - Drawing - Table - Bild - Tabla

10

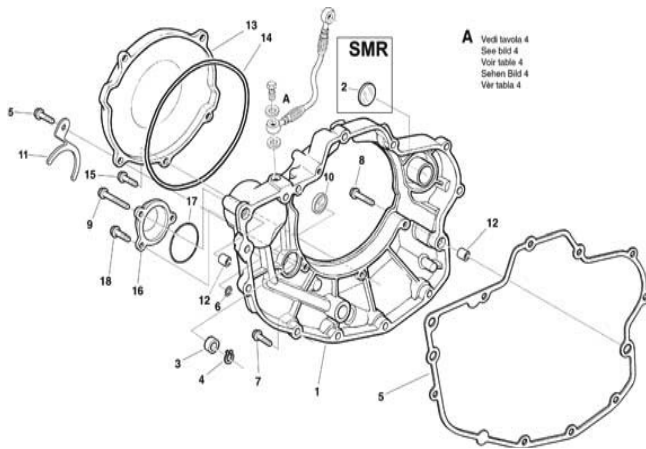

Pagina - Page - Page - Seite - Paja

52

Tavola - Drawing - Table - Bild - Tabla

11

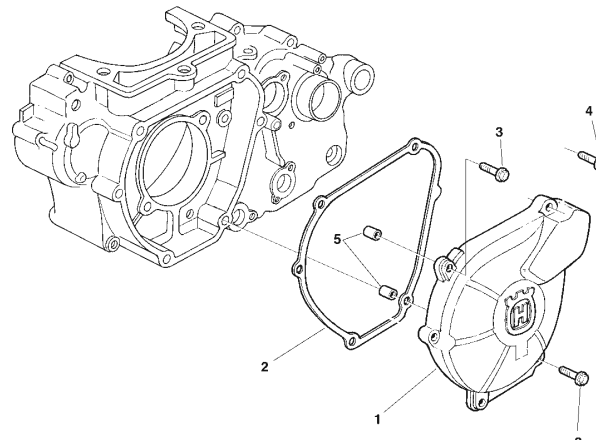

Pagina - Page - Page - Seite - Paja

54

Tavola - Drawing - Table - Bild - Tabla

12

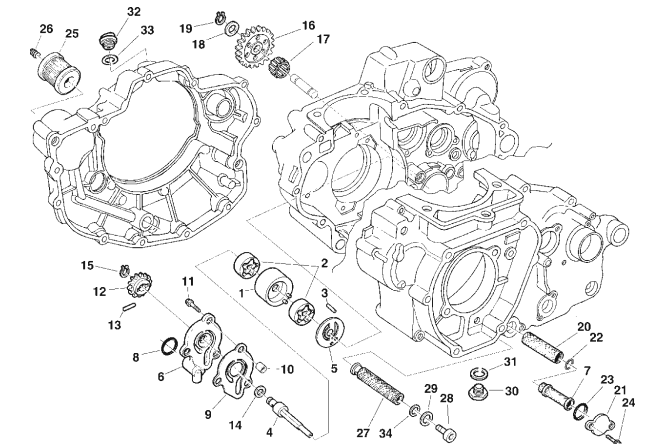

Pagina - Page - Page - Seite - Paja

56

**Tavola - Drawing - Table - Bild - Tabla**

**13**

**Pagina - Page - Page - Seite - Paja**

**60**

**Tavola - Drawing - Table - Bild - Tabla**

**13A**

**Pagina - Page - Page - Seite - Paja**

**64**

**Tavola - Drawing - Table - Bild - Tabla**

**14**

**Pagina - Page - Page - Seite - Paja**

**66**

**Tavola - Drawing - Table - Bild - Tabla**

**15**

**Pagina - Page - Page - Seite - Paja**

**70**

**Tavola - Drawing - Table - Bild - Tabla**

**16**

**Pagina - Page - Page - Seite - Paja**

**74**

**Tavola - Drawing - Table - Bild - Tabla**

**16A**

**Pagina - Page - Page - Seite - Paja**

**80**

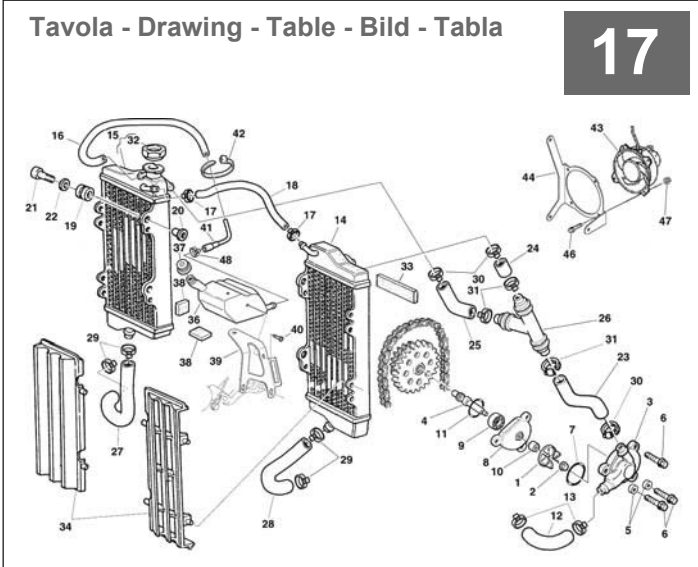

Pagina - Page - Page - Seite - Paja

86

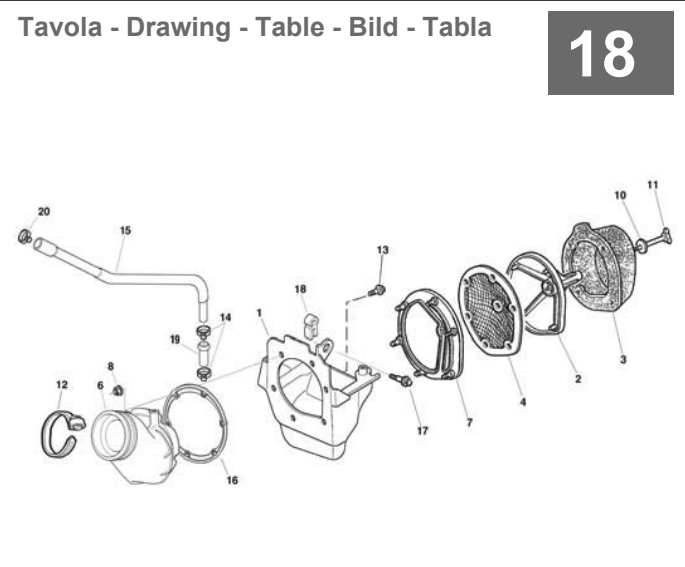

Pagina - Page - Page - Seite - Paja

90

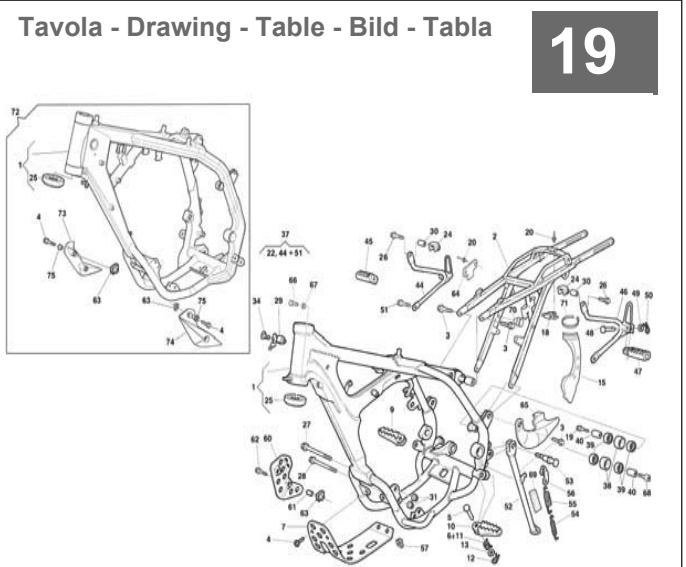

Pagina - Page - Page - Seite - Paja

92

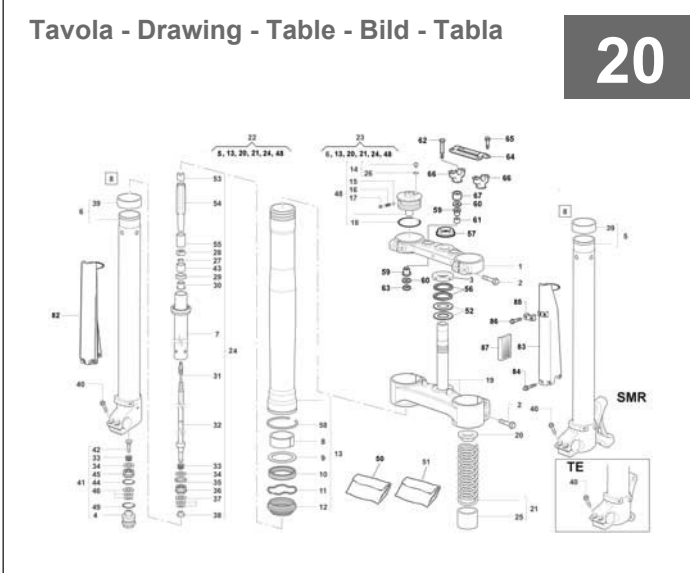

Pagina - Page - Page - Seite - Paja

96

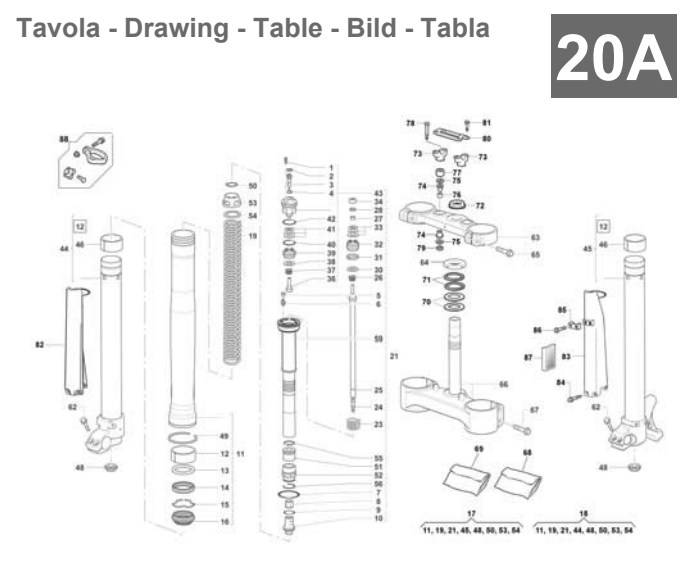

Pagina - Page - Page - Seite - Paja

102

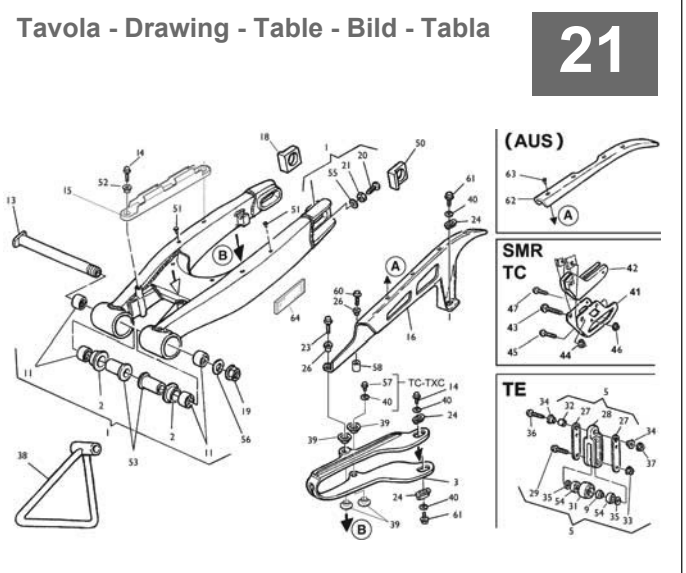

Pagina - Page - Page - Seite - Paja

108

Tavola - Drawing - Table - Bild - Tabla

22

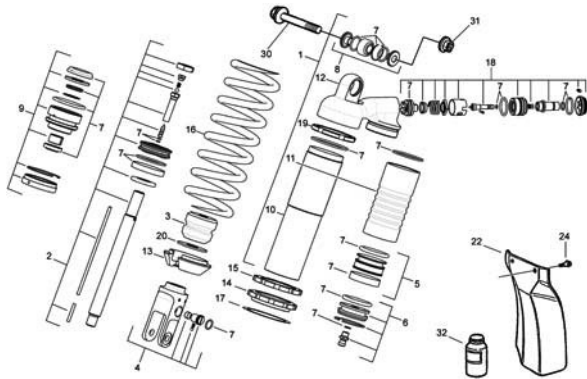

Pagina - Page - Page - Seite - Paja

112

Tavola - Drawing - Table - Bild - Tabla

23

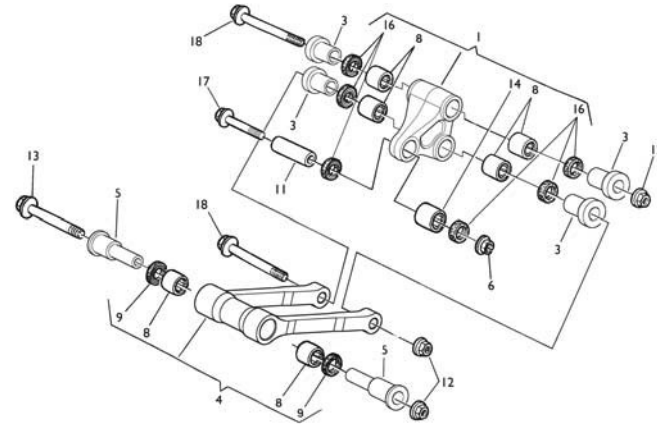

Pagina - Page - Page - Seite - Paja

116

Tavola - Drawing - Table - Bild - Tabla

24

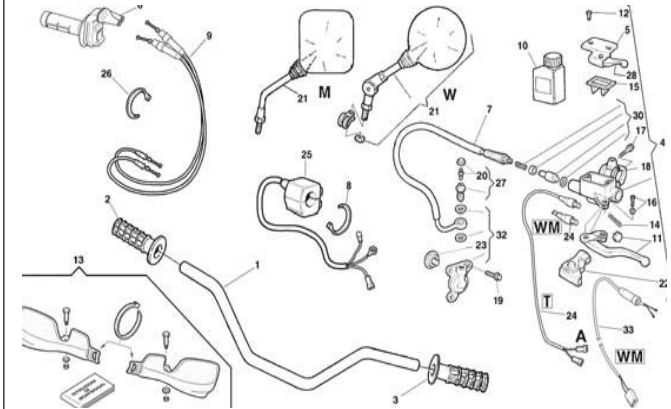

Pagina - Page - Page - Seite - Paja

118

Tavola - Drawing - Table - Bild - Tabla

25

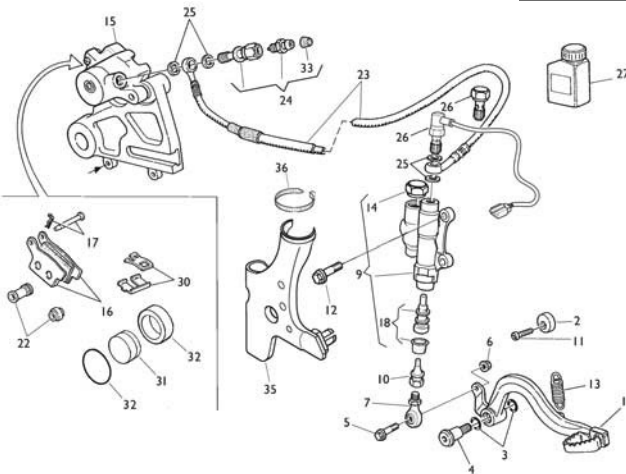

Pagina - Page - Page - Seite - Paja

122

Tavola - Drawing - Table - Bild - Tabla

26

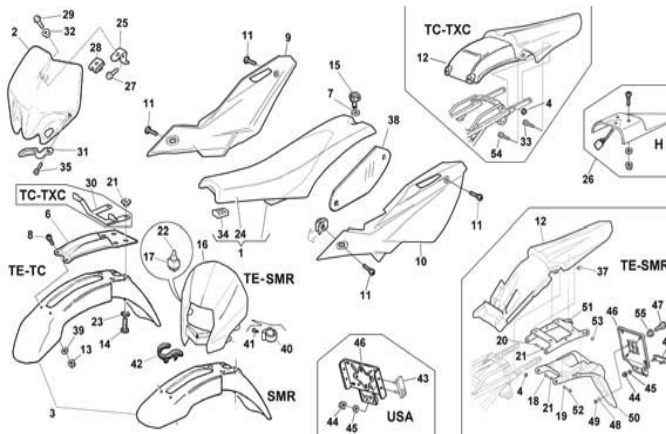

Pagina - Page - Page - Seite - Paja

124

Tavola - Drawing - Table - Bild - Tabla

27

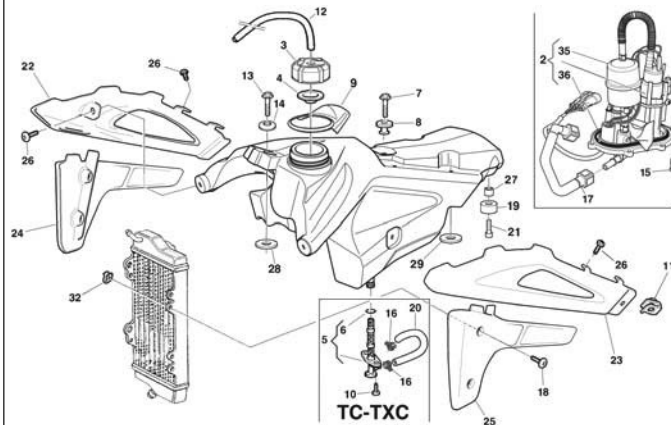

Pagina - Page - Page - Seite - Paja

128

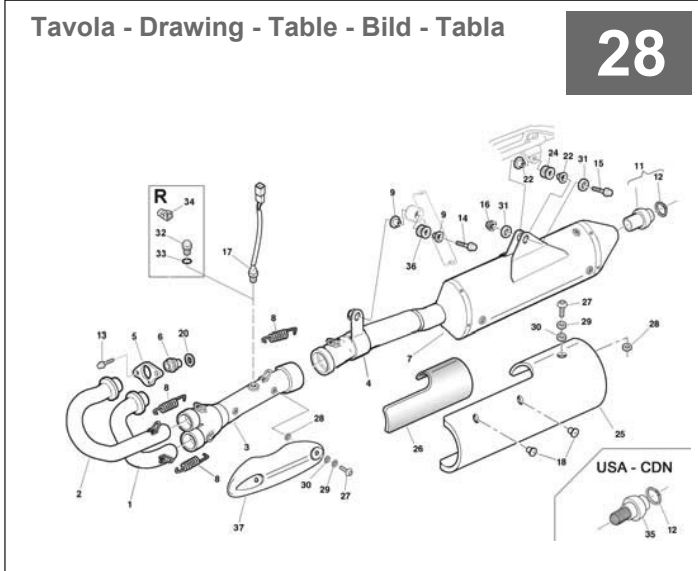

**28**

Pagina - Page - Page - Seite - Paja **132**

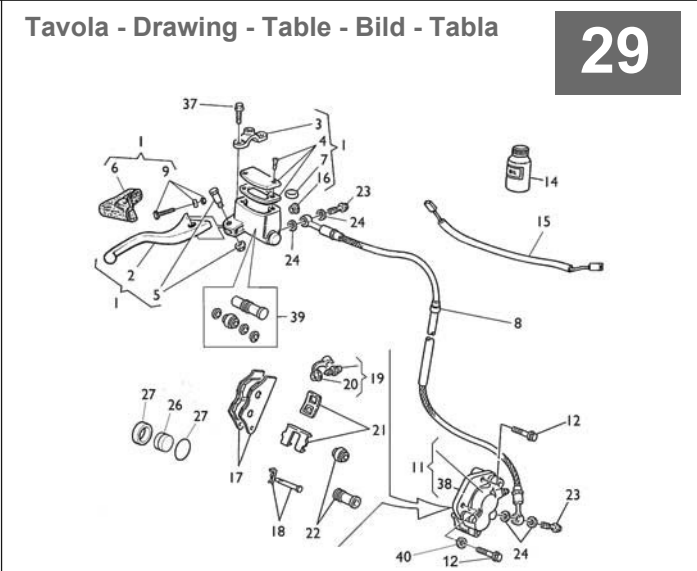

**29**

Pagina - Page - Page - Seite - Paja **136**

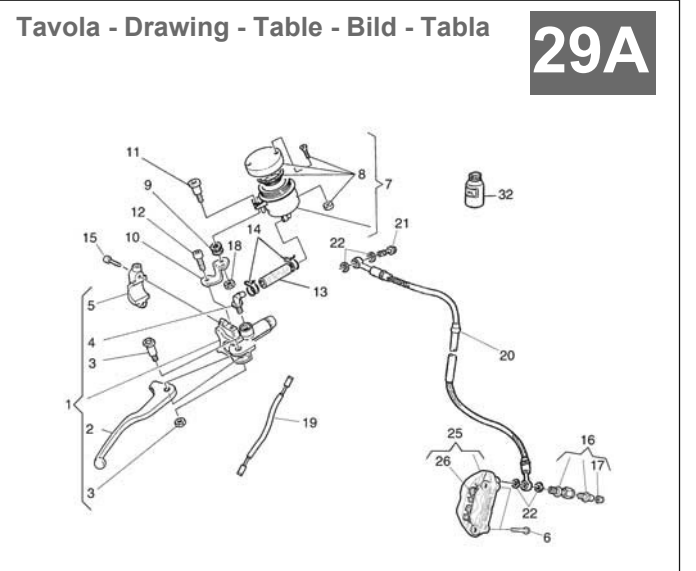

**29A**

Pagina - Page - Page - Seite - Paja **138**

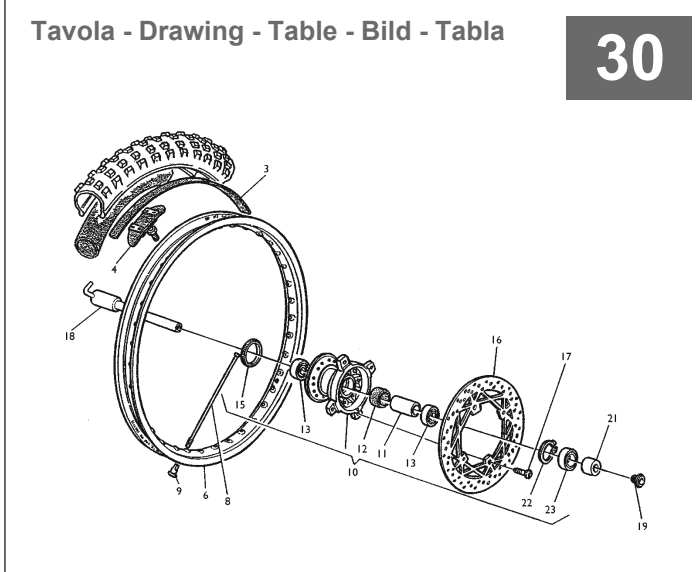

**30**

Pagina - Page - Page - Seite - Paja **140**

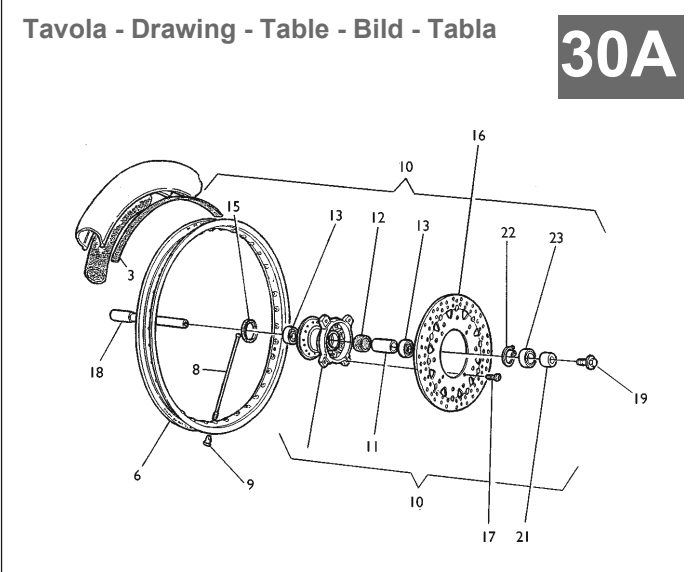

**30A**

Pagina - Page - Page - Seite - Paja **142**

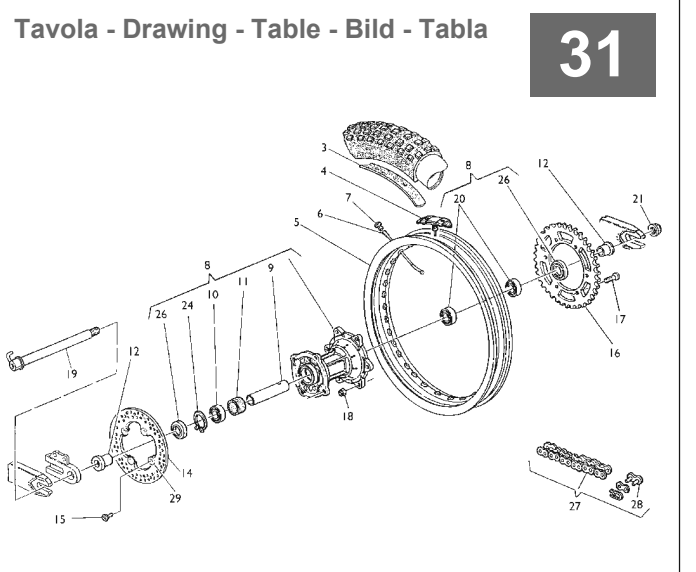

**31**

Pagina - Page - Page - Seite - Paja **144**

Tavola - Drawing - Table - Bild - Tabla

32

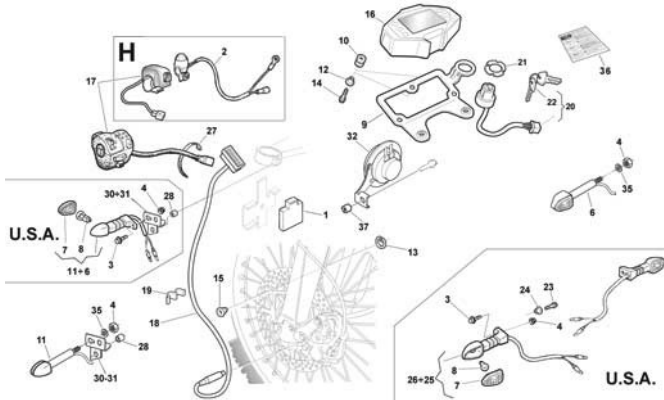

Pagina - Page - Page - Seite - Paja

150

Tavola - Drawing - Table - Bild - Tabla

33

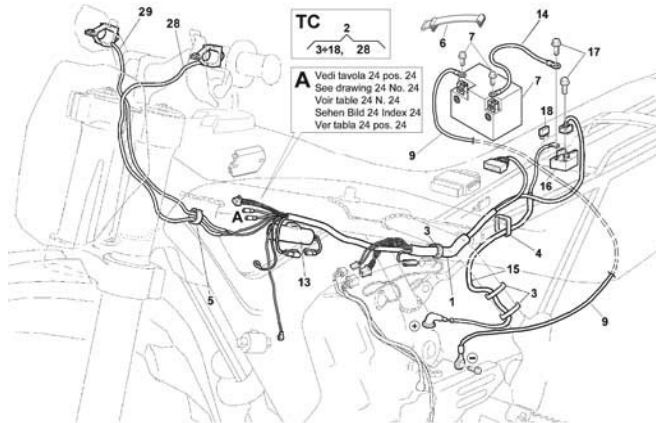

Pagina - Page - Page - Seite - Paja

154

Tavola - Drawing - Table - Bild - Tabla

33A

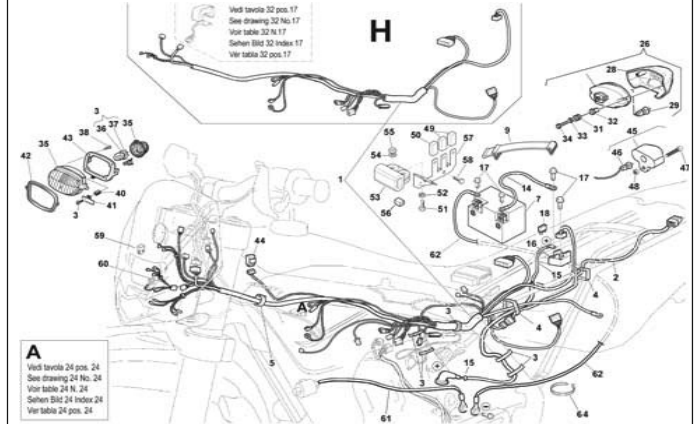

Pagina - Page - Page - Seite - Paja

156

Tavola - Drawing - Table - Bild - Tabla

34



Pagina - Page - Page - Seite - Paja

160

Tavola - Drawing - Table - Bild - Tabla

35



Pagina - Page - Page - Seite - Paja

162

Tavola - Drawing - Table - Bild - Tabla

36



Pagina - Page - Page - Seite - Paja

164

Tavola - Drawing - Table - Bild - Tabla

37

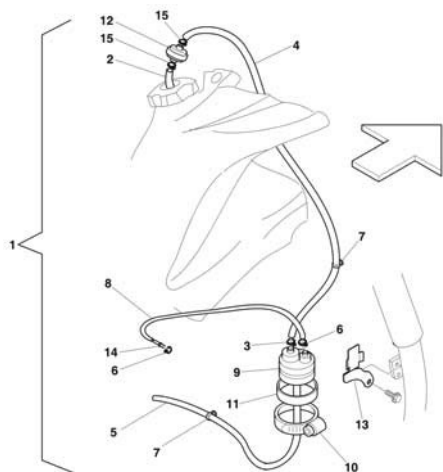

Pagina - Page - Page - Seite - Paja

166





---

**PAGINA INTENZIONALMENTE BIANCA**  
**INTENTIONALLY WHITE PAGE**

---

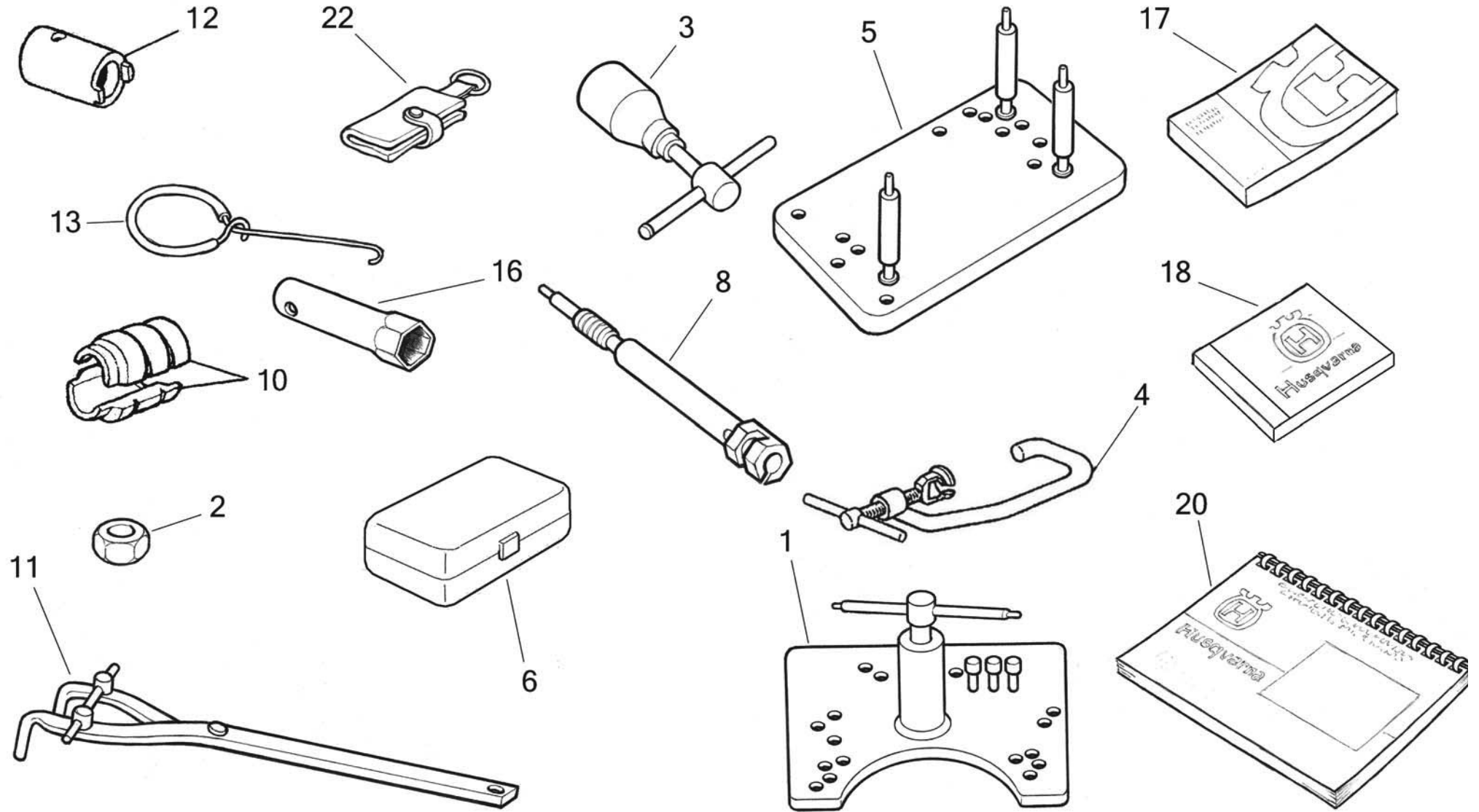

Note Notes Notes Marke Notas	Pos. No. N. Index Pos.	N. Cod. Code No. Nr. Code Code Nr N. Cod.	Q.tà Q.ty Q.te M.ge C.ad	DENOMINAZIONE	NAME	DESIGNATION	BESHREIBUNG	DENOMINACION
	1	151794702	1	ESTRATTORE CARTER MOTORE	PULLER, CRANKCASE	EXTRACTEUR CARTER MOTEUR	AUSZIEHER, KURBELGEHAUSE	EXTRACTOR CARTER MOTOR
	2	8000A1580	1	PROTEZIONE ALBERO MOTORE	GUARD, CRANKSHAFT	PROTECTION VILEBREQUIN	SCHUTZ, KURBELWELLE	PROTECCION CIGUENAL
TC-TXC	3	8000A1559	1	ESTRATTORE VOLANO	FLYWHEEL PULLER	EXTRACTEUR VOLANT MAGNETIQUE	AUSZIEHER, SCHWUNGRAD	EXTRACTOR VOLANTE
TE-SMR	3	8000B0144	1	ESTRATTORE VOLANO	FLYWHEEL PULLER	EXTRACTEUR VOLANT MAGNETIQUE	AUSZIEHER, SCHWUNGRAD	EXTRACTOR VOLANTE
	4	800039521	1	ATTREZZO MONTAGGIO E SMONTAGGIO VALVOLE	TOOL, VALVES MOUNTING	OUTIL MONTAGE SOUPAPES	WERKZEUG FUER VENTILMONTAGE	HERRAMIENTA MONTAJE VALVULAS
	5	8A0090662	1	SUPPORTO PER MONTAGGIO MOTORE	SUPPORT ASSY	SUPPORT COMPL.	HALTER	SOPORTE
TE-SMR	6	8000A9634	1	SOFTWARE DIAGNOSTICA	DIAGNOSTIC SOFTWARE	LOGICIEL DIAGNOSTIC	DIAGNOSE SOFTWARE	SOFTWARE DIAGNOSTICA
	8	8000A1625	1	ATTREZZO PORTACOMPARATORE	DIAL GAUGE HOLDING TOOL	OUTIL SUPPORT COMPARETEUR	WERKZEUG MESSUHRHALTER	HERRAMIENTA PORTA RELOJ COMPARADOR
	10	800091288	1	INTRODOTTORE MESSA IN MOTO	JAW	MACHOIRE	ZUSATZBACKE	TENAZA
	11	800079015	1	ATTREZZO BLOCCAGGIO FRIZIONE	WRENCH, CLUTCH HUB RETAINING	OUTIL VERROULAGE EMBRAYAGE	SCHLUSSEL KUPPLUNGSNABE	HERRAMIENTA MONTAJE EMBRAGUE
	12	800091289	1	ATTREZZO BLOCCA CARTUCCIA	PUMPING RETAINER	ARRET POMPAGE	KLAMMER PUMPEN	BROCHE BOMBEADORE
	13	151984701	1	GANCIO MONTAMOLLE	SPRING HOOK	CROCHET RESSORT	FEDERHAKEN	GANCHO RESORTE
	16	800095749	1	CHIAVE CANDELA	WRENCH, SPARK PLUG	CLE A BOUGIE	ZUENDKERZENSCHLUESSEL	LLAVE, BUJIA
	17	8000B0147	1	MANUALE UTENTE	OWNER'S MANUAL	MANUEL D'UTILISATION ET ENTRETIEN	ANLEITUNGS UND WARTUNGSHEFT	MANUAL USO Y ENTRETENIMIENTO
	18	8000B0148	1	MANUALE OFFICINA	WORKSHOP MANUAL	MANUEL D'ATELIER	WERKSTATTHANDBUCH	MANUAL DE TALLER
	20	8000B0149	1	CATALOGO RICAMBI	SPARE PARTS CATALOGUE	CATALOGUE PIECES DE RECHANGE	ERSATZTEILKATALOG	CATALOGO PIEZAS DE REPUESTO
TE-SMR	22	800097615	1	PORTACHIAVI	KEYRING	PORTECLEFS	SCHLUESSELRING	LLAVERO

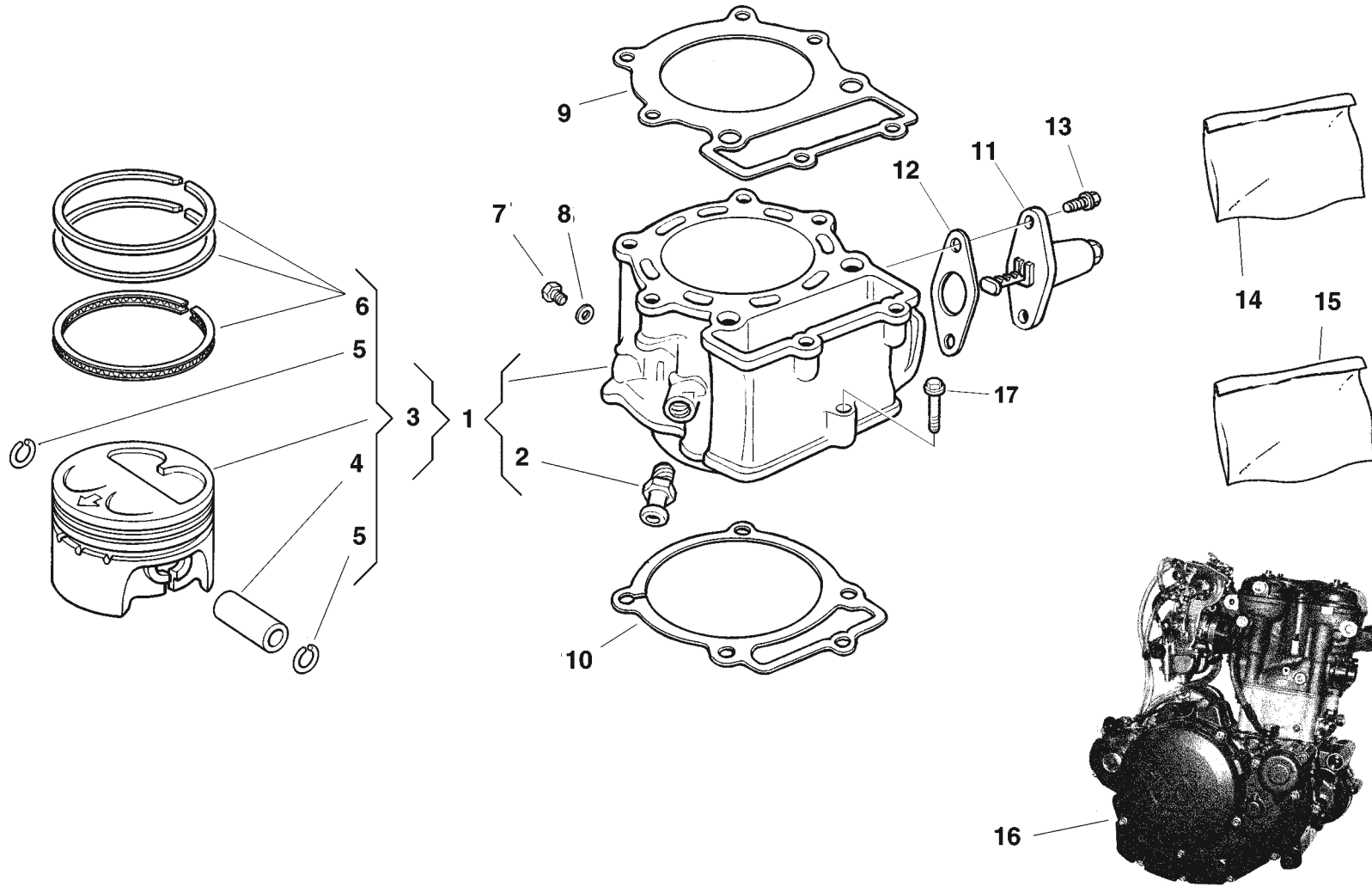

Note Notes Notes Marke Notas	Pos. No. N. Index Pos.	N. Cod. Code No. Nr. Code Code Nr N. Cod.	Q.tà Q.ty Q.te M.ge C.ad	DENOMINAZIONE	NAME	DESIGNATION	BESHREIBUNG	DENOMINACION
250	1	8000A5456	1	CILINDRO COMPLETO	CYLINDER ASSY	CYLINDRE COMPLET	ZYLINDER KOMPL	CILINDRO COMPLETO
SMR-TE 450	1	8000A9654	1	CILINDRO COMPLETO	CYLINDER ASSY	CYLINDRE COMPLET	ZYLINDER KOMPL	CILINDRO COMPLETO
SMR-TE 450	1	8000A6050	1	CILINDRO COMPLETO	CYLINDER ASSY	CYLINDRE COMPLET	ZYLINDER KOMPL	CILINDRO COMPLETO
TC-TXC 450	1	8000A5470	1	CILINDRO COMPLETO	CYLINDER ASSY	CYLINDRE COMPLET	ZYLINDER KOMPL	CILINDRO COMPLETO
TC-TXC 510	1	8000A5483	1	CILINDRO COMPLETO	CYLINDER ASSY	CYLINDRE COMPLET	ZYLINDER KOMPL	CILINDRO COMPLETO
TE-SMR 510	1	8000B0645	1	CILINDRO COMPLETO	CYLINDER ASSY	CYLINDRE COMPLET	ZYLINDER KOMPL	CILINDRO COMPLETO
TE-SMR 510	1	8000A9919	1	CILINDRO COMPLETO	CYLINDER ASSY	CYLINDRE COMPLET	ZYLINDER KOMPL	CILINDRO COMPLETO
	2	800063885	2	RACCORDO	JOINT	RACCORD	ANSCHLUSS	EMPALME
250	3	8000A6110	1	PISTONE COMPLETO 76 MM	PISTON ASSY. 76 MM	PISTON COMPLET 76 MM	KOLBEN KOMPLETT 76 MM	PISTON COMPLETO 76 MM
TC-TXC 450	3	8000A5471	1	PISTONE COMPLETO 97 MM	PISTON ASSY. 97 MM	PISTON COMPLET 97 MM	KOLBEN KOMPLETT 97 MM	PISTON COMPLETO 97 MM
TC-TXC 510	3	8000A5484	1	PISTONE COMPLETO 97 MM	PISTON ASSY. 97 MM	PISTON COMPLET 97 MM	KOLBEN KOMPLETT 97 MM	PISTON COMPLETO 97 MM
TE-SMR 450	3	8000A6052	1	PISTONE COMPLETO 97 MM	PISTON ASSY. 97 MM	PISTON COMPLET 97 MM	KOLBEN KOMPLETT 97 MM	PISTON COMPLETO 97 MM
TE-SMR 450	3	8000A9650	1	PISTONE COMPLETO 97 MM	PISTON ASSY. 97 MM	PISTON COMPLET 97 MM	KOLBEN KOMPLETT 97 MM	PISTON COMPLETO 97 MM
TE-SMR 510	3	8000A9228	1	PISTONE COMPLETO 97 MM	PISTON ASSY. 97 MM	PISTON COMPLET 97 MM	KOLBEN KOMPLETT 97 MM	PISTON COMPLETO 97 MM
TE-SMR 510	3	8000A9920	1	PISTONE COMPLETO 97 MM	PISTON ASSY. 97 MM	PISTON COMPLET 97 MM	KOLBEN KOMPLETT 97 MM	PISTON COMPLETO 97 MM
250	4	8000A5459	1	SPINOTTO PISTONE	PIN, PISTON	AXE PISTON	KOLBENBOLZEN	BULON PISTON
TC-TXC 450-510	4	8000A5474	1	SPINOTTO PISTONE	PIN, PISTON	AXE PISTON	KOLBENBOLZEN	BULON PISTON
TE-SMR 450-510	4	8000A9652	1	SPINOTTO PISTONE	PIN, PISTON	AXE PISTON	KOLBENBOLZEN	BULON PISTON
TE-SMR 450-510	4	8000A0854	1	SPINOTTO PISTONE	PIN, PISTON	AXE PISTON	KOLBENBOLZEN	BULON PISTON
250	5	8000A5460	2	ANELLINO FERMA SPINOTTO	CLIP PISTON PIN	ATTACHE AXE PISTON	SICHERUNG, KOLBENBOLZEN	GRAPA, BULON PISTON
TC-TXC-TE-SMR 450-510	5	8000A5475	2	ANELLINO FERMA SPINOTTO	CLIP PISTON PIN	ATTACHE AXE PISTON	SICHERUNG, KOLBENBOLZEN	GRAPA, BULON PISTON
TE-SMR 450-510	5	8000A3378	2	ANELLINO FERMA SPINOTTO	CLIP PISTON PIN	ATTACHE AXE PISTON	SICHERUNG, KOLBENBOLZEN	GRAPA, BULON PISTON
250	6	8000A5923	1	SERIE SEGMENTI	PISTON RING SET	JEU SEGMENT PISTON	KOLBENRING SATZ	JUEGO ARO PISTON
TC-TXC 450-510	6	8000A5476	1	SERIE SEGMENTI	PISTON RING SET	JEU SEGMENT PISTON	KOLBENRING SATZ	JUEGO ARO PISTON
TE-SMR 450	6	8000A0855	1	SERIE SEGMENTI	PISTON RING SET	JEU SEGMENT PISTON	KOLBENRING SATZ	JUEGO ARO PISTON
TE-SMR 450-510	6	8000A0009	1	SERIE SEGMENTI	PISTON RING SET	JEU SEGMENT PISTON	KOLBENRING SATZ	JUEGO ARO PISTON
	7	8S0067545	1	VITE TEF M6X1X8 CH8	SCREW TEF M6X1X8 CH8	VIS TEF M6X1X8 CH8	SCHRAUBE TEF M6X1X8 CH8	TORNILLO TEF M6X1X8 CH8
	8	8A0015960	1	GUARNIZIONE 10X6,2X1	GASKET 10X6,2X1	JOINT 10X6,2X1	DICHTUNG 10X6,2X1	JUNTA 10X6,2X1

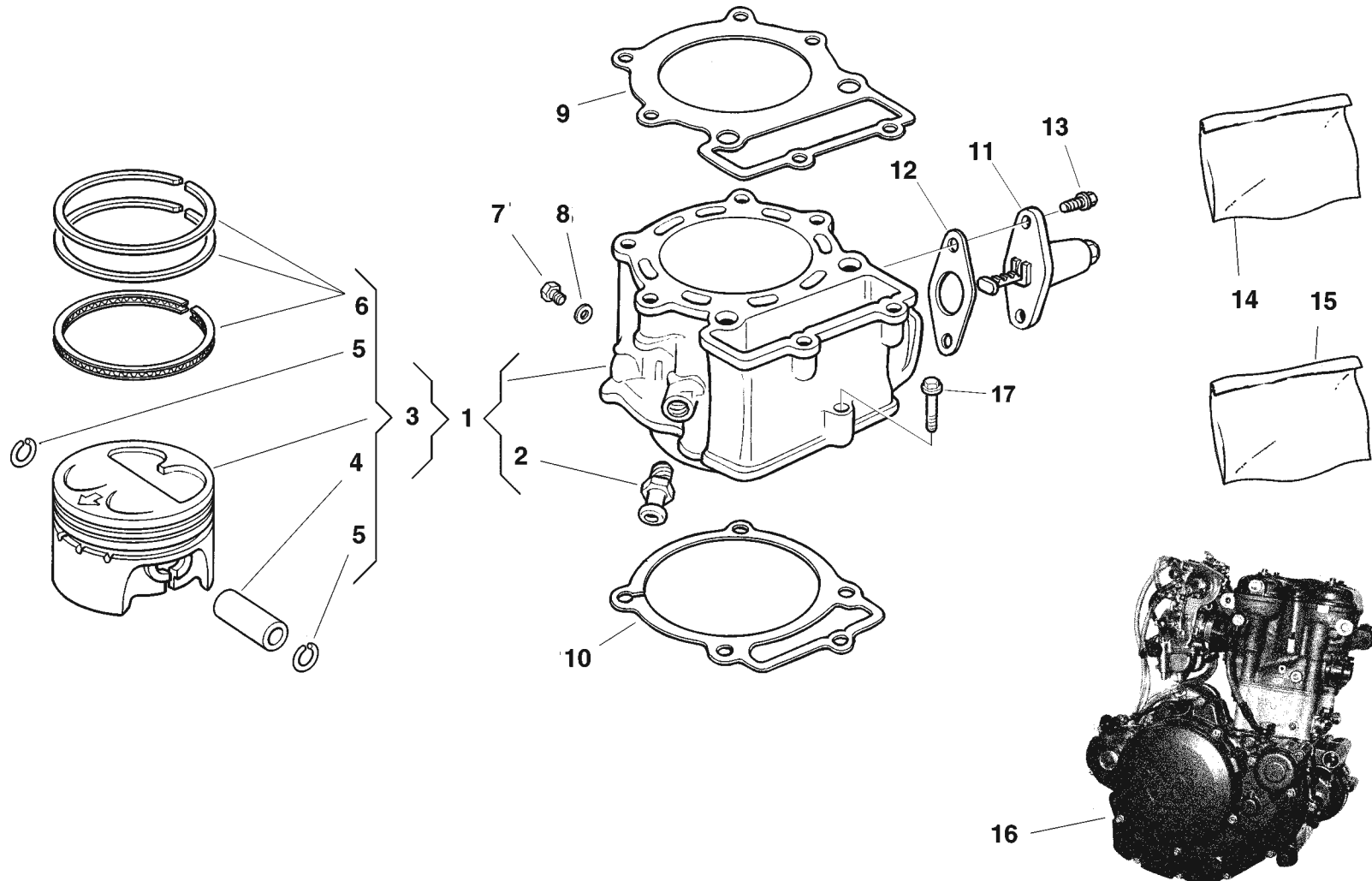

Note Notes Notes Marke Notas	Pos. No. Index Pos.	N. Cod. Code No. Nr. Code Code Nr N. Cod.	Q.tà Q.ty Q.te M.ge C.ad	DENOMINAZIONE	NAME	DESIGNATION	BESHREIBUNG	DENOMINACION
250	9	8000A5462	1	GUARNIZIONE TESTA CILINDRO 0,8 MM	GASKET CYLINDER HEAD 0.8 MM	JOINT CULASSE 0,8 MM	DICHTUNG ZYLINDERKOPF 0,8 MM	JUNTA CULATA 0,8 MM
250	9	8B00A5462	1	GUARNIZIONE TESTA CILINDRO 0,9 MM	GASKET CYLINDER HEAD 0.9 MM	JOINT CULASSE 0,9 MM	DICHTUNG ZYLINDERKOPF 0,9 MM	JUNTA CULATA 0,9 MM
250	9	8A00A5462	1	GUARNIZIONE TESTA CILINDRO 0,7 MM	GASKET CYLINDER HEAD 0.7 MM	JOINT CULASSE 0,7 MM	DICHTUNG ZYLINDERKOPF 0,7 MM	JUNTA CULATA 0,7 MM
450-510	9	8E00A4195	1	GUARNIZIONE TESTA CILINDRO 1,0 MM	GASKET CYLINDER HEAD 1.0 MM	JOINT CULASSE 1,0 MM	DICHTUNG ZYLINDERKOPF 1,0 MM	JUNTA CULATA 1,0 MM
450-510	9	8H00A4195	1	GUARNIZIONE TESTA CILINDRO 1,2 MM	GASKET CYLINDER HEAD 1.2 MM	JOINT CULASSE 1,2 MM	DICHTUNG ZYLINDERKOPF 1,2 MM	JUNTA CULATA 1,2 MM
450-510	9	8B00A4195	1	GUARNIZIONE TESTA CILINDRO 1,1 MM	GASKET CYLINDER HEAD 1.1 MM	JOINT CULASSE 1,1 MM	DICHTUNG ZYLINDERKOPF 1,1 MM	JUNTA CULATA 1,1 MM
	10	800099841	1	GUARNIZIONE BASE CILINDRO	GASKET, CYLNDER BASE	JOINT BASE CYLINDRE	DICHTUNG, ZYLINDER	JUNTA BASE CILINDRO
	11	800067744	1	TENDICATENA DISTRIBUZIONE	TENSIONER, TIMING CHAIN	TENDEUR CHAINE DISTRIBUTION	STEUERKETTENSANNER	TENSIONADOR CADENA DISTRIBUCION
	12	161535801	1	GUARNIZIONE TENDICATENA DISTRIBUZIONE	GASKET, TENSIONER ADJUSTER	JOINT TENDEUR CHAINE DISTRIBUTION	DICHTUNG STEUERKETTENSANNER	JUNTA TENSIONADOR CADENA DISTRIBUCION
	13	800062727	2	VITE TE M6X1X16 CH8	SCREW TE M6X1X16 CH8	VIS TE M6X1X16 CH8	SCHRAUBE TE M6X1X16 CH8	TORNILLO TE M6X1X16 CH8
250	14	8000A5755	1	SERIE GUARNIZIONI MOTORE	GASKET SET, ENGINE	JEU JOINT MOTEUR	MOTORDICHTUNGSSATZ	JUEGO JUNTAS MOTOR
450-510	14	8000A5982	1	SERIE GUARNIZIONI MOTORE	GASKET SET, ENGINE	JEU JOINT MOTEUR	MOTORDICHTUNGSSATZ	JUEGO JUNTAS MOTOR
TC-TXC 250	15	8000A5735	1	SERIE PARAOLIO MOTORE	OIL SEAL SET, ENGINE	JEU BAGUES ETANCHEITE MOTEUR	MOTORWELLENDICHTRINGENSATZ	JUEGO RETENES ACEITE MOTOR
TC-TXC 450-510	15	8000A5736	1	SERIE PARAOLIO MOTORE	OIL SEAL SET, ENGINE	JEU BAGUES ETANCHEITE MOTEUR	MOTORWELLENDICHTRINGENSATZ	JUEGO RETENES ACEITE MOTOR
TE 250	15	8000B0373	1	SERIE PARAOLIO MOTORE	OIL SEAL SET, ENGINE	JEU BAGUES ETANCHEITE MOTEUR	MOTORWELLENDICHTRINGENSATZ	JUEGO RETENES ACEITE MOTOR
TE-SMR 450-510	15	8000B0364	1	SERIE PARAOLIO MOTORE	OIL SEAL SET, ENGINE	JEU BAGUES ETANCHEITE MOTEUR	MOTORWELLENDICHTRINGENSATZ	JUEGO RETENES ACEITE MOTOR

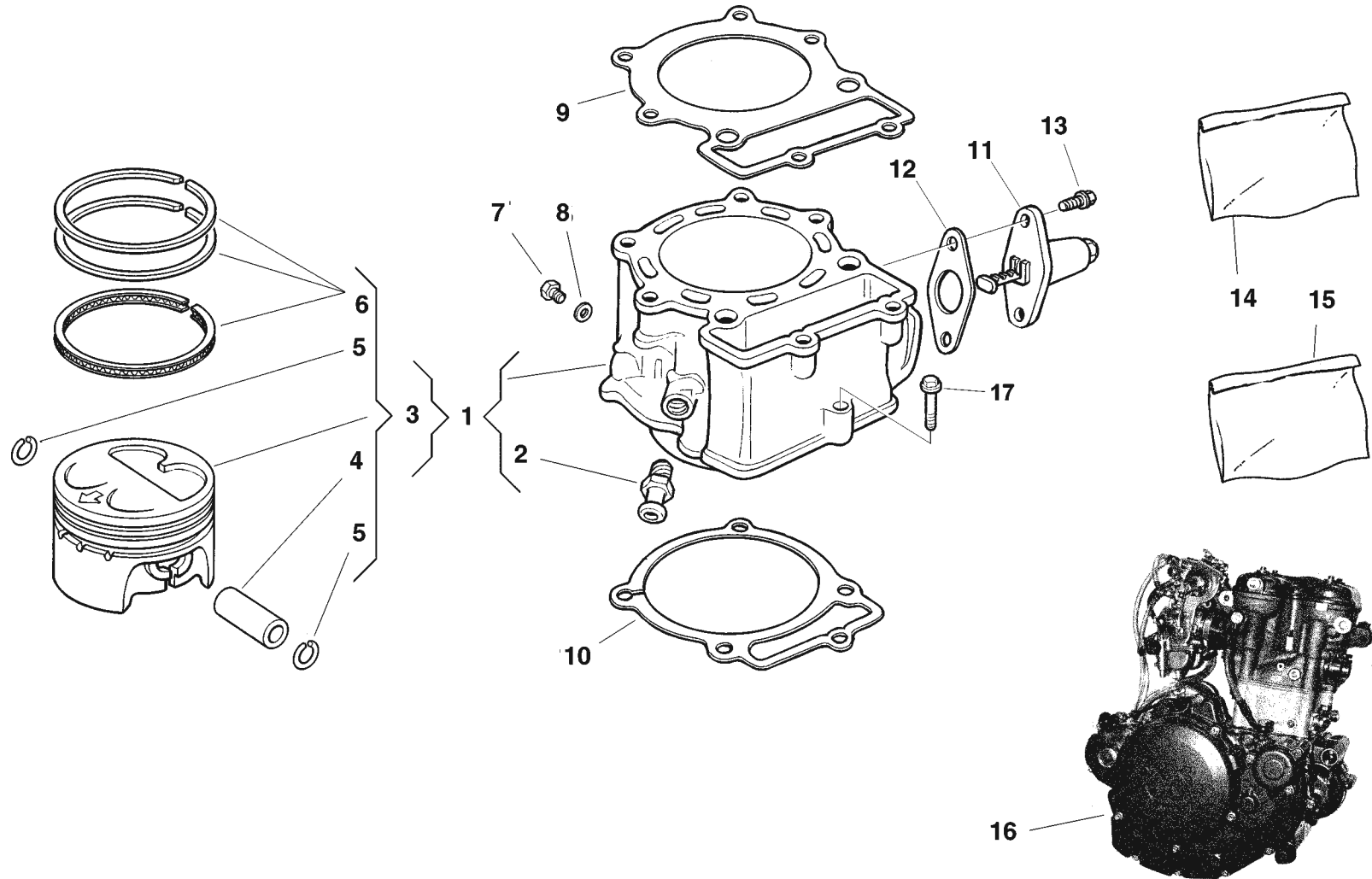





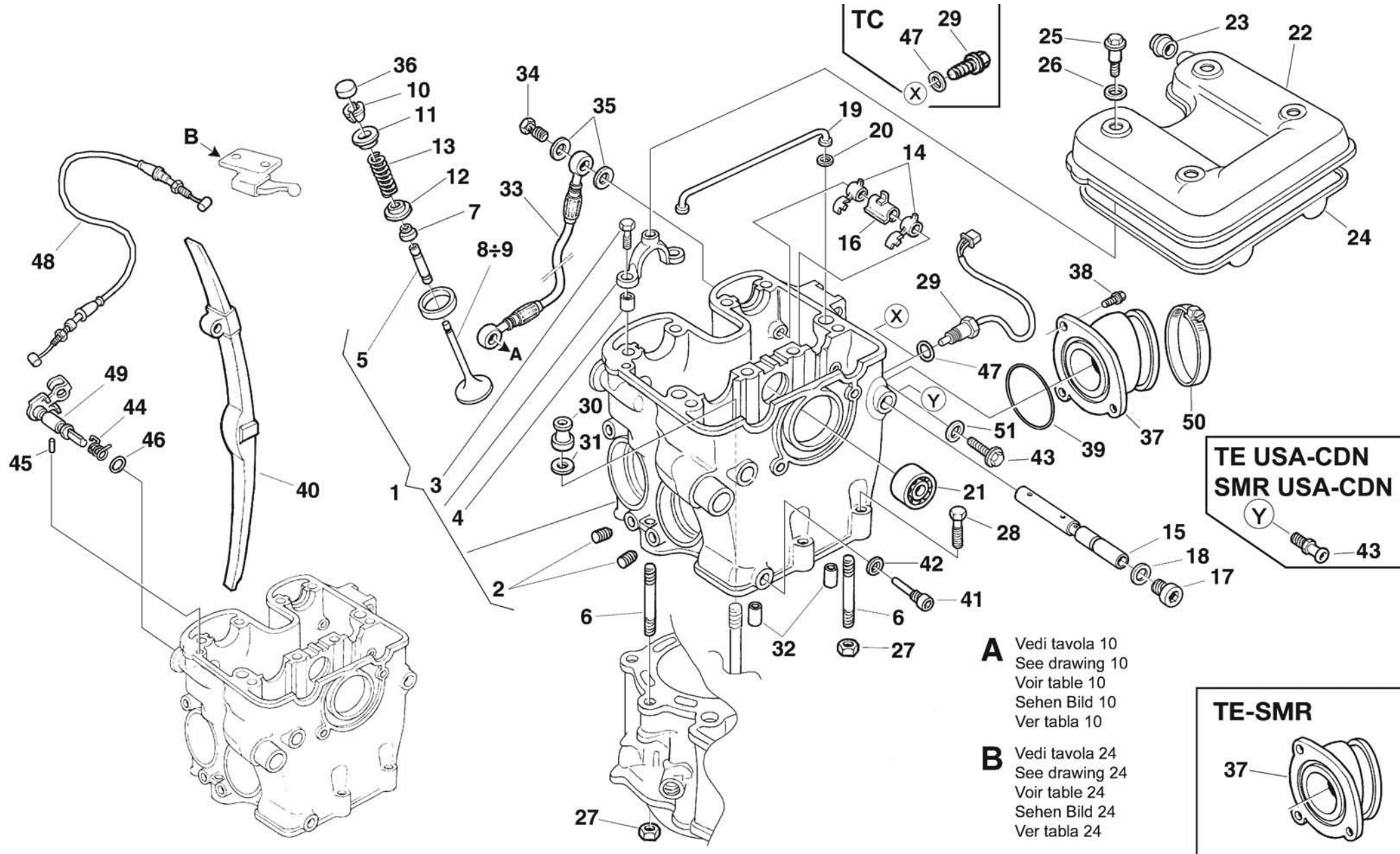

**A** Vedi tavola 10  
See drawing 10  
Voir table 10  
Sehen Bild 10  
Ver tabla 10

**B** Vedi tavola 24  
See drawing 24  
Voir table 24  
Sehen Bild 24  
Ver tabla 24

**TE USA-CDN  
SMR USA-CDN**  
Y 43

**TE-SMR**  
37

Note Notes Notes Marke Notas	Pos. No. N. Index Pos.	N. Cod. Code No. Nr. Code Code Nr N. Cod.	Q.tà Q.ty Q.te M.ge C.ad	DENOMINAZIONE	NAME	DESIGNATION	BESHREIBUNG	DENOMINACION
250	1	8000B0394	1	TESTA CILINDRO	HEAD, CYLINDER	CULASSE	ZYLINDERKOPF	CULATA
450-510	1	8000B0407	1	TESTA CILINDRO	HEAD, CYLINDER	CULASSE	ZYLINDERKOPF	CULATA
	2	800049792	4	INSERTO FILETTATO HELI-COIL	THREADED INSERT HELI-COIL	INSERTION FILETE HELI-COIL	GEWINDINSATZ HELI-COIL	ROSCA ROSCADA HELI-COIL
	3	8A0085071	8	VITE TCEI M6X1X25	SCREW TCEI M6X1X25	VIS TCEI M6X1X25	SCHRAUBE TCEI M6X1X25	TORNILLO TCEI M6X1X25
	4	161795501	8	BUSSOLA 8X6,4X6	BUSH 8X6.4X6	DOUILLE 8X6,4X6	BUCHSE 8X6,4X6	CASQUILLO 8X6,4X6
250	5	8000A4152	4	GUIDAVALVOLA 5 MM	GUIDE-VALVE 5 MM	GUIDE-SOUPAPE 5 MM	VENTILFUEHRUNG 5 MM	GUIA-VALVULA 5 MM
450-510	5	8000A4158	2	GUIDAVALVOLA SCARICO 5 MM	GUIDE, EXHAUST VALVE 5 MM	GUIDE-SOUPAPE ECHAPPEMENT 5 MM	AUSLASSVENTILFUEHRUNG 5 MM	GUIA-VALVULA ESCAPE 5 MM
450-510	5	8000A4159	2	GUIDAVALVOLA ASPIRAZIONE 5,5 MM	GUIDE INTAKE VALVE 5.5 MM	GUIDE-SOUPAPE D'ASPIRATION 5,5 MM	EINLASSVENTILFUEHRUNG 5,5 MM	GUIA-VALVULA ADMISION 5,5 MM
	6	800074836	2	PRIGIONIERO CILINDRO M8X51MM	STUD BOLT M8X51MM	GOUJON M8X51MM	STIFTSCHRAUBE M8X51MM	ESPARRAGO M8X51MM
250	7	8000A4136	4	PARAOLIO VALVOLA 5 MM	SEAL VALVE STEM 5 MM	BAGUE D'ETENCHEITE SOUPAPE 5 MM	WELLENDICHTRING VENTIL 5 MM	RETEN DE ACEITE VALVULA 5 MM
450-510	7	8000A4136	2	PARAOLIO VALVOLA 5 MM	SEAL VALVE STEM 5 MM	BAGUE D'ETENCHEITE SOUPAPE 5 MM	WELLENDICHTRING VENTIL 5 MM	RETEN DE ACEITE VALVULA 5 MM
450-510	7	8000A4137	2	PARAOLIO VALVOLA 5,5 MM	SEAL VALVE STEM 5.5 MM	BAGUE D'ETENCHEITE SOUPAPE 5,5 MM	WELLENDICHTRING VENTIL 5,5 MM	RETEN DE ACEITE VALVULA 5,5 MM
250	8	8000A5439	2	VALVOLA ASPIRAZIONE	VALVE, INTAKE	SOUPAPE ADMISSION	EINLASSVENTIL	VALVULA ADMISION
450-510	8	8000A5444	2	VALVOLA ASPIRAZIONE	VALVE, INTAKE	SOUPAPE ADMISSION	EINLASSVENTIL	VALVULA ADMISION
TE-SMR 250	8	8000A5440	2	VALVOLA ASPIRAZIONE TITANIO 5X30,5 MM	VALVE, INTAKE TITANIUM 5X30.5 MM	SOUPAPE ADMISSION TITANE 5X30,5 MM	VENTIL, EINLASS TITAN 5X30,5 MM	VALVULA ADMISION TITANIO 5X30,5 MM
TE-SMR 450-510	8	8000A5445	2	VALVOLA ASPIRAZIONE TITANIO 5,5X37 MM	VALVE, INTAKE TITANIUM 5.5X37 MM	SOUPAPE ADMISSION TITANE 5,5X37 MM	VENTIL, EINLASS TITAN 5,5X37 MM	VALVULA ADMISION TITANIO 5,5X37 MM
250	9	8000A5438	2	VALVOLA SCARICO	VALVE, EXHAUST	SOUPAPE ECHAPPEMENT	AUSLASSVENTIL	VALVULA ESCAPE
450-510	9	8000A5442	2	VALVOLA SCARICO	VALVE, EXHAUST	SOUPAPE ECHAPPEMENT	AUSLASSVENTIL	VALVULA ESCAPE
TE-SMR 250	9	8000A5441	2	VALVOLA SCARICO TITANIO 5X25 MM	VALVE, EXHAUST TITANIUM 5X25 MM	SOUPAPE D'ECHAPPEMENT TITANE 5X25 MM	VENTIL, AUSLASS TITAN 5X25 MM	VALVULA DE ESCAPE TITANIO 5X25 MM
TE-SMR 450-510	9	8000A5443	2	VALVOLA SCARICO TITANIO 5X31 MM	VALVE, EXHAUST TITANIUM 5X31 MM	SOUPAPE D'ECHAPPEMENT TITANE 5X31 MM	VENTIL, AUSLASS TITAN 5X31 MM	VALVULA DE ESCAPE TITANIO 5X31 MM
250	10	8000A4106	8	SEMICONO VALVOLA 5 MM	COTTER, VALVE 5 MM	DEMI-CLAVETTE SOUPAPE 5 MM	VENTILHALBKEGEL 5 MM	SEMICONO VALVULA 5 MM
450-510	10	8000A4107	4	SEMICONO VALVOLA 5,5 MM	COTTER, VALVE 5.5 MM	DEMI-CLAVETTE SOUPAPE 5,5 MM	VENTILHALBKEGEL 5,5 MM	SEMICONO VALVULA 5,5 MM
450-510	10	8000A4106	4	SEMICONO VALVOLA 5 MM	COTTER, VALVE 5 MM	DEMI-CLAVETTE SOUPAPE 5 MM	VENTILHALBKEGEL 5 MM	SEMICONO VALVULA 5 MM
250	11	8000A4151	4	SCODELLINO MOLLA VALVOLA SCARICO 5 MM	RETAINER, EHAUST VALVE SPRING 5 MM	FIXATION RESSORT SUPAPE ECHAPPEM. 5 MM	TELLER, AUSLASSVENTILFEDER 5 MM	RETEN, RESORTE VALVULA DESCARGA 5 MM
450-510	11	8000A4157	2	SCODELLINO MOLLA VALVOLA ASPIRAZ. 5,5 MM	RETAINER, SPRING INTAKE VALVE 5.5 MM	FIXATION RESSORT SUPAPE ASPIRATION 5,5MM	TELLER, EINLASSVENTILFEDER 5,5 MM	RETEN, RESORTE VALVULA ADMISION 5,5 MM
450-510	11	8000A4151	2	SCODELLINO MOLLA VALVOLA SCARICO 5 MM	RETAINER, EHAUST VALVE SPRING 5 MM	FIXATION RESSORT SUPAPE ECHAPPEM. 5 MM	TELLER, AUSLASSVENTILFEDER 5 MM	RETEN, RESORTE VALVULA DESCARGA 5 MM
250	12	800091578	4	SEDE MOLLA VALVOLA SCARICO	SEAT, SPRING EXHAUST	SIEGE RESSORT DU SOUPAPE ECHAPPEMENT	SITZ, AUSLASSVENTILFEDER	ASIENTO MUELLE VALVULA ESCAPE
450-510	12	8000A4135	2	SEDE MOLLA VALVOLA ASPIRAZIONE	SEAT, SPRING INTAKE	SIEGE RESSORT DU SOUPAPE ADMISSION	SITZ, ENLASS VENTILFEDER	ASIENTO MUELLE VALVULA ADMISION
450-510	12	800091578	2	SEDE MOLLA VALVOLA SCARICO	SEAT, SPRING EXHAUST	SIEGE RESSORT DU SOUPAPE ECHAPPEMENT	SITZ, AUSLASSVENTILFEDER	ASIENTO MUELLE VALVULA ESCAPE
250	13	800091579	4	MOLLA VALVOLA	SPRING, VALVE	RESSORT SOUPAPE	VENTILFEDER	MUELLE PARA VALVULA
450-510	13	8000A0568	4	MOLLA VALVOLA	SPRING, VALVE	RESSORT SOUPAPE	VENTILFEDER	MUELLE PARA VALVULA
	14	800091568	4	BILANCIERE	ARM ROCKER	CULBUTEUR	KIPPHEBEL	BALANCIN



Note Notes Notas	Pos. No. N. Index Pos.	N. Cod. Code No. Nr. Code Code Nr N. Cod.	Q.tà Q.ty Q.te M.ge C.ad	DENOMINAZIONE	NAME	DESIGNATION	BESHREIBUNG	DENOMINACION	
	250	15	8000A5436	2	ASSE BILANCIERE	AXLE, VALVE ROCKER ARM	AXE DU CULBUTEURS	KIPPHEBELACHSE	EJE BALANCIN
450-510	15	8000A5437	2	ASSE BILANCIERE	AXLE, VALVE ROCKER ARM	AXE CULBUTEURS	KIPPHEBELACHSE	EJE BALANCIN	
	250	16	8000A5435	1	DISTANZIALE A MOLLA 22,5MM	SPACER, SPRING 22.5MM	ENTRETOISE 22,5MM	ABSTANDHALTER 22,5MM	DISTANCIADOR 22,5MM
	250	16	8A00A5435	1	DISTANZIALE A MOLLA 23,5MM	SPACER, SPRING 23.5MM	ENTRETOISE 23,5MM	ABSTANDHALTER 23,5MM	DISTANCIADOR 23,5MM
450-510	16	8B00A5435	1	DISTANZIALE A MOLLA 25,8MM	SPACER, SPRING 25.8MM	ENTRETOISE 25,8MM	ABSTANDHALTER 25,8MM	DISTANCIADOR 25,8MM	
450-510	16	8C00A5435	1	DISTANZIALE A MOLLA 30,8MM	SPACER, SPRING 30.8MM	ENTRETOISE 30,8MM	ABSTANDHALTER 30,8MM	DISTANCIADOR 30,8MM	
		17	800099711	2	TAPPO DIN 908 M14X1,5	PLUG DIN 908 M14X1.5	BOUCHON DIN 908 M14X1,5	VERSCHLUSS DIN 908 M14X1,5	TAPON DIN 908 M14X1,5
		18	800047763	2	RONDELLA 17,9X14,2X1,5 MM	WASHER 17.9X14.2X1.5 MM	RONDELLE 17,9X14,2X1,5 MM	SCHEIBE 17,9X14,2X1,5 MM	ARANDELA 17,9X14,2X1,5 MM
	250	19	800091583	1	TUBO OLIO	HOSE, OIL	TUYAU HUILE	OELSCHLAUCH	MANGUITO ACEITE
450-510	19	800099834	1	TUBO OLIO	HOSE, OIL	TUYAU HUILE	OELSCHLAUCH	MANGUERA ACEITE	
		20	800091584	2	ANELLO O-RING 2018 1,78 D4,48	O-RING 2018 1.78 D4.48	JOINT TORIQUE 2018 1,78 D4,48	O-RING 2018 1,78 D4,48	JUNTA TORICA 2018 1,78 D4,48
		21	800034317	1	CUSCINETTO A SFERE 12X28X8	BEARING, BALL 12X28X8	ROULEMENT A BILLES 12X28X8	KUGELLAGER 12X28X8	COJINETE DE BOLAS 12X28X8
	250	22	80B091548	1	COPERCHIO VALVOLE	COVER, CYLINDER HEAD	COUVERCLE CULASSE	DECKEL, ZYLINDERKOPF	CUBIERTA CULATA
450-510	22	80B099836	1	COPERCHIO VALVOLE	COVER, CYLINDER HEAD	COUVERCLE CULASSE	DECKEL, ZYLINDERKOPF	CUBIERTA CULATA	
		23	800091586	1	RACCORDO SFIATO	JOINT, BREATHER	RACCORD, RENIFLARD	ANSCHLUSS, BELUFTUNG	RACOR RESPIRADERO
	250	24	800091566	1	GUARNIZIONE COPERCHIO VALVOLE	GASKET CYLINDER HEAD COVER	JOINT, COUVERCLE CULASSE	DICHTUNG, ZYLINDERKOPFDECKEL	JUNTA CUBIERTA CULATA
450-510	24	800099837	1	GUARNIZIONE COPERCHIO VALVOLE	GASKET CYLINDER HEAD COVER	JOINT, COUVERCLE CULASSE	DICHTUNG, ZYLINDERKOPFDECKEL	JUNTA CUBIERTA CULATA	
		25	800091587	4	VITE	SCREW	VIS	SCHRAUBE	TORNILLO
		26	800091588	4	RONDELLA	WASHER	RONDELLE	SCHEIBE	ARANDELA
		27	800054700	2	DADO	NUT	ECROU	MUTTER	TUERCA
		28	800062730	2	VITE TE M6X1X30 CH8	SCREW TE M6X1X30 CH8	VIS TE M6X1X30 CH8	SCHRAUBE TE M6X1X30 CH8	TORNILLO TE M6X1X30 CH8
TC-TXC	29	8000B0385	1	TAPPO M10X1,25	PLUG M10X1.25	BOUCHON M10X1,25	VERSCHLUSS M10X1,25	TAPON M10X1,25	
TE-SMR	29	8000A6736	1	SENSORE TEMPERATURA ACQUA	SENSOR WATER TEMPERATURE	CAPTEUR TEMPERATURE EAU	WASSEITEMPERATURFUEHLER	SENSOR TEMPERATURA AGUA	
		30	800091589	4	DADO	NUT	ECROU	MUTTER	TUERCA
		31	800023374	4	RONDELLA	WASHER	RONDELLE	SCHEIBE	ARANDELA
		32	800047708	4	SPINA ELASTICA 12X10 UNI 6874	SPRING PIN 12X10 UNI 6874	GOUPILLE ELASTIQUE 12X10 UNI 6874	SPANNSTIFT 12X10 UNI 6874	PASADOR ELASTICO 12X10 UNI 6874
	250	33	80A0A0232	1	TUBO OLIO	HOSE, OIL	TUYAU HUILE	OELSCHLAUCH	MANGUITO ACEITE
450-510	33	8AA0A0232	1	TUBO OLIO	HOSE, OIL	TUYAU HUILE	OELSCHLAUCH	MANGUERA ACEITE	
		34	80A0A0574	2	VITE FORATA	BANJO BOLT	VIS CREUSE	HOHLSCHRAUBE	TORNILLO TALADRADO
		35	8000A0575	4	RONDELLA	WASHER	RONDELLE	SCHEIBE	ARANDELA
		36	8W00A4162	4	PASTIGLIA VALVOLA 2,60 MM	PAD, VALVE ADJUSTING 2.60 MM	PASTILLE REGLAGE CULBETEUR 2,60 MM	VENTILKAEPFCHEN 2,60 MM	REGISTRO BALANCIN 2,60 MM
		36	8M00A4162	4	PASTIGLIA VALVOLA 2,20 MM	PAD, VALVE ADJUSTING 2.20 MM	PASTILLE REGLAGE CULBETEUR 2,20 MM	VENTILKAEPFCHEN 2,20 MM	REGISTRO BALANCIN 2,20 MM
		36	8N00A4162	4	PASTIGLIA VALVOLA 2,25 MM	PAD, VALVE ADJUSTING 2.25 MM	PASTILLE REGLAGE CULBETEUR 2,25 MM	VENTILKAEPFCHEN 2,25 MM	REGISTRO BALANCIN 2,25 MM

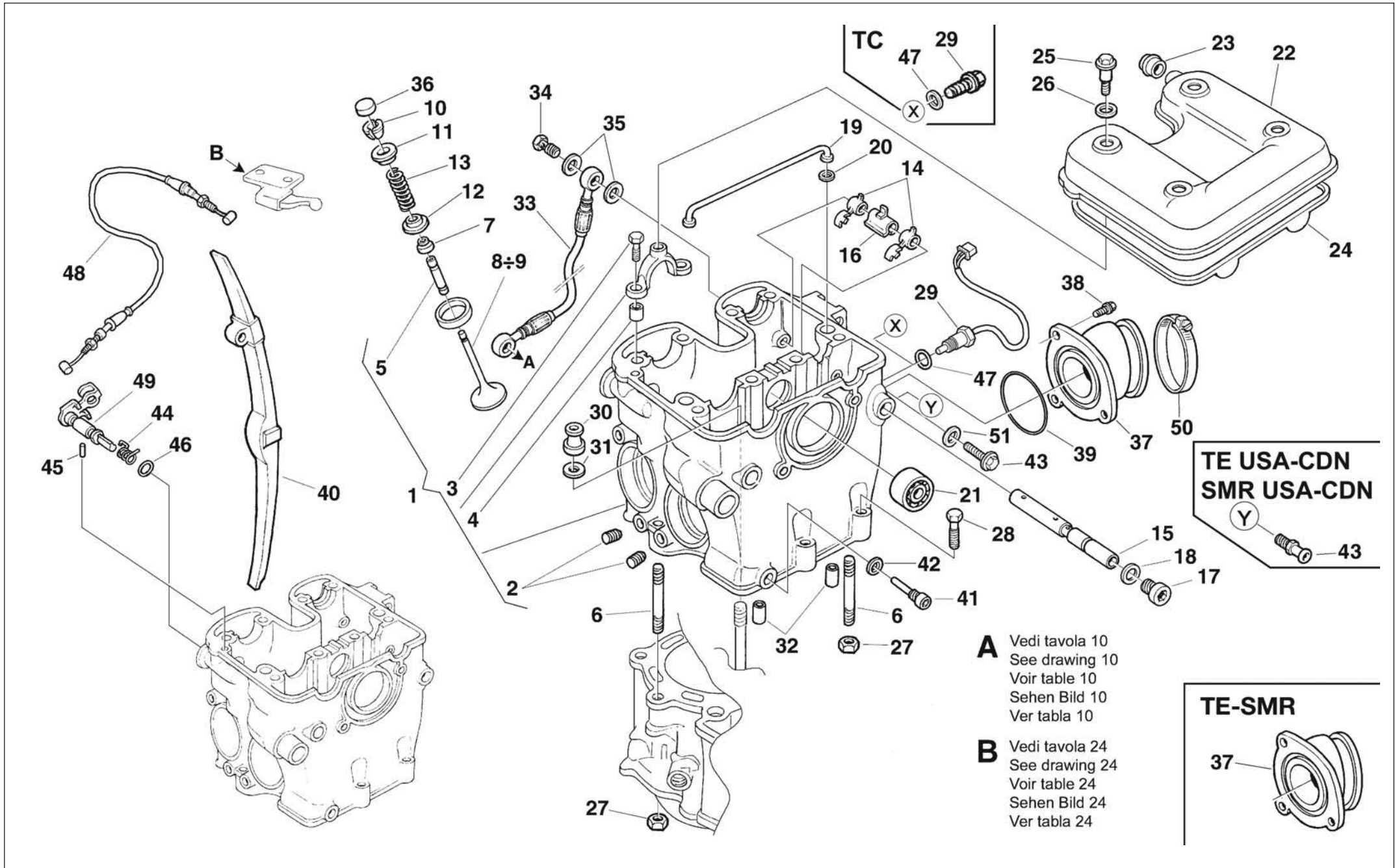

Note Notes Marka Notas	Pos. No. N. Index Pos.	N. Cod. Code No. Nr. Code Code Nr N. Cod.	Q.tà Q.ty Q.te M.ge C.ad	DENOMINAZIONE	NAME	DESIGNATION	BESHREIBUNG	DENOMINACION
	36	8R00A4162	4	PASTIGLIA VALVOLA 2,35 MM	PAD, VALVE ADJUSTING 2.35 MM	PASTILLE REGLAGE CULBETEUR 2,35 MM	VENTILKAEPPOCHEN 2,35 MM	REGISTRO BALANCIN 2,35 MM
	36	8T00A4162	4	PASTIGLIA VALVOLA 2,45 MM	PAD, VALVE ADJUSTING 2.45 MM	PASTILLE REGLAGE CULBETEUR 2,45 MM	VENTILKAEPPOCHEN 2,45 MM	REGISTRO BALANCIN 2,45 MM
	36	8L00A4162	4	PASTIGLIA VALVOLA 2,15 MM	PAD, VALVE ADJUSTING 2.15 MM	PASTILLE REGLAGE CULBETEUR 2,15 MM	VENTILKAEPPOCHEN 2,15 MM	REGISTRO BALANCIN 2,15 MM
	36	8V00A4162	4	PASTIGLIA VALVOLA 2,55 MM	PAD, VALVE ADJUSTING 2.55 MM	PASTILLE REGLAGE CULBETEUR 2,55 MM	VENTILKAEPPOCHEN 2,55 MM	REGISTRO BALANCIN 2,55 MM
	36	8P00A4162	4	PASTIGLIA VALVOLA 2,30 MM	PAD, VALVE ADJUSTING 2.30 MM	PASTILLE REGLAGE CULBETEUR 2,30 MM	VENTILKAEPPOCHEN 2,30 MM	REGISTRO BALANCIN 2,30 MM
	36	8U00A4162	4	PASTIGLIA VALVOLA 2,50 MM	PAD, VALVE ADJUSTING 2.50 MM	PASTILLE REGLAGE CULBETEUR 2,50 MM	VENTILKAEPPOCHEN 2,50 MM	REGISTRO BALANCIN 2,50 MM
	36	8J00A4162	4	PASTIGLIA VALVOLA 2,05 MM	PAD, VALVE ADJUSTING 2.05 MM	PASTILLE REGLAGE CULBETEUR 2,05 MM	VENTILKAEPPOCHEN 2,05 MM	REGISTRO BALANCIN 2,05 MM
	36	8H00A4162	4	PASTIGLIA VALVOLA 2,00 MM	PAD, VALVE ADJUSTING 2.00 MM	PASTILLE REGLAGE CULBETEUR 2,00 MM	VENTILKAEPPOCHEN 2,00 MM	REGISTRO BALANCIN 2,00 MM
	36	8G00A4162	4	PASTIGLIA VALVOLA 1,95 MM	PAD, VALVE ADJUSTING 1.95 MM	PASTILLE REGLAGE CULBETEUR 1,95 MM	VENTILKAEPPOCHEN 1,95 MM	REGISTRO BALANCIN 1,95 MM
	36	8F00A4162	4	PASTIGLIA VALVOLA 1,90 MM	PAD, VALVE ADJUSTING 1.90 MM	PASTILLE REGLAGE CULBETEUR 1,90 MM	VENTILKAEPPOCHEN 1,90 MM	REGISTRO BALANCIN 1,90 MM
	36	8E00A4162	4	PASTIGLIA VALVOLA 1,85 MM	PAD, VALVE ADJUSTING 1.85 MM	PASTILLE REGLAGE CULBETEUR 1,85 MM	VENTILKAEPPOCHEN 1,85 MM	REGISTRO BALANCIN 1,85 MM
	36	8D00A4162	4	PASTIGLIA VALVOLA 1,80 MM	PAD, VALVE ADJUSTING 1.80 MM	PASTILLE REGLAGE CULBETEUR 1,80 MM	VENTILKAEPPOCHEN 1,80 MM	REGISTRO BALANCIN 1,80 MM
	36	8C00A4162	4	PASTIGLIA VALVOLA 1,75 MM	PAD, VALVE ADJUSTING 1.75 MM	PASTILLE REGLAGE CULBETEUR 1,75 MM	VENTILKAEPPOCHEN 1,75 MM	REGISTRO BALANCIN 1,75 MM
	36	8B00A4162	4	PASTIGLIA VALVOLA 1,70 MM	PAD, VALVE ADJUSTING 1.70 MM	PASTILLE REGLAGE CULBETEUR 1,70 MM	VENTILKAEPPOCHEN 1,70 MM	REGISTRO BALANCIN 1,70 MM
	36	8A00A4162	4	PASTIGLIA VALVOLA 1,65 MM	PAD, VALVE ADJUSTING 1.65 MM	PASTILLE REGLAGE CULBETEUR 1,65 MM	VENTILKAEPPOCHEN 1,65 MM	REGISTRO BALANCIN 1,65 MM
	36	8000A4162	4	PASTIGLIA VALVOLA 1,60 MM	PAD, VALVE ADJUSTING 1.60 MM	PASTILLE REGLAGE CULBETEUR 1,60 MM	VENTILKAEPPOCHEN 1,60 MM	REGISTRO BALANCIN 1,60 MM
	36	8S00A4162	4	PASTIGLIA VALVOLA 2,40 MM	PAD, VALVE ADJUSTING 2.40 MM	PASTILLE REGLAGE CULBETEUR 2,40 MM	VENTILKAEPPOCHEN 2,40 MM	REGISTRO BALANCIN 2,40 MM
	36	8K00A4162	4	PASTIGLIA VALVOLA 2,10 MM	PAD, VALVE ADJUSTING 2.10 MM	PASTILLE REGLAGE CULBETEUR 2,10 MM	VENTILKAEPPOCHEN 2,10 MM	REGISTRO BALANCIN 2,10 MM
TC-TXC 250	37	8000B0377	1	COLLETTORE ASPIRAZIONE	MANIFOLD, INTAKE	COLLECTEUR ADMISSION	EINSATZ KRUEMMER	COLECTOR ADMISION
TC-TXC 450	37	8000B0379	1	COLLETTORE ASPIRAZIONE	MANIFOLD, INTAKE	COLLECTEUR ADMISSION	EINSATZ KRUEMMER	COLECTOR ADMISION
TC-TXC 510	37	8000B0596	1	COLLETTORE ASPIRAZIONE	MANIFOLD, INTAKE	COLLECTEUR ADMISSION	EINSATZ KRUEMMER	COLECTOR ADMISION
TE 250	37	8000B0369	1	COLLETTORE ASPIRAZIONE	MANIFOLD, INTAKE	COLLECTEUR ADMISSION	EINSATZ KRUEMMER	COLECTOR ADMISION
TE-SMR 450-510	37	8000B0357	1	COLLETTORE ASPIRAZIONE	MANIFOLD, INTAKE	COLLECTEUR ADMISSION	EINSATZ KRUEMMER	COLECTOR ADMISION
TC-TXC	38	800062728	3	VITE TEF M6X1X20 CH8	SCREW TEF M6X1X20 CH8	VIS TEF M6X1X20 CH8	SCHRAUBE TEF M6X1X20 CH8	TORNILLO TEF M6X1X20 CH8
TE-SMR	38	60N102509	3	VITE TCEI M6X1X20	SCREW TCEI M6X1X20	VIS TCEI M6X1X20	SCHRAUBE TCEI M6X1X20	TORNILLO TCEI M6X1X20
TC-TXC	39	8A0028553	1	ANELLO O-RING 3200	O-RING 3200	JOINT TORIQUE 3200	O-RING 3200	JUNTA TORICA 3200
	40	800091553	1	PATTINO GUIDA CATENA DISTRIBUZIONE	GUIDE, TIMING CHAIN	PATIN GUIDE CHAINE DISTRIBUTION	STUEKETTENFUEHRUNG	GUIA CADENA DISTRIBUCION
	41	161535902	1	VITE	SCREW	VIS	SCHRAUBE	TORNILLO
	42	800045194	1	RONDELLA 14X8,2X1	WASHER 14X8.2X1	RONDELLE 14X8,2X1	SCHEIBE 14X8,2X1	ARANDELA 14X8,2X1
NO USA	43	8D0067997	1	VITE TE M5X0,8X8	SCREW TE M5X0.8X8	VIS TE M5X0,8X8	SCHRAUBE TE M5X0,8X8	TORNILLO TE M5X0,8X8
USA-CAN	43	800093915	1	RACCORDO CANISTER	JOINT CANISTER	RACCORD CANISTER	ANSCHLUSS CANISTER	RACOR CANISTER
	44	800099687	1	MOLLA ALZAVOLVILE	SPRING	RESSORT	FEDER	MUELLE

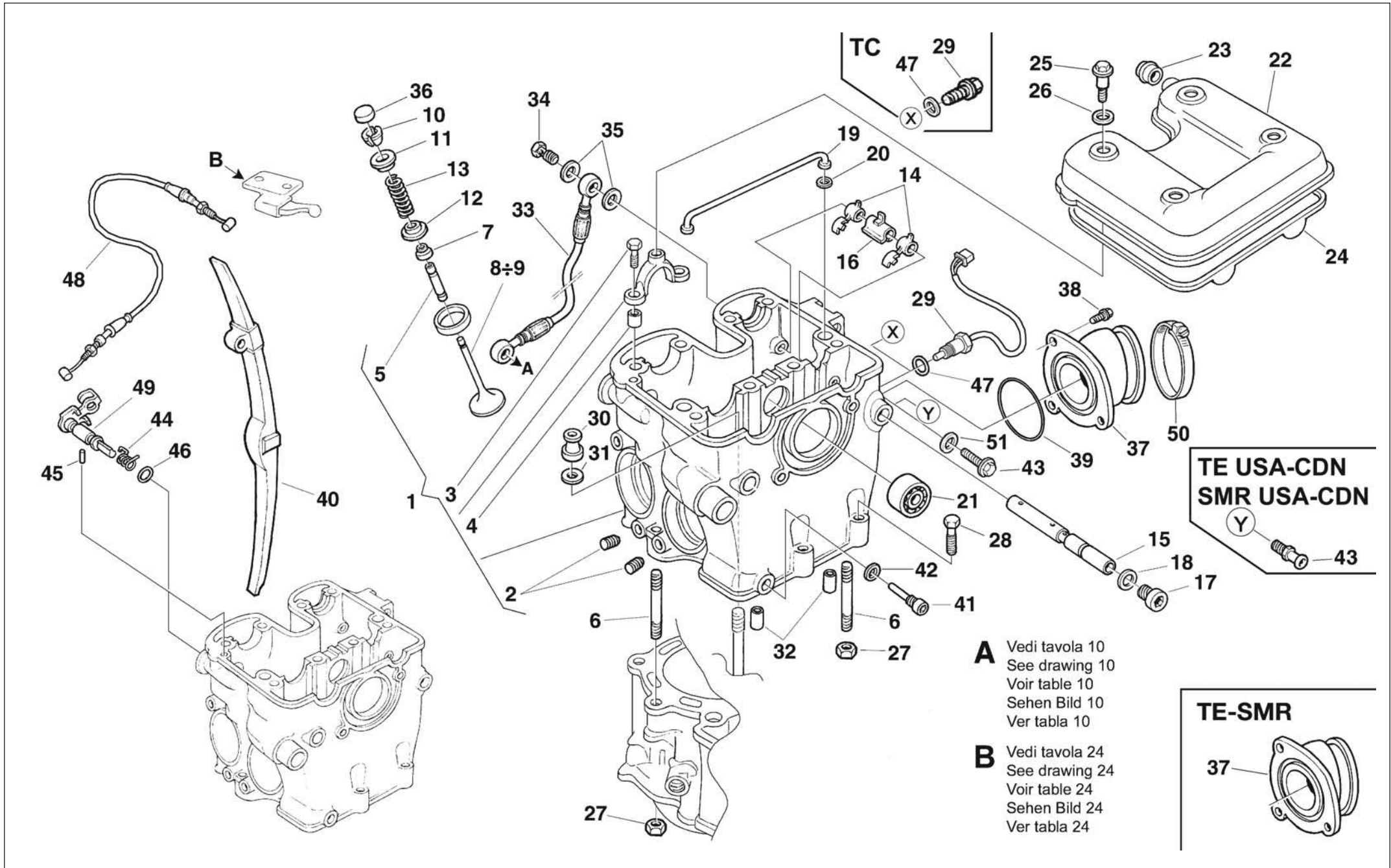

**A** Vedi tavola 10  
See drawing 10  
Voir table 10  
Sehen Bild 10  
Ver tabla 10

**B** Vedi tavola 24  
See drawing 24  
Voir table 24  
Sehen Bild 24  
Ver tabla 24





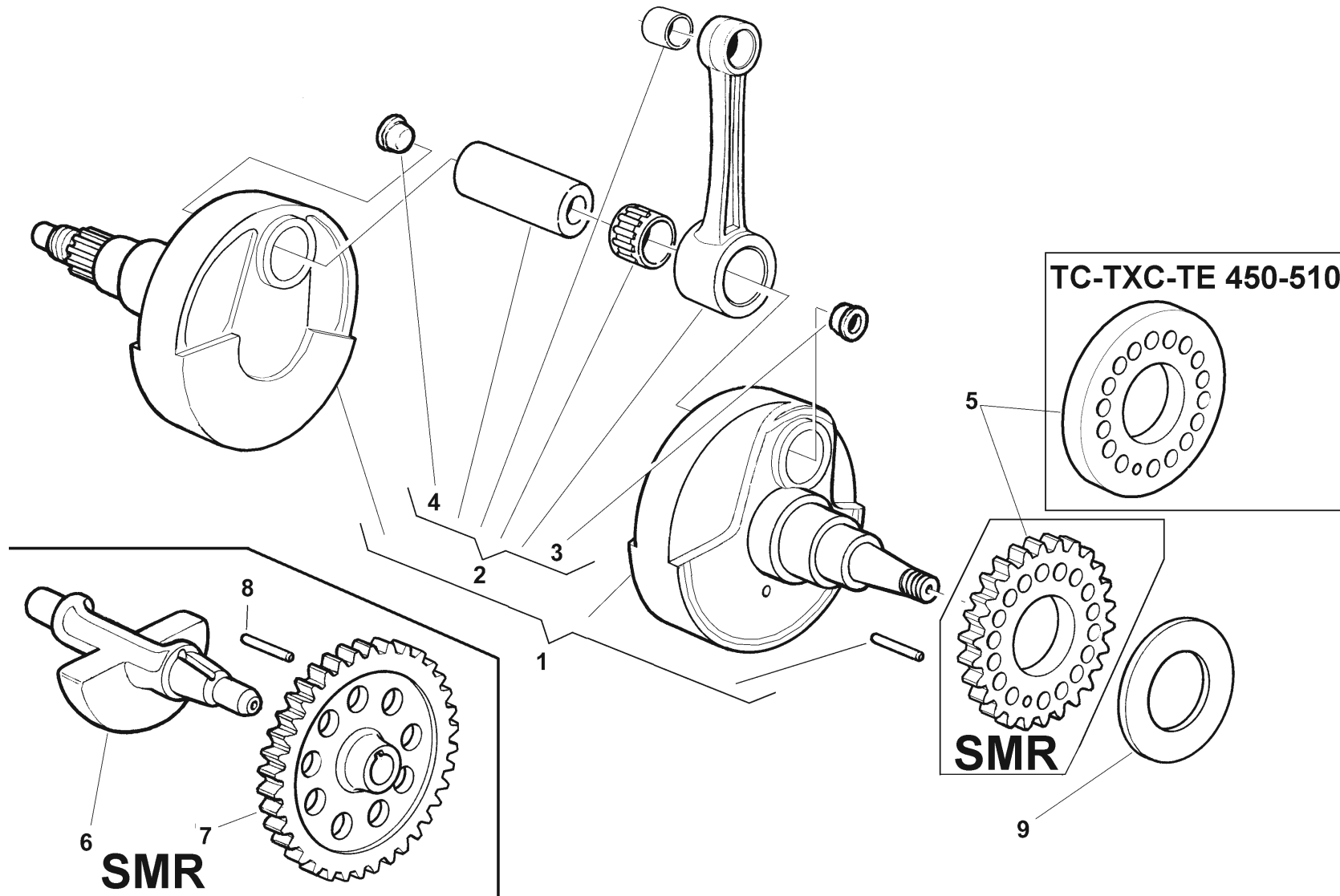

Note Notes Notas	Pos. No. Index Pos.	N. Cod. Code No. Nr. Code Code Nr N. Cod.	Q.tà Q.ty Q.te M.ge C.ad	DENOMINAZIONE	NAME	DESIGNATION	BESHREIBUNG	DENOMINACION	
	250	1	8000A6186	1	ALBERO MOTORE	CRANKSHAFT	VILEBREQUIN	KURBELWELLE	CIGÜENAL
	450	1	8000A4165	1	ALBERO MOTORE	CRANKSHAFT	VILEBREQUIN	KURBELWELLE	CIGÜENAL
	510	1	8000A4178	1	ALBERO MOTORE	CRANKSHAFT	VILEBREQUIN	KURBELWELLE	CIGÜENAL
	250	2	8000A5703	1	BIELLA COMPLETA	CONNECTING ROD ASSY	BIELLE COMPLETE	PLEUELSTANGE KPL.	BIELA COMPLETA
	450	2	8000A4166	1	BIELLA COMPLETA	CONNECTING ROD ASSY	BIELLE COMPLETE	PLEUELSTANGE KPL.	BIELA COMPLETA
	510	2	8000A4179	1	BIELLA COMPLETA	CONNECTING ROD ASSY	BIELLE COMPLETE	PLEUELSTANGE KPL.	BIELA COMPLETA
	250	3	8B0057196	1	TAPPO	PLUG	BOUCHON	VERSCHLUSS	TAPON
	450-510	3	800057196	1	TAPPO 12X6X10	PLUG 12X6X10	BOUCHON 12X6X10	VERSCHLUSS 12X6X10	TAPON 12X6X10
	250	4	8B0057196	1	TAPPO	PLUG	BOUCHON	VERSCHLUSS	TAPON
	450-510	4	800057196	1	TAPPO 12X6X10	PLUG 12X6X10	BOUCHON 12X6X10	VERSCHLUSS 12X6X10	TAPON 12X6X10
	450 TE-TXC	5	8000A6252	1	MASSA INERZIALE	MASS, INERTIA	MASSE INERTIEL	MASSE TRAEIGHEIT	MASA INERCIAL
	SMR	5	800099915	1	INGRANAGGIO CONDUTTORE CONTRALBERO Z30	GEAR, BALANCER DRIVE T30	ENGRANAGE MENANT CONTRE-ARBRE D30	TREIBENDES ZAHNRAD AUSGLEICHWELLE Z30	ENGRANAJE CONDUCTOR CONTRAARBOL D30
	TE-TXC 510	5	8000A6253	1	MASSA INERZIALE	MASS, INERTIA	MASSE INERTIEL	MASSE TRAEIGHEIT	MASA INERCIAL
	450 SMR	6	8000A4173	1	CONTRALBERO BILANCIAMENTO	BALANCER, CRANK	ARBRE BALANCIEUR	WELLE, AUSGLEICH	ARBOL BALANCADOR
	SMR 510	6	8000A3435	1	CONTRALBERO BILANCIAMENTO	BALANCER, CRANK	ARBRE BALANCIEUR	WELLE, AUSGLEICH	ARBOL BALANCADOR
	450 SMR	7	8000A4174	1	INGRANAGGIO CONDOTTO Z30	GEAR, DRIVEN T30	ENGRENAGE ENTRAINE D30	ANGETRIEBENES ZAHNRAD Z30	ENGRANAJE ACCIONADO D30
	SMR 510	7	800099916	1	INGRANAGGIO CONDOTTO Z30	GEAR, DRIVEN T30	ENGRENAGE ENTRAINE D30	ANGETRIEBENES ZAHNRAD Z30	ENGRANAJE ACCIONADO D30
	SMR	8	8A0047773	1	RULLINO	ROLLER	ROULEAU	ROLLE	RODILLO
		9	8C0028183	1	RONDELLA RASAMENTO 0,5 MM	WASHER, LEVER FRONT	RONDELLE DE BUTEE 0,5 MM	DISTANZSCHEIBE 0,5 MM	ARANDELA DE SEPARACION 0,5 MM
		9	8A0028183	1	RONDELLA RASAMENTO 0,3 MM	THRUST WASHER 0.3 MM	RONDELLE DE BUTEE 0,3 MM	DISTANZSCHEIBE 0,3 MM	ARANDELA DE SEPARACION 0,3 MM
		9	8D0028183	1	RONDELLA RASAMENTO 0,6 MM	THRUST WASHER 0.6 MM	RONDELLE DE BUTEE 0,6 MM	DISTANZSCHEIBE 0,6 MM	ARANDELA DE SEPARACION 0,6 MM
		9	8H0028183	1	RONDELLA RASAMENTO 40X32X1	THRUST WASHER 40X32X1	RONDELLE DE BUTEE 40X32X1	DISTANZSCHEIBE 40X32X1	ARANDELA DE SEPARACION 40X32X1
		9	8F0028183	1	RONDELLA RASAMENTO 0,8 MM	THRUST WASHER 0.8 MM	RONDELLE DE BUTEE 0,8 MM	DISTANZSCHEIBE 0,8 MM	ARANDELA DE SEPARACION 0,8 MM

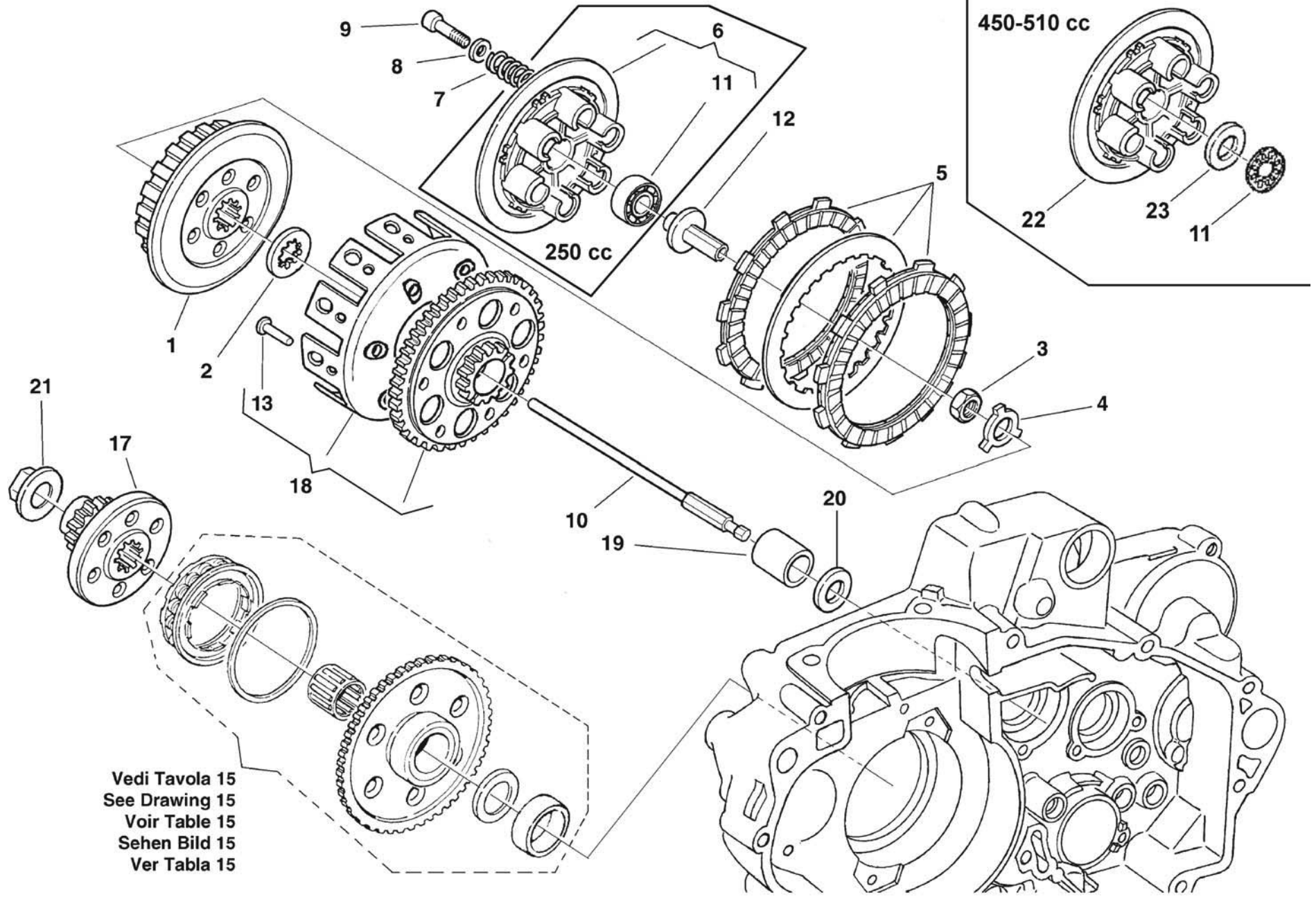

Vedi Tavola 15  
See Drawing 15  
Voir Table 15  
Sehen Bild 15  
Ver Tabla 15

Note Notes Notes Marke Notas	Pos. No. N. Index Pos.	N. Cod. Code No. Nr. Code Code Nr N. Cod.	Q.tà Q.ty Q.te M.ge C.ad	DENOMINAZIONE	NAME	DESIGNATION	BESHREIBUNG	DENOMINACION
450-510	1	8000A9746	1	MOZZETTO FRIZIONE	BOSS, CLUTCH	MOYEU EMBRAYAGE PORTE-DISQUE	KUPPLUNGSSCHEIBENHALTERNABE	CUBO EMBRAGUE PORTA-DISCOS
TC 250	1	8B00A6465	1	MOZZETTO FRIZIONE	BOSS CLUTCH	MOYEU EMBRAYAGE PORTE-DISQUE	KUPPLUNGSSCHEIBENHALTERNABE	CUBO EMBRAGUE PORTA-DISCOS
TE-TXC 250	1	8C0096746	1	MOZZETTO FRIZIONE	BOSS, CLUTCH	MOYEU EMBRAYAGE PORTE-DISQUE	KUPPLUNGSSCHEIBENHALTERNABE	CUBO EMBRAGUE PORTA-DISCOS
TC 250-450-510	2	800038350	1	RONDELLA 46X22X19	WASHER 46X22X19	RONDELLE 46X22X19	SCHEIBE 46X22X19	ARANDELA 46X22X19
TXC-TE 250	2	8A0038350	1	RONDELLA 46X22X19X3	WASHER 46X22X19X3	RONDELLE 46X22X19X3	SCHEIBE 46X22X19X3	ARANDELA 46X22X19X3
	3	800036856	1	DADO M18X1	NUT M18X1	ECROU M18X1	MUTTER M18X1	TUERCA M18X1
	4	800036857	1	RONDELLA DI SICUREZZA 18MM	WASHER, LOCK 18MM	RONDELLE VERROULAGE 18MM	SICHERUNGSSCHEIBE 18MM	ARANDELA CIERRE 18MM
450-510	5	8000A9764	1	SERIE DISCHI FRIZIONE	CLUTCH DISC SET	JEU DISQUES EMBRAYAGE	KUPPLUNGSSCHEIBENSATZ	JUEGO DISCOS EMBRAGUE
TC 250	5	8A00A0611	1	SERIE DISCHI FRIZIONE	CLUTCH DISC SET	JEU DISQUES EMBRAYAGE	KUPPLUNGSSCHEIBENSATZ	JUEGO DISCOS EMBRAGUE
TXC-TE 250	5	8000A0611	1	SERIE DISCHI FRIZIONE	CLUTCH DISC SET	JEU DISQUES EMBRAYAGE	KUPPLUNGSSCHEIBENSATZ	JUEGO DISCOS EMBRAGUE
250	6	800081508	1	PIATTO PORTAMOLLE FRIZIONE	PLATE, CLUTCH PRESSURE	DISQUE DE PRESSION D'EMBRAYAGE	DRUECKPLATTE, KUPPLUNG	PLACA DE PRESION, EMBRAGUE
	7	8000A0730	6	MOLLA FRIZIONE	SPRING, CLUTCH	RESSORT EMBRAYAGE	KUPPLUNGSFEDER	MUELLE EMBRAGUE
250	8	800081519	6	SCODELLINO MOLLA FRIZIONE	SEAT, CLUTCH SPRING	COUVETTE PORTE-RESSORT EMBRAYAGE	BECHER, KUPPLUNGSFEDER	CUBETA PORTAMUELLE EMBRAGUE
450-510	8	8A0039248	6	SCODELLINO MOLLA FRIZIONE	SEAT, CLUTCH SPRING	COUVETTE PORTE-RESSORT EMBRAYAGE	BECHER, KUPPLUNGSFEDER	CUBETA PORTAMUELLE EMBRAGUE
250	9	60N102510	6	VITE BRUGOLA M6X25	BOLT, SOCKET HEAD M6X25	VIS TETE HEXAGONALE CREUSE M6X25	INNENSECHSKANTSCHRAUBE M6X25	TORNILLO, ALLEN M6X25
450-510	9	800062728	6	VITE TEF M6X1X20 CH8	SCREW TEF M6X1X20 CH8	VIS TEF M6X1X20 CH8	SCHRAUBE TEF M6X1X20 CH8	TORNILLO TEF M6X1X20 CH8
450-510	10	8A00B0497	1	ASTA SPINGIFRIZIONE	ROD-PUSH, CLUTCH	TIGE POUSSEE EMBRAYAGE	KUPPLUNGSGESTAENGE	VARILLA EMPUJE DISCO EMBRAGUE
TC 250	10	8000A2654	1	ASTA SPINGIFRIZIONE	ROD-PUSH, CLUTCH	TIGE POUSSEE EMBRAYAGE	KUPPLUNGSGESTAENGE	VARILLA EMPUJE DISCO EMBRAGUE
TXC-TE 250	10	800099953	1	ASTA SPINGIFRIZIONE	ROD-PUSH, CLUTCH	TIGE POUSSEE EMBRAYAGE	KUPPLUNGSGESTAENGE	VARILLA EMPUJE DISCO EMBRAGUE
250	11	800034317	1	CUSCINETTO A SFERE 12X28X8	BEARING, BALL 12X28X8	ROULEMENT A BILLES 12X28X8	KUGELLAGER 12X28X8	COJINETE DE BOLAS 12X28X8
450-510	11	800035780	1	CUSCINETTO ASSIALE REGGISPINTA	BEARING, THRUST	ROULEMENT BUTEE	DRUCKLAGER	COJINETE EMPUJADOR
450-510	12	8000A9749	1	PUNTALINO FRIZIONE	PIECE, CLUTCH PUSH	BARRE PRESSION	DRUCKSTANGE	PISTON BOMBIN EMBRAGUE
TC 250	12	8B00A3509	1	PUNTALINO FRIZIONE	PIECE, CLUTCH PUSH	BARRE PRESSION	DRUCKSTANGE	PISTON BOMBIN EMBRAGUE
TXC-TE 250	12	8000A0882	1	PUNTALINO FRIZIONE	PIECE, CLUTCH PUSH	BARRE PRESSION	DRUCKSTANGE	PISTON BOMBIN EMBRAGUE
450-510	13	800048236	8	RIBATTINO TSP 5X22 UNI 752	RIVET TSP 5X22 UNI 752	RIVET TSP 5X22 UNI 752	NIET TSP 5X22 UNI 752	REMACHE TSP 5X22 UNI 752
450-510	17	8000A5921	1	INGRANAGGIO CONDUTTORE Z23	GEAR, DRIVE T23	ENGRENAGE MENANT D23	TREIBENDES ZAHNRAD Z23	ENGRANAJE CONDUCTOR D23
TC 250	17	8000A6305	1	INGRANAGGIO CONDUTTORE Z24	GEAR, DRIVE T24	ENGRENAGE MENANT D24	TREIBENDES ZAHNRAD Z24	ENGRANAJE CONDUCTOR D24
TXC-TE 250	17	8000A0749	1	INGRANAGGIO CONDUTTORE Z24	GEAR, DRIVE T24	ENGRENAGE MENANT D24	TREIBENDES ZAHNRAD Z24	ENGRANAJE CONDUCTOR D24
450-510	18	8000A9202	1	CAMPANA FRIZIONE	CLUTCH HOUSING	CLOCHE EMBRAYAGE	KUPPLUNGSKASTEN	CAMPANA EMBRAGUE
TC 250	18	8000A7958	1	CAMPANA FRIZIONE	GEAR, PRIMARY DRIVEN	CLOCHE D'EMBRAIAGE	KUPPLUNGSKORB	CAMPANA DE EMBRAGUE
TXC-TE 250	18	8000A0751	1	CAMPANA FRIZIONE	CLUTCH HOUSING	CLOCHE EMBRAYAGE	KUPPLUNGSKASTEN	CAMPANA EMBRAGUE
	19	161538801	1	BOCCOLA	BUSH	DOUILLE	BUCHSE	BUJE
	20	8E0030053	1	RONDELLA RASAMENTO 38X25,2	THRUST WASHER 38X25,2	RONDELLE DE BUTEE 38X25,2	DISTANZSCHEIBE 38X25,2	ARANDELA DE SEPARACION 38X25,2

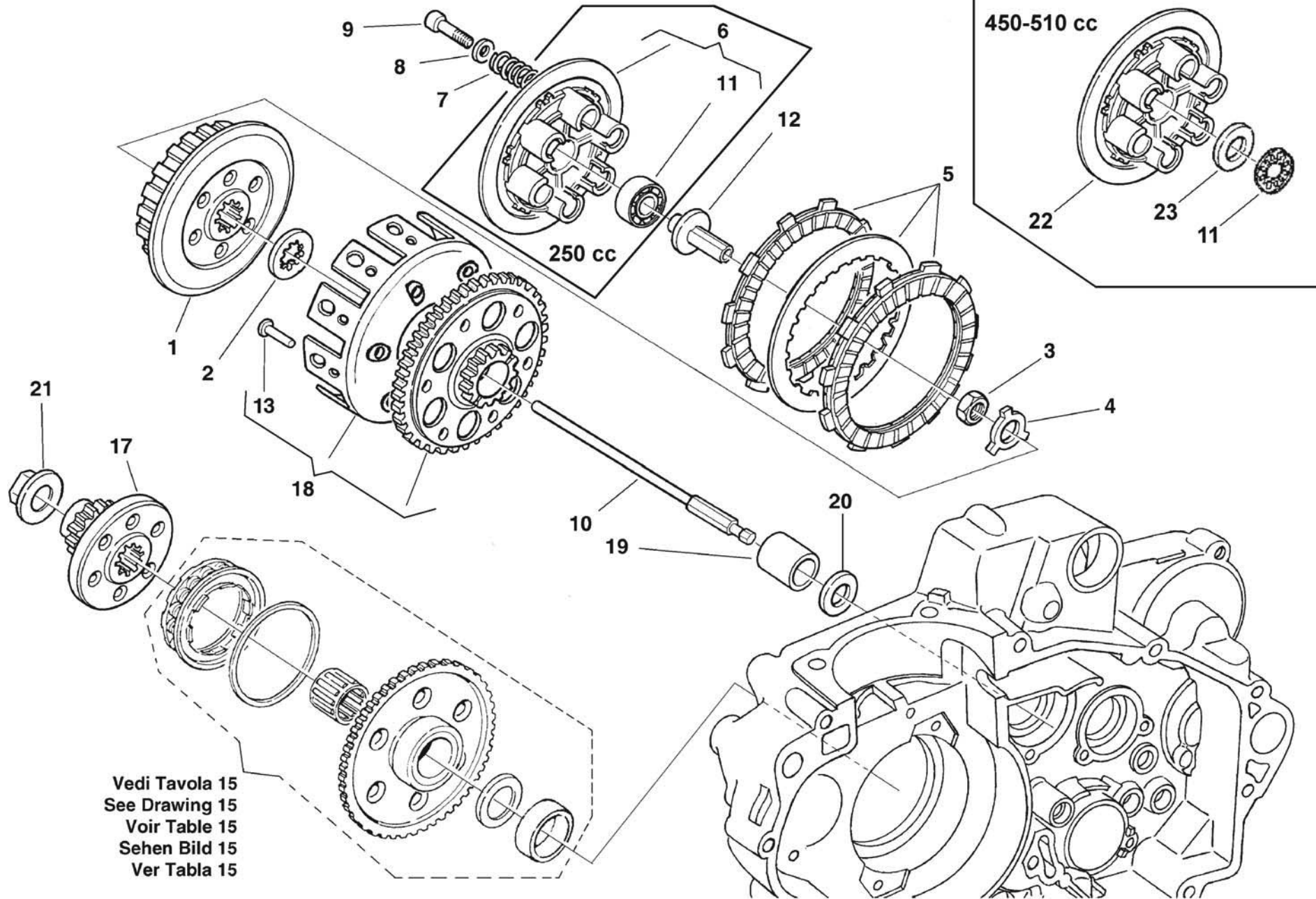

Vedi Tavola 15  
See Drawing 15  
Voir Table 15  
Sehen Bild 15  
Ver Tabla 15



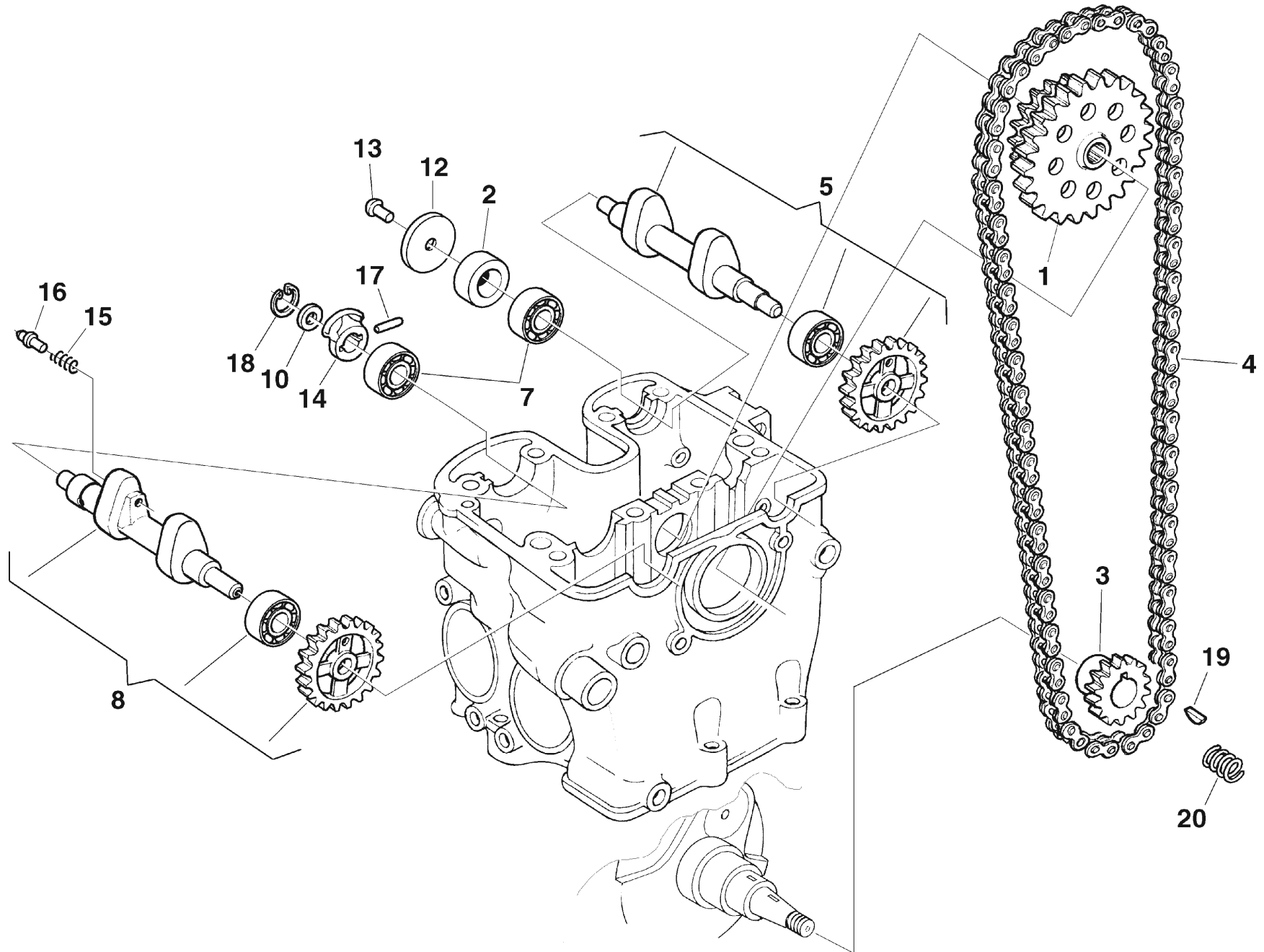





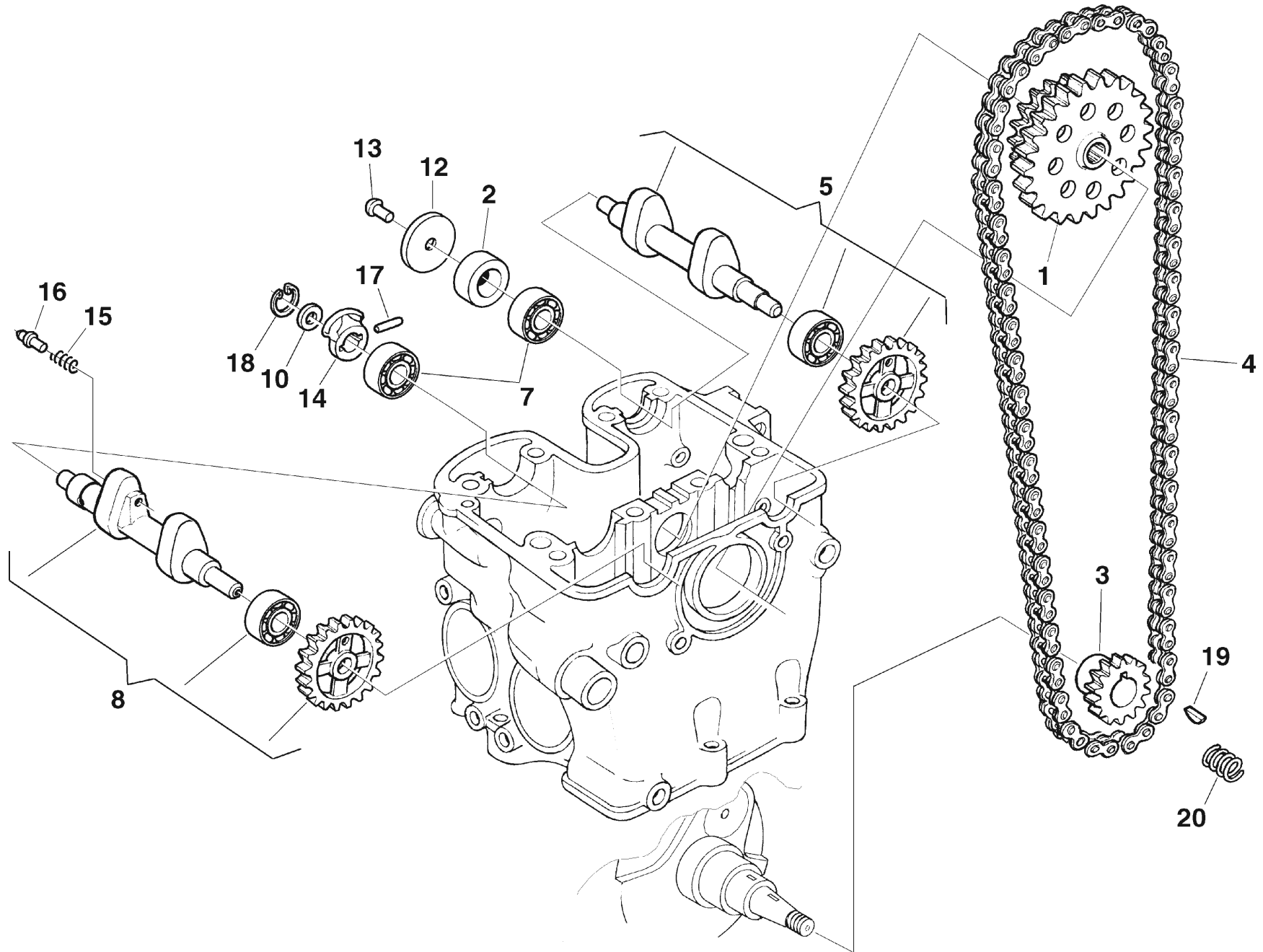



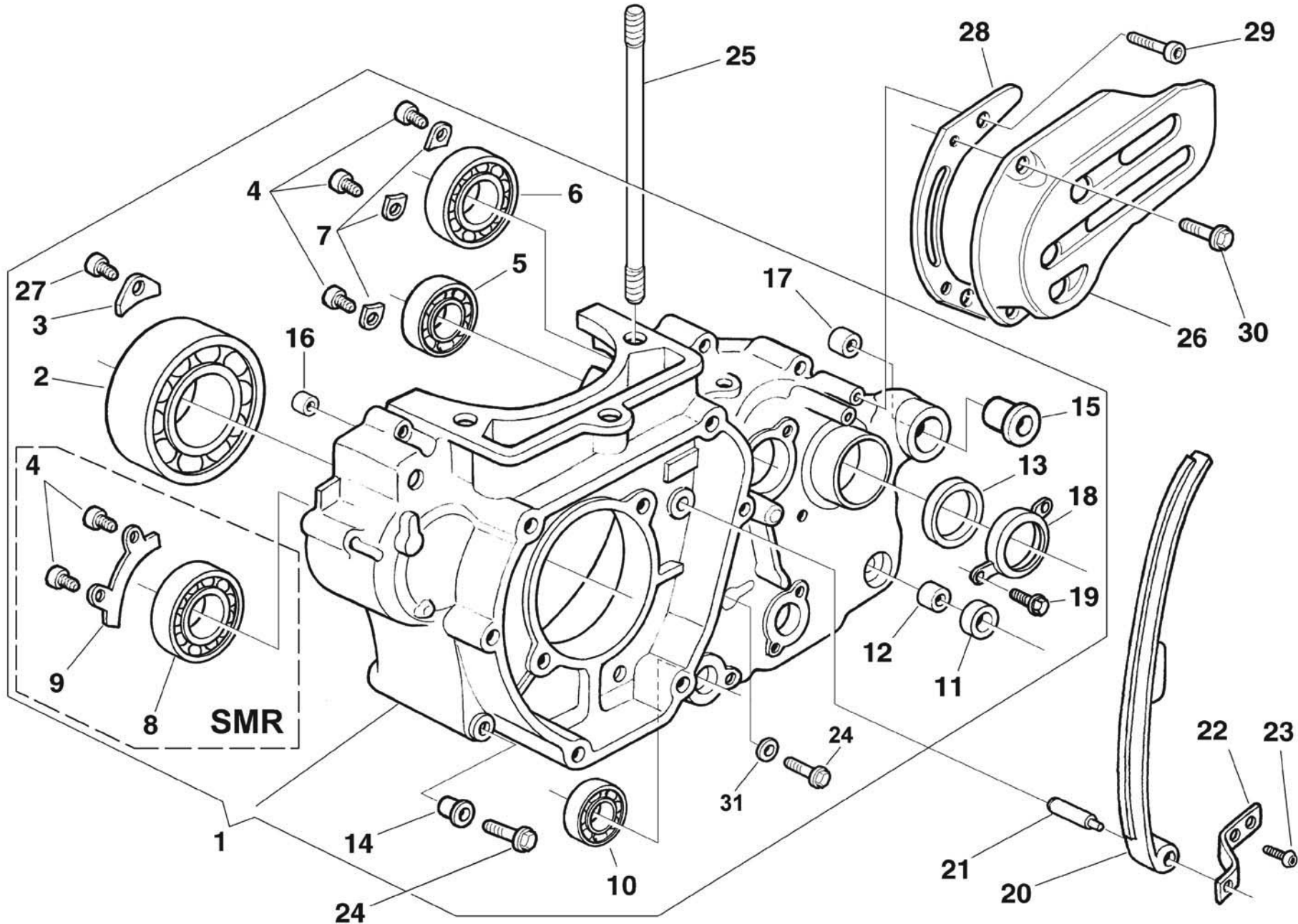

Note Notes Notes Marke Notas	Pos. No. N. Index Pos.	N. Cod. Code No. Nr. Code Code Nr N. Cod.	Q.tà Q.ty Q.te M.ge C.ad	DENOMINAZIONE	NAME	DESIGNATION	BESHREIBUNG	DENOMINACION
SMR	1	8A00A5671	1	CARTER MOTORE	CRANKCASE SET	CARTER MOTEUR	KURBELWELLENGEHAUSE	CARTER MOTOR
TC 250	1	8A00A6443	1	CARTER MOTORE	CRANKCASE SET	CARTER MOTEUR	KURBELWELLENGEHAUSE	CARTER MOTOR
TC 450-510	1	8A00A6445	1	CARTER MOTORE	CRANKCASE SET	CARTER MOTEUR	KURBELWELLENGEHAUSE	CARTER MOTOR
TXC-TE 250	1	8A00A5603	1	CARTER MOTORE	CRANKCASE SET	CARTER MOTEUR	KURBELWELLENGEHAUSE	CARTER MOTOR
TXC-TE 450-510	1	8A00A7275	1	CARTER MOTORE	CRANKCASE SET	CARTER MOTEUR	KURBELWELLENGEHAUSE	CARTER MOTOR
250	2	8000A2767	1	CUSCINETTO A SFERE 30X62X16 MM	BALL BEARING 30X62X16 MM	ROULEMENT A BILLES 30X62X16 MM	KUGELLAGER 30X62X16 MM	COJINETE DE BOLAS 30X62X16 MM
450-510	2	800099846	1	CUSCINETTO A SFERE 30X72X19 MM	BALL BEARING 30X72X19 MM	ROULEMENT A BILLES 30X72X19 MM	KUGELLAGER 30X72X19 MM	COJINETE DE BOLAS 30X72X19 MM
	3	800097941	2	PIASTRINA RITEGNO CUSCINETTO	RETAINER, BEARING	PLAQUE ARRET ROULEMENT	STOPPLATTE, LAGER	PLACA RETENCION COJINETE
SMR	4	8A0055241	5	VITE TCEI M6X1,00X14 CH5	SCREW TCEI M6X1.00X14 CH5	VIS TCEI M6X1,00X14 CH5	SCHRAUBE TCEI M6X1,00X14 CH5	TORNILLO TCEI M6X1,00X14 CH5
TE-TC-TXC	4	8A0055241	3	VITE TCEI M6X1,00X14 CH5	SCREW TCEI M6X1.00X14 CH5	VIS TCEI M6X1,00X14 CH5	SCHRAUBE TCEI M6X1,00X14 CH5	TORNILLO TCEI M6X1,00X14 CH5
	5	800099847	1	CUSCINETTO A SFERE 17X40X12	BEARING, DRIVE SHAFT, RH 17X40X12	ROULEMENT A BILLES 17X40X12	KUGELLAGER 17X40X12	COJINETE DE BOLAS 17X40X12
	6	800043567	1	CUSCINETTO A SFERE 52X25X15	BALL BEARING 52X25X15	ROULEMENT A BILLES 52X25X15	KUGELLAGER 52X25X15	COJINETE DE BOLAS 52X25X15
	7	800051746	3	PIASTRINA RITEGNO CUSCINETTO	RETAINER, BEARING	PLAQUE ARRET ROULEMENT	STOPPLATTE, LAGER	PLACA RETENCION COJINETE
SMR	8	8A0019768	1	CUSCINETTO A SFERE	BEARING, BALL	ROULEMENT A BILLES	KUGELLAGER	COJINETE DE BOLAS
SMR	9	800091602	1	PIASTRINA RITEGNO CUSCINETTO	RETAINER, BEARING	PLAQUE ARRET ROULEMENT	STOPPLATTE, LAGER	PLACA RETENCION COJINETE
	10	800065884	1	CUSCINETTO A SFERE 37X25X7	BEARING, RADIAL BALL 37X25X7	ROULEMENT A BILLES 37X25X7	KUGELLAGER 37X25X7	COJINETE DE BOLAS 37X25X7
	11	800034451	1	PARAOLIO 12X19X5	OIL SEAL 12X19X5	BAGUE D'ETANCHEITE 12X19X5	WELLENDICHTRING 12X19X5	RETEN DE ACEITE 12X19X5
	12	8A0065847	1	BOCCOLA	BUSH	DOUILLE	BUCHSE	BUJE
	13	800059977	1	PARAOLIO 32X40X5	SEAL, OIL 32X40X5	BAGUE D'ETANCHEITE 32X40X5	WELLENDICHTRING 32X40X5	RETEN DE ACEITE 32X40X5
	14	161077703	2	BOCCOLA FLANGIATA	BUSH WITH COLLAR	DOUILLE BRIDEE	GEFLANSCHBUCHSE	CASQUILLO REBORDEADO
	15	800073500	1	BOCCOLA FORCELLONE	BUSHING, SWING ARM	DOUILLE, BRAS OSCILLANT	HULSE, SCHWINGE	COLLAR BASCULANTE
	16	161077601	1	BOCCOLA 13X8,5X15	BUSH 13X8.5X15	DOUILLE 13X8,5X15	BUCHSE 13X8,5X15	BUJE 13X8,5X15
	17	161459002	1	BOCCOLA 22X17,5X15	BUSH 22X17.5X15	DOUILLE 22X17,5X15	BUCHSE 22X17,5X15	BUJE 22X17,5X15
	18	800099850	1	PIASTRINA RITEGNO PARAOLIO	PLATE HOLDING OIL SEAL	PLAQUETTE FIXATION JBAGUE ETANCHEITE	HALTEPLATTE WELLENDICHTRING	PLACA SUJECION RETEN ACEITE
	19	800066525	2	VITE TEF M5X0,8X12	SCREW TEF M5X0.8X12	VIS TEF M5X0,8X12	SCHRAUBE TEF M5X0,8X12	TORNILLO TEF M5X0,8X12
250-450	20	800091555	1	PATTINO TENDICATENA DISTRIBUZIONE	TENSIONER, CAM CHAIN	PATIN TENDEUR CHAINE DISTRIBUTION	STUEKETTENGLEITFUEHRUNG	PATIN TENSOR CADENA DISTRIBUCION
510	20	8000A3504	1	PATTINO TENDICATENA DISTRIBUZIONE	TENSIONER, CAM CHAIN	PATIN TENDEUR CHAINE DISTRIBUTION	STUEKETTENGLEITFUEHRUNG	PATIN TENSOR CADENA DISTRIBUCION
	21	800099704	1	PERNO	PIN	PIVOT	BOLZEN	PERNO
	22	800099705	1	PIASTRINA	PLATE	PLAQUETTE	PLAETTCHEN	PLETINA
	23	800066774	2	VITE TCIC M4X0,7X8	SCREW TCIC M4X0.7X8	VIS TCIC M4X0,7X8	SCHRAUBE TCIC M4X0,7X8	TORNILLO TCIC M4X0,7X8
	24	800062731	12	VITE TEF M6X1X45	SCREW TEF M6X1X45	VIS TEF M6X1X45	SCHRAUBE TEF M6X1X45	TORNILLO TEF M6X1X45
250	25	8C0081650	2	PRIGIONIERO M10X165 MM	STUD BOLT M10X165 MM	GOUJON M10X165 MM	STIFTSCHRAUBE M10X165 MM	ESPARRAGO M10X165 MM

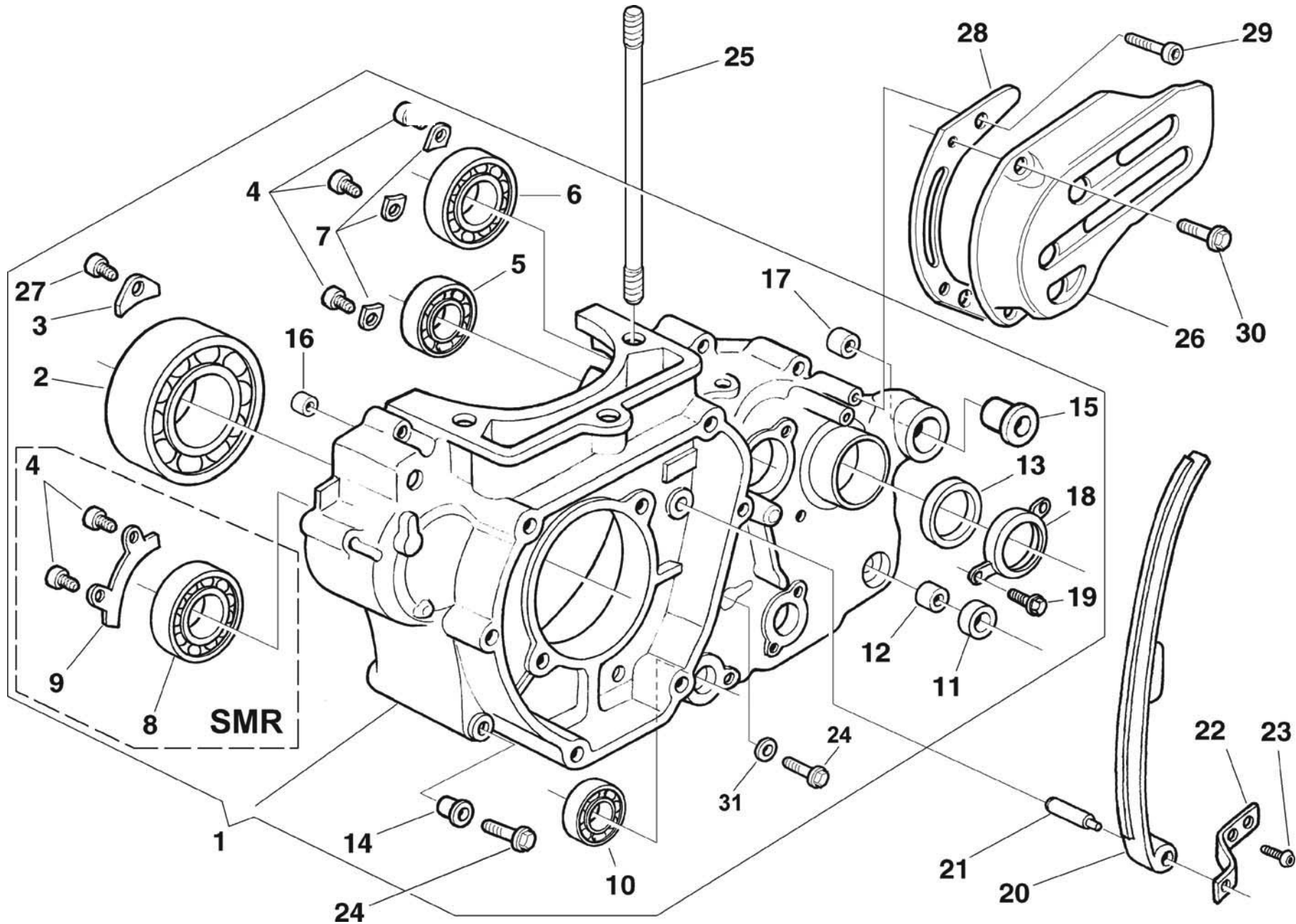



Vedi Tavola 12  
See Drawing 12  
Voir Table 12  
Sehen Bild 12  
Ver Tabla12

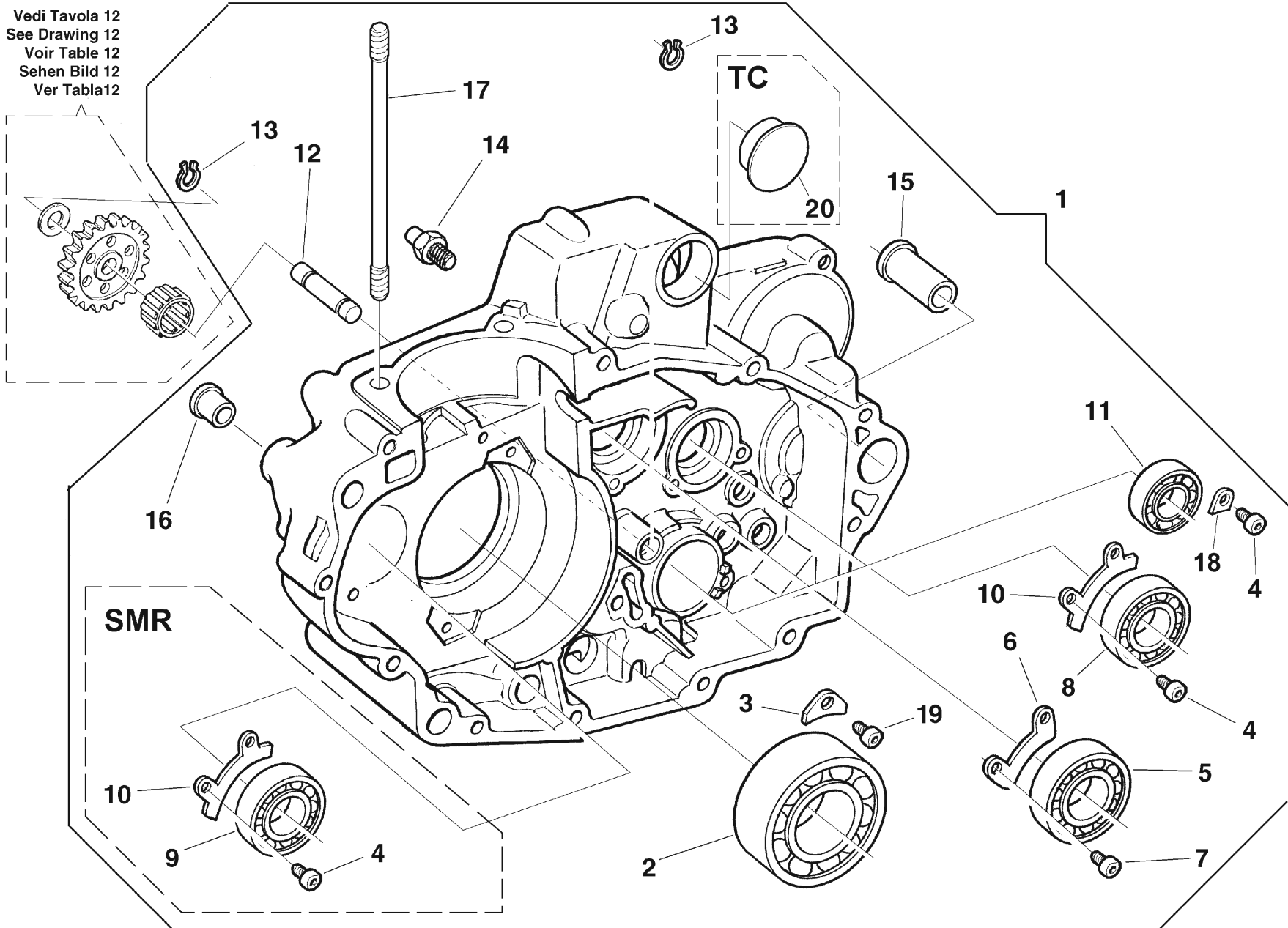



Note Notes Notes Marke Notas	Pos. No. Index Pos.	N. Cod. Code No. Nr. Code Code Nr N. Cod.	Q.tà Q.ty Q.te M.ge C.ad	DENOMINAZIONE	NAME	DESIGNATION	BESHREIBUNG	DENOMINACION
SMR	1	8A00A5671	1	CARTER MOTORE	CRANKCASE SET	CARTER MOTEUR	KURBELWELLENGEHAUSE	CARTER MOTOR
TC 250	1	8A00A6443	1	CARTER MOTORE	CRANKCASE SET	CARTER MOTEUR	KURBELWELLENGEHAUSE	CARTER MOTOR
TC 450-510	1	8A00A6445	1	CARTER MOTORE	CRANKCASE SET	CARTER MOTEUR	KURBELWELLENGEHAUSE	CARTER MOTOR
TE-TXC 250	1	8A00A5603	1	CARTER MOTORE	CRANKCASE SET	CARTER MOTEUR	KURBELWELLENGEHAUSE	CARTER MOTOR
TE-TXC 450-510	1	8A00A7275	1	CARTER MOTORE	CRANKCASE SET	CARTER MOTEUR	KURBELWELLENGEHAUSE	CARTER MOTOR
250	2	8000A2767	1	CUSCINETTO A SFERE 30X62X16 MM	BALL BEARING 30X62X16 MM	ROULEMENT A BILLES 30X62X16 MM	KUGELLAGER 30X62X16 MM	COJINETE DE BOLAS 30X62X16 MM
450-510	2	800099846	1	CUSCINETTO A SFERE 30X72X19 MM	BALL BEARING 30X72X19 MM	ROULEMENT A BILLES 30X72X19 MM	KUGELLAGER 30X72X19 MM	COJINETE DE BOLAS 30X72X19 MM
	3	800097941	2	PIASTRINA RITEGNO CUSCINETTO	RETAINER, BEARING	PLAQUE ARRET ROULEMENT	STOPPLATTE, LAGER	PLACA RETENCION COJINETE
	5	800024952	1	CUSCINETTO A SFERE 6204 PX2 V4	BALL BEARING 6204 PX2 V4	ROULEMENT A BILLES 6204 PX2 V4	KUGELLAGER 6204 PX2 V4	COJINETE DE BOLAS 66204 PX2 V4
	6	8A0042100	1	PIASTRINA	PLATE	PLAQUETTE	PLAETTCHEN	PLETINA
	7	8B0055241	2	VITE TCEI M6X1,00X10 CH5	SCREW TCEI M6X1.00X10 CH5	VIS TCEI M6X1,00X10 CH5	SCHRAUBE TCEI M6X1,00X10 CH5	TORNILLO TCEI M6X1,00X10 CH5
	8	800017040	1	CUSCINETTO A SFERE 20X42X12	BEARING 20X42X12	ROULEMENT A BILLES 20X42X12	KUGELLAGER 20X42X12	COJINETE DE BOLAS 20X42X12
SMR	9	8A0019768	1	CUSCINETTO A SFERE	BEARING, BALL	ROULEMENT A BILLES	KUGELLAGER	COJINETE DE BOLAS
SMR	10	800091602	2	PIASTRINA RITEGNO CUSCINETTO	RETAINER, BEARING	PLAQUE ARRET ROULEMENT	STOPPLATTE, LAGER	PLACA RETENCION COJINETE
TE-TC-TXC	10	800091602	1	PIASTRINA RITEGNO CUSCINETTO	RETAINER, BEARING	PLAQUE ARRET ROULEMENT	STOPPLATTE, LAGER	PLACA RETENCION COJINETE
	11	800085395	1	CUSCINETTO A SFERE 25X42X9	BEARING, BALL 25X42X9	ROULEMENT A BILLES 25X42X9	KUGELLAGER 25X42X9	COJINETE DE BOLAS 25X42X9
	12	8000A5662	1	ASSE INGRANAGGIO	AXLE, GEAR	AXE ENGRENAGE	ACHSE, ZAHNRAD	EJE ENGRANAJE
	13	66N021312	2	ANELLO BENZING 18,5X9X1,1 MM DIN6799	CIRCLIP E-TYPE 18,5X9X1,1 MM DIN6799	BAGUE BENZING 18,5X9X1,1 MM DIN6799	BENZINGRING 18,5X9X1,1 MM DIN6799	ANILLO BENZING 18,5X9X1,1 MM DIN6799
	14	8B0066953	1	PERNO FERMO SELETTORE	PIN	PIVOT	BOLZEN	PERNO
	15	800073500	1	BOCCOLA FORCELLONE	BUSHING, SWING ARM	DOUILLE, BRAS OSCILLANT	HULSE, SCHWINGE	COLLAR BASCULANTE
	16	161077703	2	BOCCOLA FLANGIATA	BUSH WITH COLLAR	DOUILLE BRIDEE	GEFLANSCHBUCHSE	CASQUILLO REBORDEADO

Vedi Tavola 12  
See Drawing 12  
Voir Table 12  
Sehen Bild 12  
Ver Tabla12

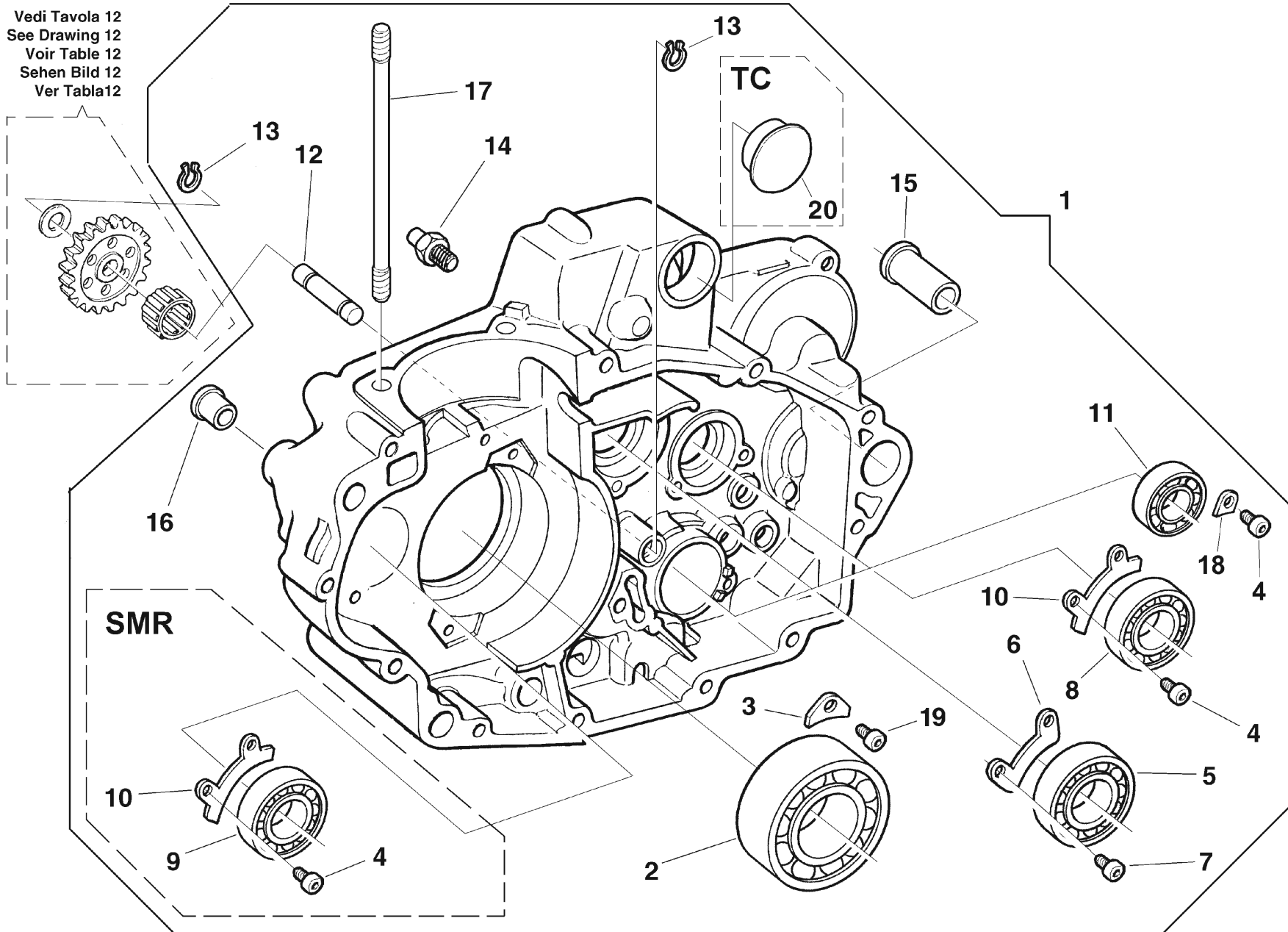



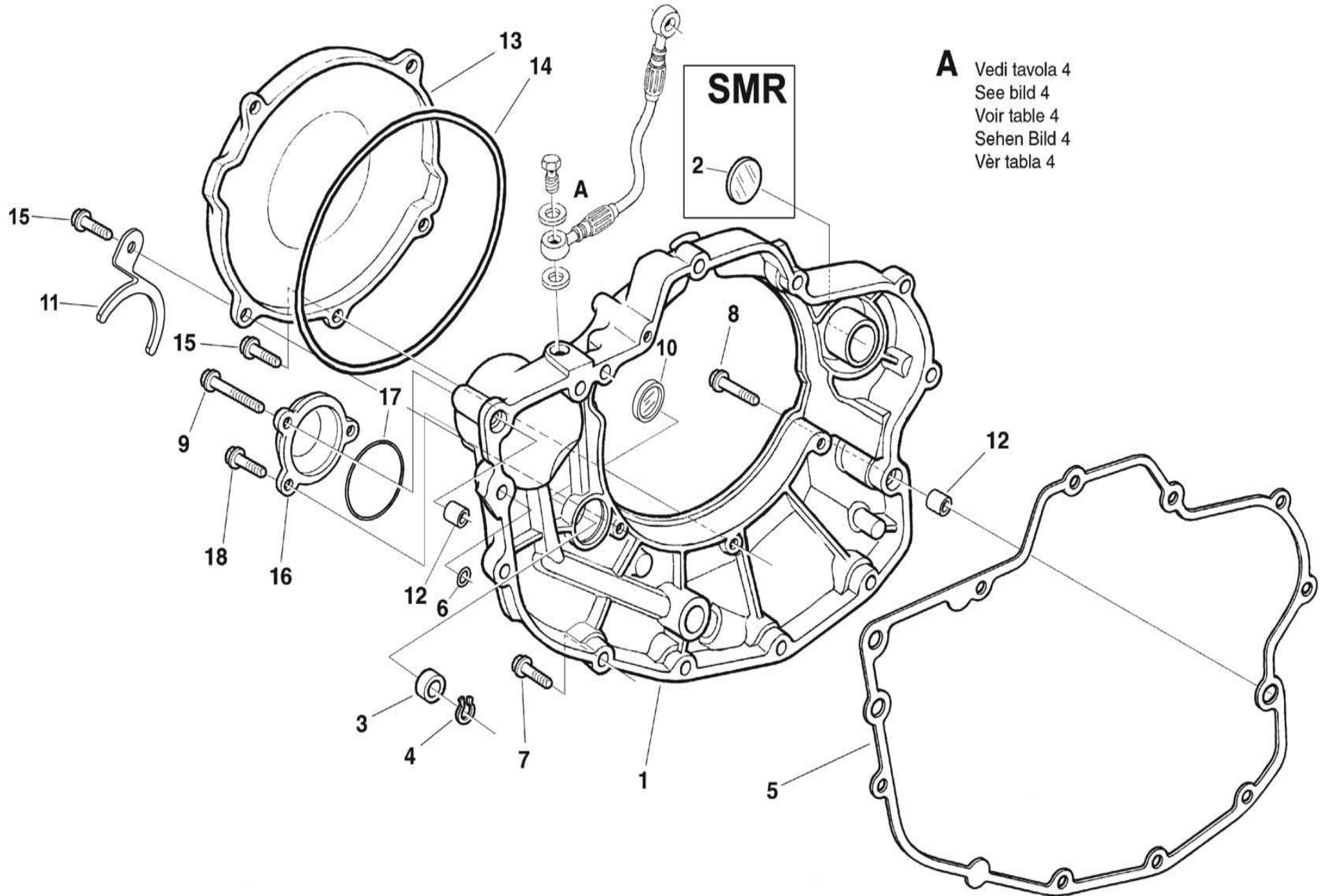

**A** Vedi tavola 4  
See bild 4  
Voir table 4  
Sehen Bild 4  
Vër tabla 4

Note Notes Notes Marke Notas	Pos. No. N. Index Pos.	N. Cod. Code No. Nr. Code Code Nr N. Cod.	Q.tà Q.ty Q.te M.ge C.ad	DENOMINAZIONE	NAME	DESIGNATION	BESHREIBUNG	DENOMINACION
	1	80B0B0388	1	COPERCHIO FRIZIONE	COVER, CLUTCH	COUVERCLE EMBRAYAGE	KUPPLUNGSDECKEL	CUBIERTA EMBRAGUE
SMR	2	8000A0765	1	TAPPO 25MM	PLUG 25MM	BOUCHON 25MM	VERSCHLUSS 25MM	TAPON 25MM
	3	8A0028855	1	PARAOLIO BABSLD 22X12X6,5	OIL SEAL BABSLD 22X12X6.5	BAGUE D'ETANCHEITE BABSLD 22X12X6,5	WELLENDICHTRING BABSLD 22X12X6,5	RETEN DE ACEITE BABSLD 22X12X6,5
	4	66N021258	1	ANELLO ELASTICO 23,5X22X1	SPRING RING 23.5X22X1	BAGUE ELASTIQUE 23,5X22X1	FEDERRING 23,5X22X1	ANILLO ELASTICO 23,5X22X1
	5	8000A5906	1	GUARNIZIONE COPERCHIO FRIZIONE	GASKET, CLUTCH COVER	JOINT COUVERCLE EMBRAYAGE	DICHTUNG KUPPLUNGSDECKEL	JUNTA CUBIERTA EMBRAGUE
	6	800099855	1	ANELLO O-RING 108 6,02X2,62	O-RING 108 6.02X2.62	JOINT TORIQUE 108 6,02X2,62	O-RING 108 6,02X2,62	JUNTA TORICA 108 6,02X2,62
	7	800062729	10	VITE TEF M6X1X25 CH8	SCREW TEF M6X1X25 CH8	VIS TEF M6X1X25 CH8	SCHRAUBE TEF M6X1X25 CH8	TORNILLO TEF M6X1X25 CH8
	8	8A0067545	1	VITE TEF M6X1,00X35 CH8	SCREW TEF M6X1.00X35 CH8	VIS TEF M6X1,00X35 CH8	SCHRAUBE TEF M6X1,00X35 CH8	TORNILLO TEF M6X1,00X35 CH8
	9	8F0067545	1	VITE TE M6X1X80	SCREW TE M6X1X80	VIS TE M6X1X80	SCHRAUBE TE M6X1X80	TORNILLO TE M6X1X80
	10	800073529	1	VETRINO SPIA LIVELLO OLIO	WINDOW, OIL LEVEL CHECK	HUBLOT NIVEAU HUILE	SCHAUGLAS, OELKONTROLL	MIRILLA NIVEL ACEITE
TC 250-450-510	11	8000B1507	1	PIASTRINA	PLATE	PLAQUETTE	PLAETTCHEN	PLETINA
TE-TXC 250	11	8000B1506	1	PIASTRINA	PLATE	PLAQUETTE	PLAETTCHEN	PLETINA
	12	800007719	2	GRANO RIFERIMENTO 10X7,2X16	PIN, DOWEL 10X7.2X16	GOUJON DE REFERENCE 10X7,2X16	BEZUGSSTIFT 10X7,2X16	ESPIGA DE REFERENCIA 10X7,2X16
TC 250-450-510	13	80A0A5934	1	COPERCHIO FRIZIONE ESTERNO	CLUTCH COVER, OUTER	COUVERCLE EMBRAYAGE EXTERIEUR	AUSSEREKUPPLUNGSDECKEL	CUBIERTA EMBRAGUE EXTERIOR
TXC-TE 250	13	80A0A5931	1	COPERCHIO FRIZIONE ESTERNO	CLUTCH COVER, OUTER	COUVERCLE EMBRAYAGE EXTERIEUR	AUSSEREKUPPLUNGSDECKEL	CUBIERTA EMBRAGUE EXTERIOR
	14	800086878	1	ANELLO O-RING 165X2,62	O-RING 165X2.62	JOINT TORIQUE 165X2,62	O-RING 165X2,62	JUNTA TORICA 165X2,62
250	15	800062728	5	VITE TEF M6X1X20 CH8	SCREW TEF M6X1X20 CH8	VIS TEF M6X1X20 CH8	SCHRAUBE TEF M6X1X20 CH8	TORNILLO TEF M6X1X20 CH8
450-510	15	800062730	5	VITE TE M6X1X30 CH8	SCREW TE M6X1X30 CH8	VIS TE M6X1X30 CH8	SCHRAUBE TE M6X1X30 CH8	TORNILLO TE M6X1X30 CH8
	16	80B091551	1	COPERCHIO FILTRO OLIO	COVER, OIL ELEMENT	COUVERCLE FILTRE A HUILE	DECKEL, OELFILTER	CUBIERTA FILTRO ACEITE
	17	8A0028553	1	ANELLO O-RING 3200	O-RING 3200	JOINT TORIQUE 3200	O-RING 3200	JUNTA TORICA 3200
	18	800062728	2	VITE TEF M6X1X20 CH8	SCREW TEF M6X1X20 CH8	VIS TEF M6X1X20 CH8	SCHRAUBE TEF M6X1X20 CH8	TORNILLO TEF M6X1X20 CH8

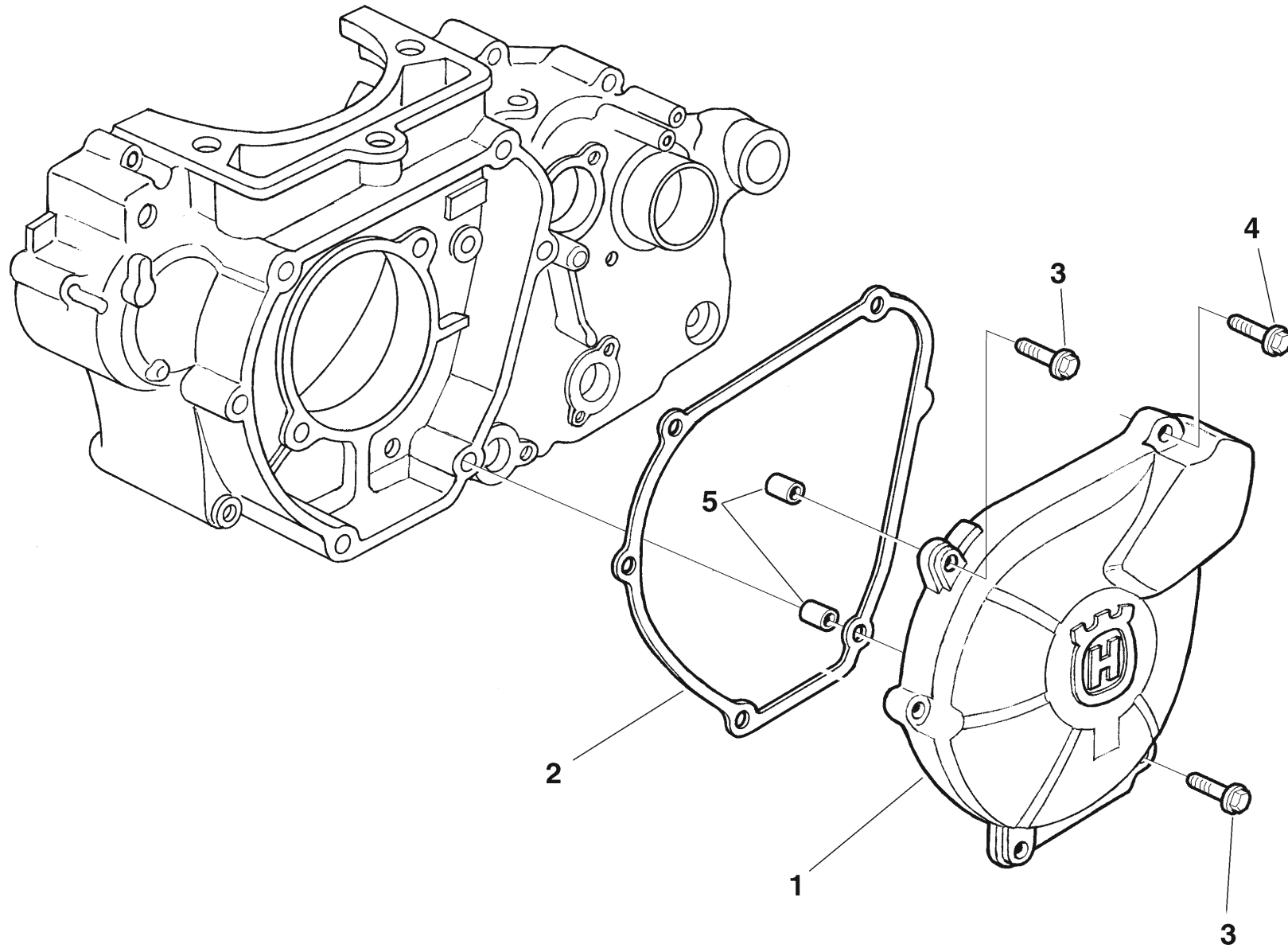



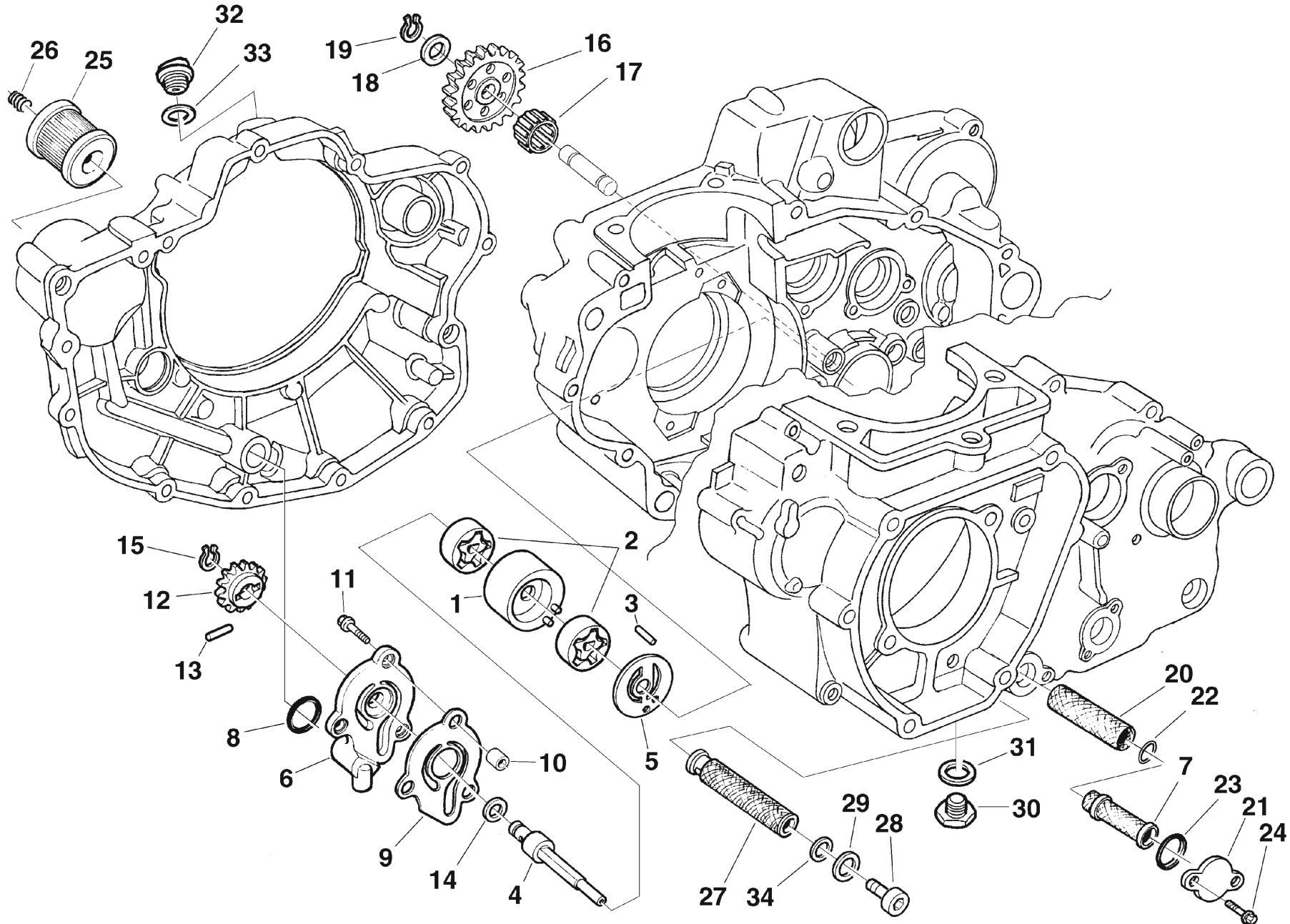



Note Notes Notes Marke Notas	Pos. No. N. Index Pos.	N. Cod. Code No. Nr. Code Code Nr N. Cod.	Q.tà Q.ty Q.te M.ge C.ad	DENOMINAZIONE	NAME	DESIGNATION	BESHREIBUNG	DENOMINACION
	1	800099858	1	CORPO POMPA OLIO	HOUSING, OIL PUMP	CORPS POMPE A HUILE	OELPUMPEGEHAEUSE	CUERPO BOMBA ACEITE
	2	800082948	2	TROCOIDE ASPIRAZIONE OLIO	OIL SUCTION ROTOR	ROTOR ASPIRATEUR HUILE	OELSAUGROTOR	ROTOR ADMISION ACEITE
	3	8A0047773	2	RULLINO	ROLLER	ROULEAU	ROLLE	RODILLO
	4	800099860	1	ALBERO POMPA OLIO	SHAFT, OIL PUMP	ARBRE POMPE A HUILE	WELLE, OELPUMPE	ARBOL, BOMBA ACEITE
	5	800099861	1	DISTANZIALE ROTORE POMPA OLIO	SPACER, OIL PUMP ROTOR	ENTRETOISE ROTOR POMPE A HUILE	ABSTANDHALTER, ROTOR OELPUMPE	DISTANCIADOR ROTOR BOMBA ACEITE
	6	800091552	1	COPERCHIO POMPA OLIO	COVER OIL PUMP	COUVERCLE POMPE HUILE	OELPUMPENDECKEL	CUBIERTA BOMBA ACEITE
	7	800072427	1	FILTRO OLIO INTERNO	OIL FILTER, INNER	FILTRE A HUILE INTERIEUR	OELFILTER, INNEN	FILTRO ACEITE INTERIOR
	8	800025082	1	ANELLO O-RING 3056 13,95X2,62	O-RING 13.95X2.62	JOINT TORIQUE 13,95X2,62	O-RING 13,95X2,62	JUNTA TORICA 13,95X2,62
	9	800099862	1	COPERCHIO INTERMEDIO POMPA	COVER	COUVERCLE	DECKEL	CUBIERTA
	10	161795502	2	GRANO RIFERIMENTO 8X6,4X10	PIN DOWEL 8X6.4X10	GOUJON, D'ASSEMBLAGE 8X6,4X10	BEZUGSSTIFT 8X6,4X10	PASADOR ESPIGA DE REFERENCIA 8X6,4X10
	11	800062728	3	VITE TEF M6X1X20 CH8	SCREW TEF M6X1X20 CH8	VIS TEF M6X1X20 CH8	SCHRAUBE TEF M6X1X20 CH8	TORNILLO TEF M6X1X20 CH8
	12	800099863	1	INGRANAGGIO CONDOTTO POMPA Z11	GEAR, PUMP DRIVEN T11	ENGRANAGE ENTRAINE PUMPE D11	ANTRIEBSRAD Z11	ENGRANAJE ACCIONADO BOMBA D11
	13	800047773	1	RULLINO	ROLLER	ROULEAU	ROLLE	RODILLO
	14	8E0034292	1	RONDELLA 14X8,2	WASHER 14X8.2	RONDELLE 14X8,2	SCHEIBE 14X8,2	ARANDELA 14X8,2
	15	800021375	1	ANELLO SEEGER 8MM DIN 471	CIRCLIP 8MM DIN 471	CIRCLIP 8MM DIN 471	SEEGERRING 8MM DIN 471	ANILLO ELASTICO 8MM DIN 471
	16	800099864	1	INGRANAGGIO INTERMEDIO POMPA Z24	IDLE GEAR T24	PIGNON INTERMEDIAIRE D24	FREILAUFRAD Z24	ENGRANAJE INTERMEDIO D24
	17	800033718	1	ASTUCCIO A RULLI HK1210	BEARING, NEEDLE HK1210	ROULEMENT A AIGUILLES HK1210	NADELLAGER HK1210	COJINETE DE AGUJAS HK1210
	18	8A0001261	1	RONDELLA 19X12X0,3	WASHER 19X12X0.3	RONDELLE 19X12X0,3	SCHEIBE 19X12X0,3	ARANDELA 19X12X0,3
	19	66N021202	1	ANELLO SEEGER 12MM	CIRCLIP 12MM	CIRCLIP 12MM	SPRENGRING 12MM	ANILLO SEEGER 12MM
	20	800072426	1	FILTRO OLIO ESTERNO	OIL FILTER, OUTER	FILTRE A HUILE EXTERIEUR	OELFILTER, AUSSER	FILTRO ACEITE EXTERIOR
	21	800072425	1	COPERCHIO FILTRO OLIO	COVER, OIL ELEMENT	COUVERCLE FILTRE A HUILE	DECKEL, OELFILTER	CUBIERTA FILTRO ACEITE
	22	800026884	1	ANELLO O-RING 15,54X2,62	O-RING 3062 15.54X2.62	JOINT TORIQUE 3062 15,54X2,62	O-RING 3062 15,54X2,62	JUNTA TORICA 3062 15,54X2,62
	23	800034609	1	ANELLO O-RING 3087 22X2,62	O-RING 3087 22X2.62	JOINT TORIQUE 3087 22X2,62	O-RING 3087 22X2,62	JUNTA TORICA 3087 22X2,62
	24	800066525	2	VITE TEF M5X0,8X12	SCREW TEF M5X0.8X12	VIS TEF M5X0,8X12	SCHRAUBE TEF M5X0,8X12	TORNILLO TEF M5X0,8X12
	25	8000B0593	1	FILTRO OLIO	FILTER, OIL	FILTRE A HUILE	OELFILTER	FILTRO ACEITE
	26	800099866	1	MOLLA FILTRO OLIO	SPRING, OIL FILTER	RESSORT FILTRE A HUILE	FEDER, OELFILTER	RESORTE, FILTRO ACEITE
	27	8A0074716	1	FILTRO OLIO ASPIRAZIONE	STRAINER, OIL	CREPINE HUILE	OLNETZ	REDECILLA ACEITE
	28	800099711	1	TAPPO DIN 908 M14X1,5	PLUG DIN 908 M14X1.5	BOUCHON DIN 908 M14X1,5	VERSCHLUSS DIN 908 M14X1,5	TAPON DIN 908 M14X1,5
	29	62N015678	1	RONDELLA IN ALLUMINIO 21X14,3X1,2	WASHER, ALUMINIUM 21X14.3X1.2	RONDELLE EN ALUMINIUM 21X14,3X1,2	ALUMINIUM SCHEIBE 21X14,3X1,2	ARANDELA ALUMINIO 21X14,3X1,2
	30	800073011	1	TAPPO DRENAGGIO OLIO	PLUG, OIL DRAIN	BOUCHON VIDANGE HUILE	VERSCHLUSS, OELABLASS	TAPON PURGA ACEITE
	31	62N015679	1	RONDELLA IN ALLUMINIO 24X16,3	ALUMINIUM WASHER 24X16.3	RONDELLE EN ALUMINIUM 24X16,3	ALUMINIUM SCHEIBE 24X16,3	ARANDELA DE ALUMINIO 24X16,3
	32	800036786	1	TAPPO ALIMENTAZIONE OLIO	CAP, OIL FILLER	BOUCHON REMPLISSEMENT HUILE	STOEPSSEL OELINFUELL	TAPON INTRUDUCCION ACEITE
	33	800029171	1	ANELLO O-RING 123 2,65X17,86 MM	O-RING 123 2.65X17.86 MM	JOINT TORIQUE 123 2,65X17,86 MM	O-RING 123 2,65X17,86 MM	JUNTA TORICA 123 2,65X17,86 MM

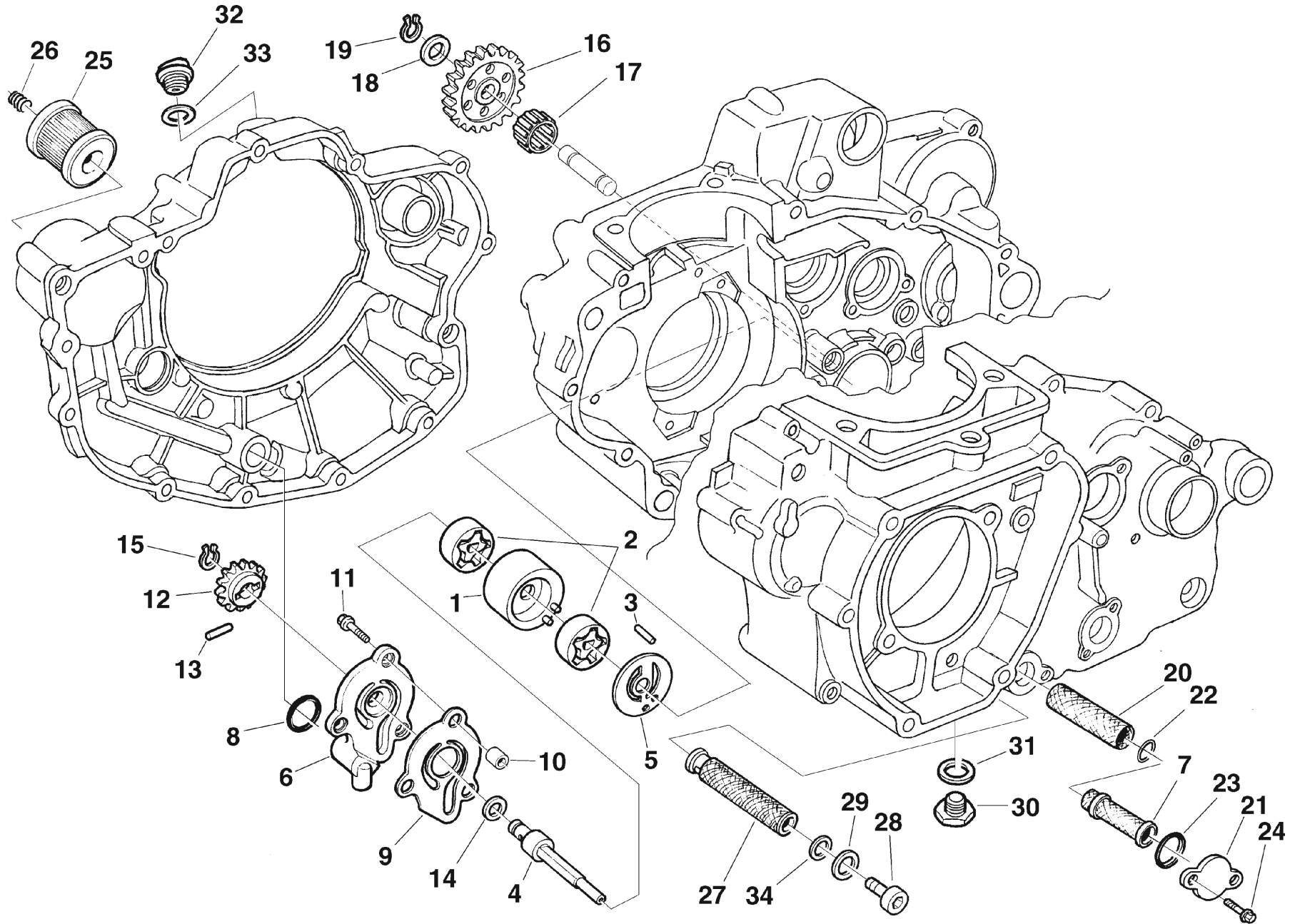



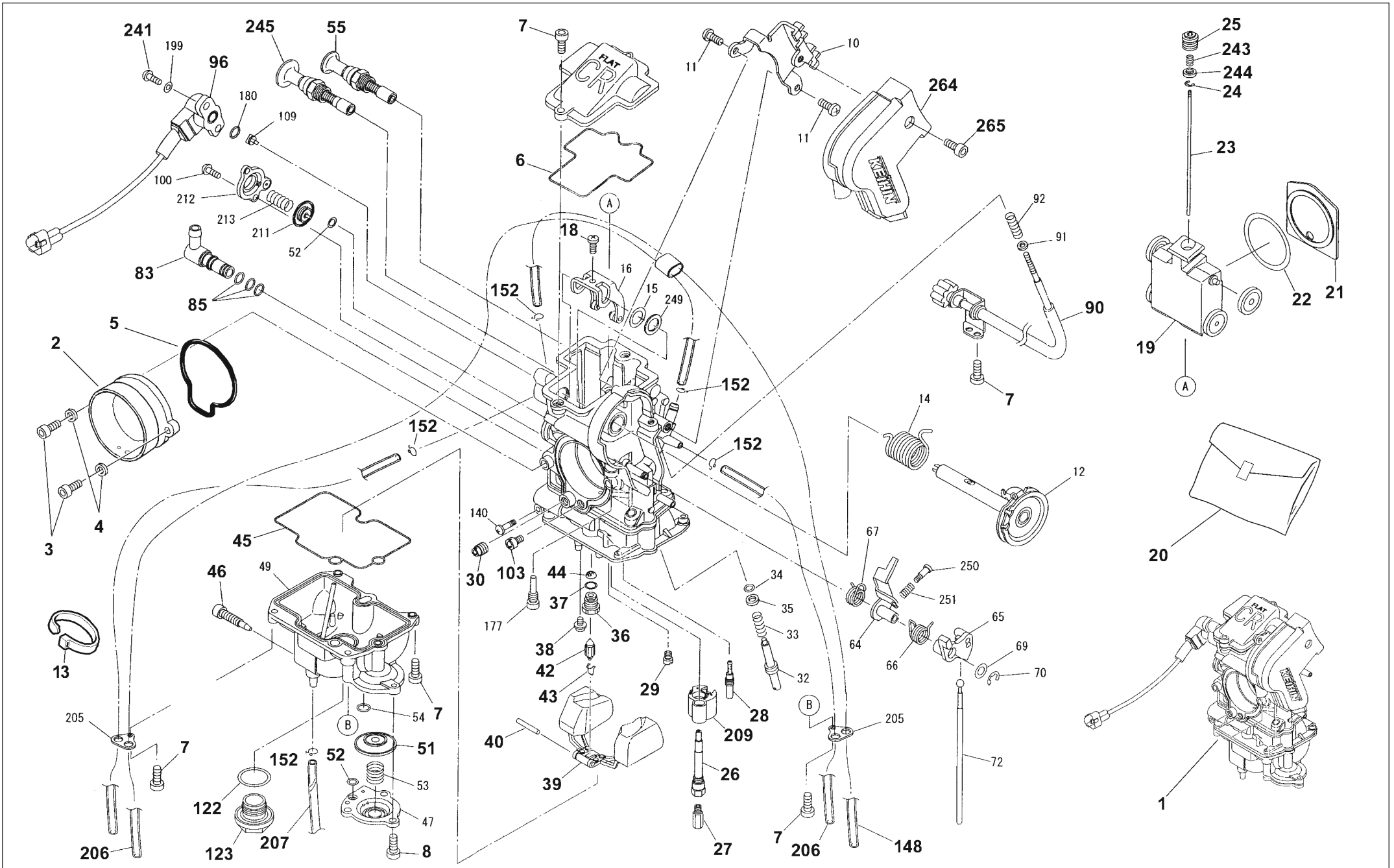

Note Notes Notas	Pos. No. N. Index Pos.	N. Cod. Code No. Nr. Code Code Nr N. Cod.	Q.tà Q.ty Q.te M.ge C.ad	DENOMINAZIONE	NAME	DESIGNATION	BESHREIBUNG	DENOMINACION
TC-TXC 250	1	8000A8073	1	CARBURATORE KEIHIN 37	CARBURETOR KEIHIN 37	CARBURATEUR KEIHIN 37	VERGASER KEIHIN 37	CARBURADOR KEIHIN 37
TC-TXC 450-510	1	8000A8074	1	CARBURATORE	CARBURETOR	CARBURATEUR	VERGASER	CARBURADOR
	2	8000A2987	1	CORNETTO PRESARIA	AIR FUNNEL	TUBE VENTURI PRISE AIR	LUFTEINLASSHORN VENTURI	TROMPETA ADMISION
	3	60N102482	2	VITE TCEI M5X0,8X10	SCREW TCEI M5X0.8X10	VIS TCEI M5X0,8X10	SCHRAUBE TCEI M5X0,8X10	TORNILLO TCEI M5X0,8X10
	4	800036137	2	RONDELLA 11X5,5X1,5	WASHER 11X5.5X1.5	RONDELLE 11X5,5X1,5	SCHEIBE 11X5,5X1,5	ARANDELA 11X5,5X1,5
	5	800098215	1	ANELLO O-RING 2033 50,52X1,78 MM	O-RING 2033 50.52X1.78 MM	JOINT TORIQUE 2033 50,52X1,78 MM	O-RING 2033 50,52X1,78 MM	JUNTA TORICA 2033 50,52X1,78 MM
	6	8000A5616	1	ANELLO O-RING	O-RING	JOINT TORIQUE	O-RING	JUNTA TORICA
	7	8A00A5617	6	VITE	SCREW	VIS	SCHRAUBE	TORNILLO
	8	8000A5617	3	VITE	SCREW	VIS	SCHRAUBE	TORNILLO
	13	800056444	2	FASCETTA 188 MM	CLAMP 188 MM	COLLIER 188 MM	SHELLE 188 MM	ABRAZADERA 188 MM
	18	8000A5618	1	VITE	SCREW	VIS	SCHRAUBE	TORNILLO
	19	8000A5619	1	VALVOLA GAS 15/M	THROTTLE VALVE 15/M	PAPILLON DE GAZ 15/M	DROSSELKLAPPE 15/M	VALVULA 15/M
TC-TXC 250	20	8000A4295	1	GRUPPO REVISIONE CARBURATORE	CARBURETOR OVERHAUL SET	GROUPE REVISION CARBURATEUR	VERGASER EBERHOLUNGSSATZ	GRUPO REVISION CARBURADOR
TC-TXC 450-510	20	8000A4296	1	GRUPPO REVISIONE CARBURATORE	CARBURETOR OVERHAUL SET	GROUPE REVISION CARBURATEUR	VERGASER EBERHOLUNGSSATZ	GRUPO REVISION CARBURADOR
	21	8000A5620	1	SEDE GUARNIZIONE	FLOATING VALVE	SIEGE GARNITURE	DICHTUNG SITZRING	ALOJAMIENTO JUNTA
	22	8000A5621	1	GUARNIZIONE	GASKET	JOINT	DICHTUNG	JUNTA
	23	800098196	1	SPILLO CONICO OBDRV	NEEDLE JET OBDRV	POINTEAU CONIQUE OBDRV	KEGELNADEL OBDRV	AGUJA CONICA OBDRV
	24	8000A5622	1	ANELLO SEEGER	CIRCLIP	CIRCLIP	SEEGERRING	ANILLO SEEGER
	25	8000A5623	1	VITE SPILLO CONICO	SCREW NEEDLE SET	VIS POINTEAU CONIQUE	SCHRAUBE KEGEL NADEL	TORNILLO POR PASADOR CONICO
	26	8000A5624	1	POLVERIZZATORE P4	JET, NEEDLE P4	PULVERISATEUR P4	ZESTAEUBER P4	ATOMIZADOR P4
TC-TXC 250	27	8D0098186	1	GETTO MASSIMO 175	JET, MAIN 175	GICLEUR PRINCIPAL 175	HAUPTDUESE 175	CHICLE' PRINCIPAL 175
TC-TXC 450-510	27	8A0098186	1	GETTO MASSIMO 180	JET, MAIN 180	GICLEUR PRINCIPAL 180	HAUPTDUESE 180	CHICLE' PRINCIPAL 180
TC-TXC 250	28	8000A4624	1	GETTO MINIMO 42	JET, PILOT 42	GICLEUR RALENTI 42	LEERLAUFDUESE 42	CHICLE' RALENTI 42
TC-TXC 450-510	28	8B00A4624	1	GETTO MINIMO 45	JET, PILOT 45	GICLEUR RALENTI 45	LEERLAUFDUESE 45	CHICLE' RALENTI 45
TC-TXC 250	29	8A0098275	1	GETTO STARTER 72	STARTER JET 72	GICLEUR STARTER 72	STARTERDUESE 72	CHICLE' STARTER 72
TC-TXC 450-510	29	800098275	1	GETTO STARTER 85	STARTER JET 85	GICLEUR STARTER 85	STARTERDUESE 85	CHICLE' STARTER 85
	30	800098268	1	GETTO ARIA MINIMO 100	JET, IDLING AIR 100	GICLEUR AIR RALENTI 100	LEERLAUFLUFTDUESE 100	CHICLE' AIRE RALENTI 100
	36	800098272	1	SEDE VALVOLA A SPILLO	NEEDLE SEAT	SIEGE POINTEAU CONIQUE	KONISCHNADELSITZ	ASIENTO PASADOR
	37	8000A5625	1	ANELLO O-RING	O-RING	JOINT TORIQUE	O-RING	JUNTA TORICA
	38	8000A5626	1	VITE	SCREW	VIS	SCHRAUBE	TORNILLO
	39	8000A5627	1	GALLEGGIANTE	FLOAT	FLOTTEUR	SCHWIMMER	FLOTADOR
	40	8000A5628	1	PERNO GALLEGGIANTE	PIN, FLOAT	AXE, FLOTTEUR	STIFT, SCHWIMMER	PASADOR LA BOYA
	42	8000A5629	1	VALVOLA A SPILLO	JET, NEEDLE	SOUPAPE A POINTEAU	NADELVENTIL	VALVULA FLOTADOR

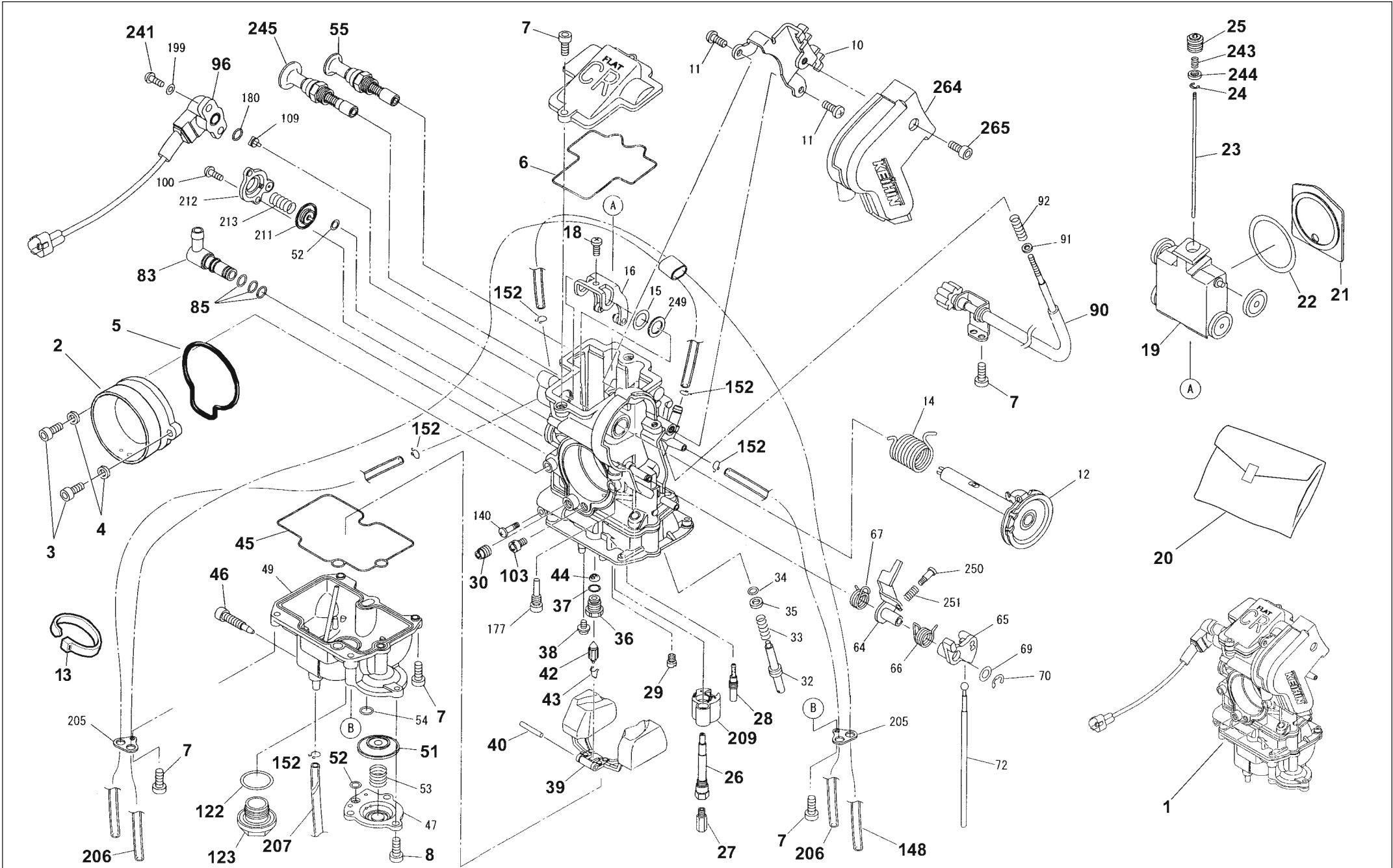

Note Notes Notes Marke Notas	Pos. No. N. Index Pos.	N. Cod. Code No. Nr. Code Code Nr N. Cod.	Q.tà Q.ty Q.te M.ge C.ad	DENOMINAZIONE	NAME	DESIGNATION	BESHREIBUNG	DENOMINACION
	43	8000A5630	1	MOLLA VALVOLA A SPILLO	CLIP, NEEDLE VALVE	RESSORT	FEDER	RESORTE
	44	8000A5631	1	FILTRO	FILTER	FILTRE	FILTER	FILTRO
	45	8000A5632	1	ANELLO O-RING	O-RING	JOINT TORIQUE	O-RING	JUNTA TORICA
	46	8000A5633	1	VITE SPURGO	SCREW, BLEED	VIS VIDANGE	SCHRAUBE, ABLASS	TORNILLO PURGA
TC-TXC 250	51	8000A5634	1	DIAFRAMMA	DIAPHRAGM	DIAPHRAGME	MEMBRAN	MEMBRANA
TC-TXC 450-510	51	8A00A5634	1	DIAFRAMMA	DIAPHRAGM	DIAPHRAGME	MEMBRAN	MEMBRANA
	52	8000A5635	1	ANELLO O-RING	O-RING	JOINT TORIQUE	O-RING	JUNTA TORICA
	55	8000A5636	1	DISPOSITIVO STARTER A FREDDO	PLUNGER STARTER COOL	ENSEMBLE DEMARREUR, FROID	KUEHLSTART, SATZ	JUEGO ARRANQUE, EN FRIO
	83	8000A5637	1	RACCORDO SINISTRO	L JOINT COMP.	RACCORD	ANSCHLUSS	EMPALME
	85	8000A5638	1	ANELLO O-RING	O-RING	JOINT TORIQUE	O-RING	JUNTA TORICA
	90	8000A5639	1	VITE REGOLAZIONE MINIMO	SCREW, PILOT ADJUSTING	VIS, REGLAGE RALENTI	DROSSELSCHRAUBEN	TORNILLO AJUSTE PILOTO
	96	8000A5640	1	SENSORE POSIZIONE VALVOLA GAS	SENSOR, THROTTLE	CAPTEUR PAPILLON GAZ	ABTASTER, VERGASERKOLBEN	SENSOR VALVULA REGULADORA
	103	800098250	1	GETTO ARIA MASSIMO 200	JET, MAIN AIR 200	GICLEUR AIR PRINCIPAL 200	LUFTHAUPTDUESE 200	CHICLE' AIRE PRINCIPAL 200
	122	8000A5641	1	ANELLO O-RING	O-RING	JOINT TORIQUE	O-RING	JUNTA TORICA
	123	8000A5642	1	TAPPO VASCHETTA GALLEGGIANTE	PLUG, FLOAT CHAMBER	BOUCHON CUVETTE FLOTTEUR	PROPFEN, SCHWIMMERGEHAEUSE	TAPON CUBETA FLOTADOR
	148	8000A5643	1	TUBO VENTILAZIONE	VENTILATION HOSE	TUYAU VENTILATION	LUFTUNGSSCHLAUCH	MANGUERA VENTILACION
	152	8000A5644	1	MOLLETTA	SPRING	RESSORT	FEDER	MUELLE
	206	8000A5645	2	TUBO VENTILAZIONE	VENTILATION HOSE	TUYAU VENTILATION	LUFTUNGSSCHLAUCH	MANGUERA VENTILACION
	207	8000A5646	1	TUBO VENTILAZIONE	VENTILATION HOSE	TUYAU VENTILATION	LUFTUNGSSCHLAUCH	MANGUERA VENTILACION
	209	8000A5647	1	PORTAGETTO	HOLDER, JET	PORTE GLICEUR	DUESETRAEGER	SOPORTE CHICLE'
	241	8000A5648	2	VITE	SCREW	VIS	SCHRAUBE	TORNILLO
	243	8000A6113	1	MOLLA	SPRING	RESSORT	FEDER	MUELLE
	244	8000A5650	1	RONDELLA	WASHER	RONDELLE	SCHEIBE	ARANDELA
	245	8000A5651	1	DISPOSITIVO STARTER A CALDO	START SET, HOT	ENSEMBLE DEMARREUR, CHAUD	WARMSTART, SATZ	JUEGO ARRANQUE, EN CALIENTE
	264	8000A5652	1	COPERCHIO	COVER	COUVERCLE	DECKEL	CUBIERTA
	265	8000A5653	1	VITE	SCREW	VIS	SCHRAUBE	TORNILLO

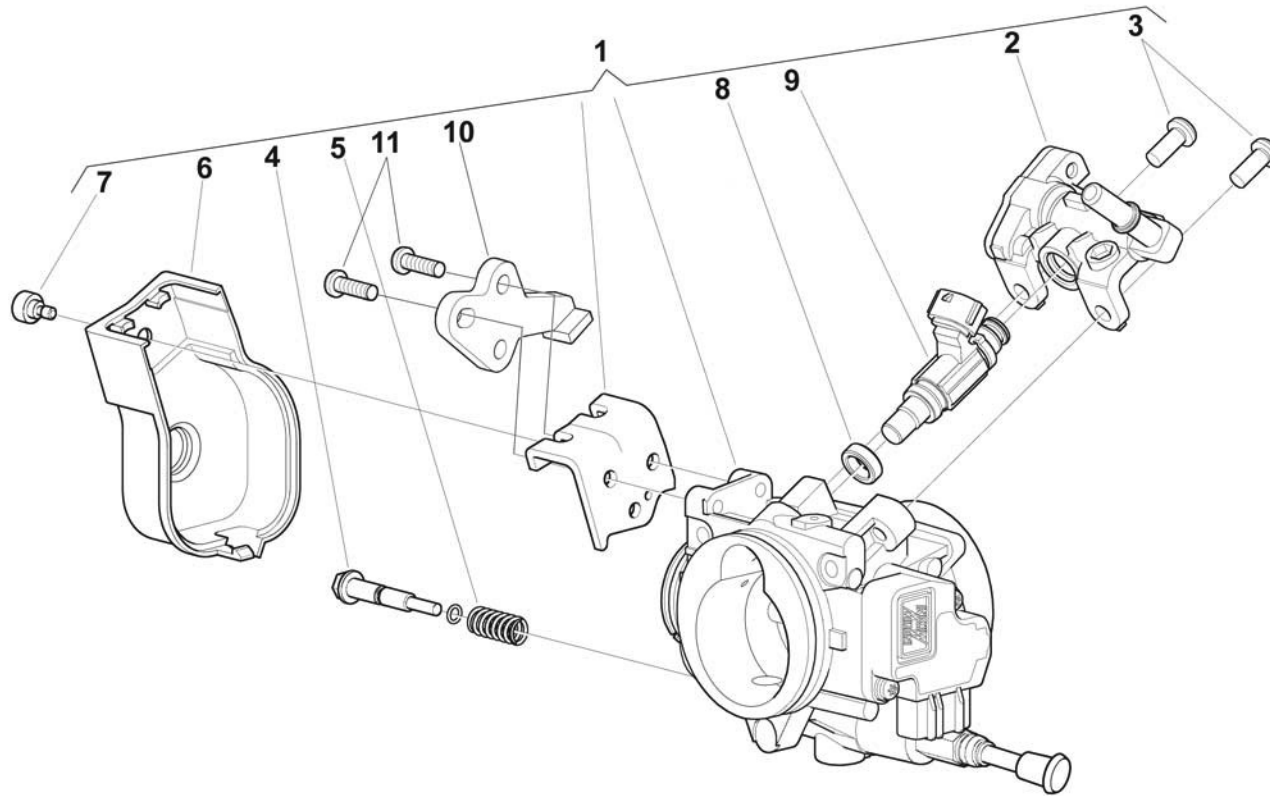





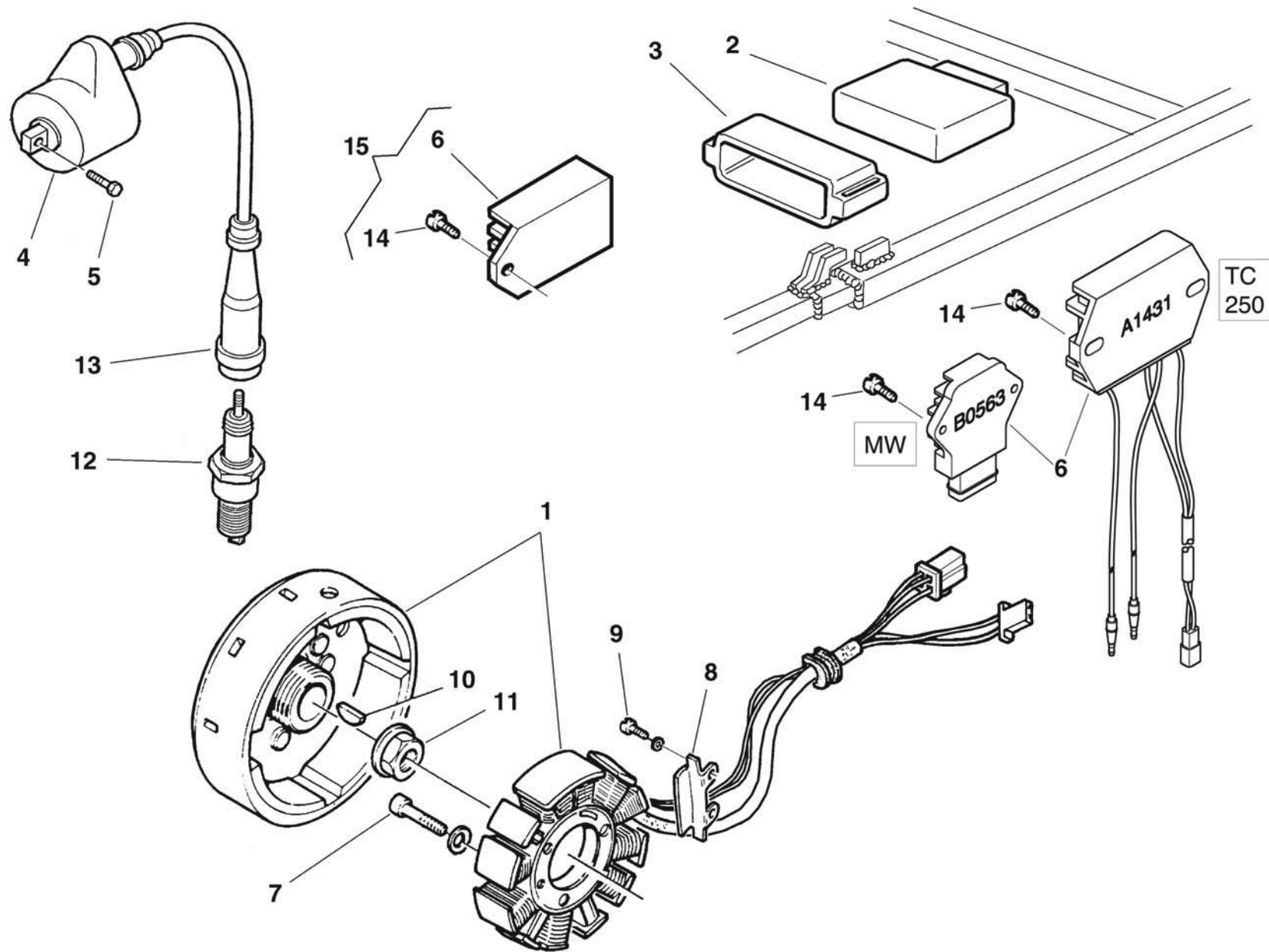

Note Notes Marke Notas	Pos. No. N. Index Pos.	N. Cod. Code No. Nr. Code Code Nr N. Cod.	Q.tà Q.ty Q.te M.ge C.ad	DENOMINAZIONE	NAME	DESIGNATION	BESHREIBUNG	DENOMINACION
TC 250	1	8000A4266	1	GENERATORE	GENERATOR	GENERATEUR	STROMGENERATOR	GENERADOR
TC 450-510	1	8000A4265	1	GENERATORE	GENERATOR	GENERATEUR	STROMGENERATOR	GENERADOR
TE-SMR	1	8000A6737	1	GENERATORE	GENERATOR	GENERATEUR	STROMGENERATOR	GENERADOR
TXC 250	1	8000A4245	1	GENERATORE	GENERATOR	GENERATEUR	STROMGENERATOR	GENERADOR
TXC 450-510	1	8000A4257	1	GENERATORE	GENERATOR	GENERATEUR	STROMGENERATOR	GENERADOR
TC-TXC 250	2	8000A4044	1	CENTRALINA INIEZIONE	CDI UNIT	CENTRALE CONTROLE CDI	STEUERGERAET CDI	CENTRALITA CDI
TC-TXC 450-510	2	8000A4052	1	CENTRALINA INIEZIONE	CDI UNIT	CENTRALE CONTROLE CDI	STEUERGERAET CDI	CENTRALITA CDI
TE510 EUR	2	8S00B0565	1	CENTRALINA INIEZIONE	ENGINE CONTROL UNIT	UNITE' CONTROLE INJECTION	EINSPRITZUNG ZENTRALANLAGE	CENTRAL INYECCION
TE510 USA	2	8U00B0565	1	CENTRALINA INIEZIONE	ENGINE CONTROL UNIT	UNITE' CONTROLE INJECTION	EINSPRITZUNG ZENTRALANLAGE	CENTRAL INYECCION
TE510 AUS	2	8W00B0565	1	CENTRALINA INIEZIONE	ENGINE CONTROL UNIT	UNITE' CONTROLE INJECTION	EINSPRITZUNG ZENTRALANLAGE	CENTRAL INYECCION
TE510 JPN	2	8Y00B0565	1	CENTRALINA INIEZIONE	ENGINE CONTROL UNIT	UNITE' CONTROLE INJECTION	EINSPRITZUNG ZENTRALANLAGE	CENTRAL INYECCION
TE450 EUR	2	8H00B0565	1	CENTRALINA INIEZIONE	ENGINE CONTROL UNIT	UNITE' CONTROLE INJECTION	EINSPRITZUNG ZENTRALANLAGE	CENTRAL INYECCION
TE450 USA	2	8K00B0565	1	CENTRALINA INIEZIONE	ENGINE CONTROL UNIT	UNITE' CONTROLE INJECTION	EINSPRITZUNG ZENTRALANLAGE	CENTRAL INYECCION
TE450 AUS	2	8M00B0565	1	CENTRALINA INIEZIONE	ENGINE CONTROL UNIT	UNITE' CONTROLE INJECTION	EINSPRITZUNG ZENTRALANLAGE	CENTRAL INYECCION
TE450 JPN	2	8P00B0565	1	CENTRALINA INIEZIONE	ENGINE CONTROL UNIT	UNITE' CONTROLE INJECTION	EINSPRITZUNG ZENTRALANLAGE	CENTRAL INYECCION
TE250 EUR	2	8000B0565	1	CENTRALINA INIEZIONE	ENGINE CONTROL UNIT	UNITE' CONTROLE INJECTION	EINSPRITZUNG ZENTRALANLAGE	CENTRAL INYECCION
TE250 USA	2	8B00B0565	1	CENTRALINA INIEZIONE	ENGINE CONTROL UNIT	UNITE' CONTROLE INJECTION	EINSPRITZUNG ZENTRALANLAGE	CENTRAL INYECCION
TE250 AUS	2	8D00B0565	1	CENTRALINA INIEZIONE	ENGINE CONTROL UNIT	UNITE' CONTROLE INJECTION	EINSPRITZUNG ZENTRALANLAGE	CENTRAL INYECCION
TE250 JPN	2	8F00B0565	1	CENTRALINA INIEZIONE	ENGINE CONTROL UNIT	UNITE' CONTROLE INJECTION	EINSPRITZUNG ZENTRALANLAGE	CENTRAL INYECCION
SMR450 EUR	2	8H00B0576	1	CENTRALINA INIEZIONE	ENGINE CONTROL UNIT	UNITE' CONTROLE INJECTION	EINSPRITZUNG ZENTRALANLAGE	CENTRAL INYECCION
SMR450 USA	2	8K00B0576	1	CENTRALINA INIEZIONE	ENGINE CONTROL UNIT	UNITE' CONTROLE INJECTION	EINSPRITZUNG ZENTRALANLAGE	CENTRAL INYECCION
SMR450 AUS	2	8M00B0576	1	CENTRALINA INIEZIONE	ENGINE CONTROL UNIT	UNITE' CONTROLE INJECTION	EINSPRITZUNG ZENTRALANLAGE	CENTRAL INYECCION
SMR450 JPN	2	8P00B0576	1	CENTRALINA INIEZIONE	ENGINE CONTROL UNIT	UNITE' CONTROLE INJECTION	EINSPRITZUNG ZENTRALANLAGE	CENTRAL INYECCION
SMR510 EUR	2	8S00B0576	1	CENTRALINA INIEZIONE	ENGINE CONTROL UNIT	UNITE' CONTROLE INJECTION	EINSPRITZUNG ZENTRALANLAGE	CENTRAL INYECCION
SMR510 USA	2	8U00B0576	1	CENTRALINA INIEZIONE	ENGINE CONTROL UNIT	UNITE' CONTROLE INJECTION	EINSPRITZUNG ZENTRALANLAGE	CENTRAL INYECCION
SMR510 AUS	2	8W00B0576	1	CENTRALINA INIEZIONE	ENGINE CONTROL UNIT	UNITE' CONTROLE INJECTION	EINSPRITZUNG ZENTRALANLAGE	CENTRAL INYECCION
SMR510 JPN	2	8Y00B0576	1	CENTRALINA INIEZIONE	ENGINE CONTROL UNIT	UNITE' CONTROLE INJECTION	EINSPRITZUNG ZENTRALANLAGE	CENTRAL INYECCION
TC-TXC	3	8000A8935	1	SUPPORTO ELASTICO CENTRALINA CDI	CUSHION, C.D.I. UNIT	SUPPORT ELASTIQUE UNITE C.D.I.	SCHWINGSDAEMPFER, C.D.I. EINHEIT	SOPORTE ELASTICO CENTRALITA C.D.I.
TE-SMR	3	8000A7905	1	SUPPORTO CENTRALINA INIEZIONE	BRACKET ENGINE CONTROL UNIT	SUPPORT UNITE' CONTROLE INJECTION	HALTER, EINSPRITZUNG ZENTRALANLAGE	SOPORTE CENTRAL INYECCION
SMR-TE	4	8000B0825	1	BOBINA ACCENSIONE	IGNITION COIL	BOBINE D'ALLUMAGE	ZUNDSPULE KOMPL.	BOBINA ENCENDIDO
TC-TXC	4	800091976	1	BOBINA ACCENSIONE	COIL, IGNITION	BOBINE ALLUMAGE	ZUENDSPULE	BOBINA ENCENDIDO
SMR-TE	5	800062728	2	VITE TEF M6X1X20 CH8	SCREW TEF M6X1X20 CH8	VIS TEF M6X1X20 CH8	SCHRAUBE TEF M6X1X20 CH8	TORNILLO TEF M6X1X20 CH8
TC-TXC	5	800062727	2	VITE TE M6X1X16 CH8	SCREW TE M6X1X16 CH8	VIS TE M6X1X16 CH8	SCHRAUBE TE M6X1X16 CH8	TORNILLO TE M6X1X16 CH8

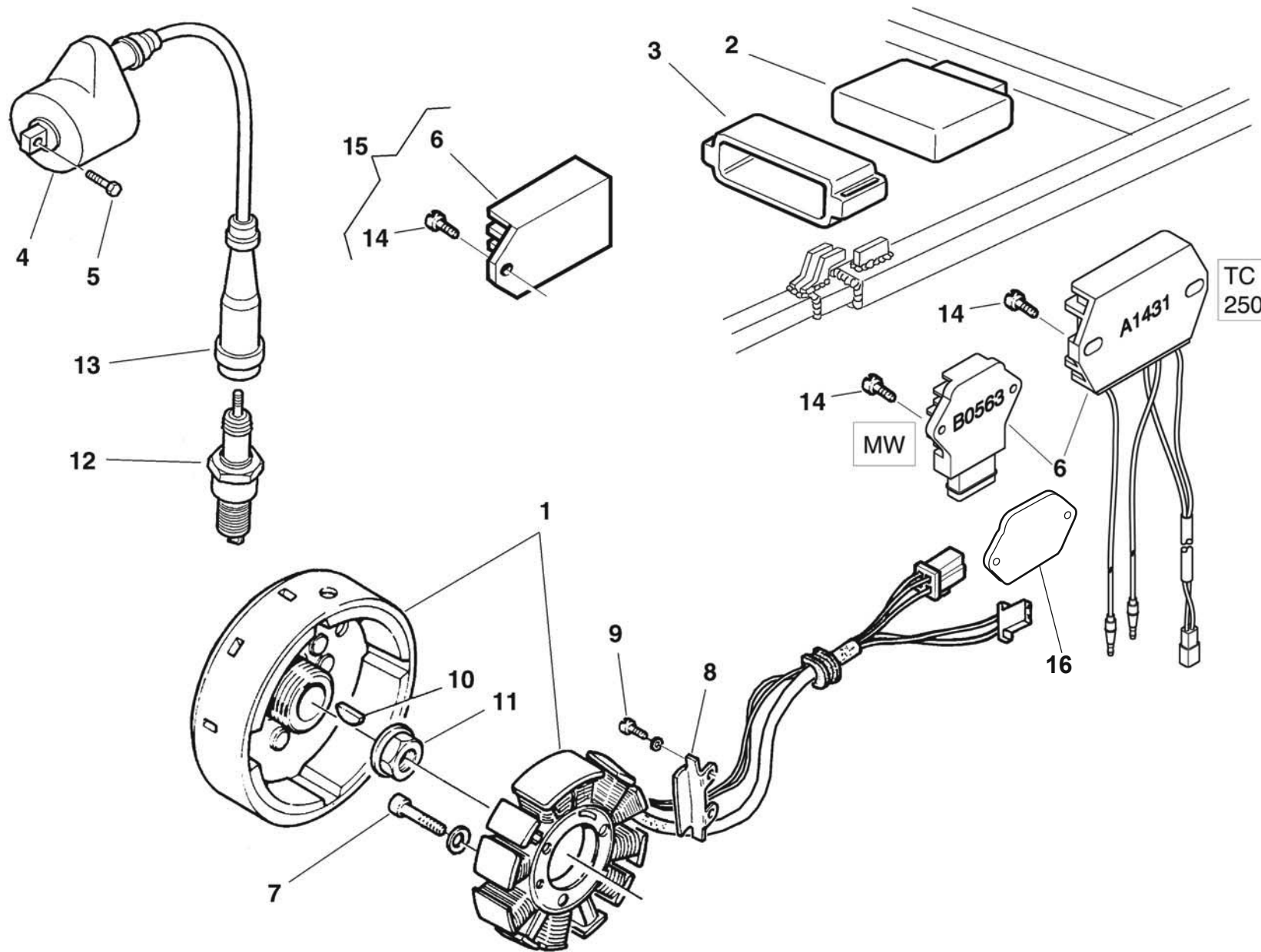

Note Notes Notes Marke Notas	Pos. No. N. Index Pos.	N. Cod. Code No. Nr. Code Code Nr N. Cod.	Q.tà Q.ty Q.te M.ge C.ad	DENOMINAZIONE	NAME	DESIGNATION	BESHREIBUNG	DENOMINACION
SMR-TE	6	8000B0563	1	REGOLATORE DI TENSIONE	REGULATOR & RECTIFIER	REGULATEUR TENSION	SPANNUNGSREGLER	REGULADOR TENSION
TC 250	6	8000A1431	1	REGOLATORE DI TENSIONE	REGULATOR & RECTIFIER	REGULATEUR TENSION	SPANNUNGSREGLER	REGULADOR TENSION
TC 450-510, TXC	6	800091978	1	REGOLATORE DI TENSIONE	REGULATOR & RECTIFIER	REGULATEUR TENSION	SPANNUNGSREGLER	REGULADOR TENSION
SMR-TE	7	8B0067997	3	VITE TEF M5X0,8X30 CH8	SCREW TEF M5X0.8X30 CH8	VIS TEF M5X0,8X30 CH8	SCHRAUBE TEF M5X0,8X30 CH8	TORNILLO TEF M5X0,8X30 CH8
TC 250	7	60N102488	2	VITE TCEI M5X0,8X25	SCREW TCEI M5X0.8X25	VIS TCEI M5X0,82X5	SCHRAUBE TCEI M5X0,8X25	TORNILLO TCEI M5X0,8X25
TC 450-510, TXC	7	800062728	2	VITE TEF M6X1X20 CH8	SCREW TEF M6X1X20 CH8	VIS TEF M6X1X20 CH8	SCHRAUBE TEF M6X1X20 CH8	TORNILLO TEF M6X1X20 CH8
	8	800099868	1	FERMACAVO	CLAMP, WIRE	COLLIER, CORDON	KABELKLEMME	GRAMPA CORDON
TC 250	9	60N102483	2	VITE TCEI M5X0,8X12	SCREW TCEI M5X0.8X12	VIS TCEI M5X0,8X12	SCHRAUBE TCEI M5X0,8X12	TORNILLO TCEI M5X0,8X12
TC 450-510, TXC-TE-SMR	9	8A0067997	2	VITE TEF M5X0,8X16	SCREW TEF M5X0.8X16	VIS TEF M5X0,8X16	SCHRAUBE TEF M5X0,8X16	TORNILLO TEF M5X0,8X16
	10	151371301	1	CHIAVETTA WOODRUFF	KEY, WOODRUFF	CLAVETTE, DEMI-LUNE WOODRUFF	EINLEGE KEIL, WOODRUFF	CHAVETA WOODRUFF
	11	8000A0033	1	DADO FLANGIATO M12X1	NUT FLANGE M12X1	ECROU BRIDE M12X1	GEFLANSCHTE MUTTER M12X1	TUERCA CON REBORDE M12X1
	12	8000A0573	1	CANDELA	PLUG, SPARK	BOUGIE	ZUENDKERZE	BUJIA
SMR-TE	13	8000A6740	1	PIPETTA CANDELA	CAP, SPARK PLUG	ANTIPARASITE	ZUENDKERZENSTECKER	CAPUCHON PORTA BUJIA
TC-TXC	13	8A00A0129	1	PIPETTA CANDELA	CAP, SPARK PLUG	ANTIPARASITE	ZUENDKERZENSTECKER	CAPUCHON PORTA BUJIA
SMR-TE	14	800062728	2	VITE TEF M6X1X20 CH8	SCREW TEF M6X1X20 CH8	VIS TEF M6X1X20 CH8	SCHRAUBE TEF M6X1X20 CH8	TORNILLO TEF M6X1X20 CH8
TC	14	800062728	1	VITE TEF M6X1X20 CH8	SCREW TEF M6X1X20 CH8	VIS TEF M6X1X20 CH8	SCHRAUBE TEF M6X1X20 CH8	TORNILLO TEF M6X1X20 CH8
TXC	14	800062727	1	VITE TE M6X1X16 CH8	SCREW TE M6X1X16 CH8	VIS TE M6X1X16 CH8	SCHRAUBE TE M6X1X16 CH8	TORNILLO TE M6X1X16 CH8
SMR-TE	16	8000B1061	1	PIASTRA	PLATE	PLAQUE	PLATTE	PLACA

**TC**

8

1÷5, 7, 9, 11, 12, 16, 27÷33

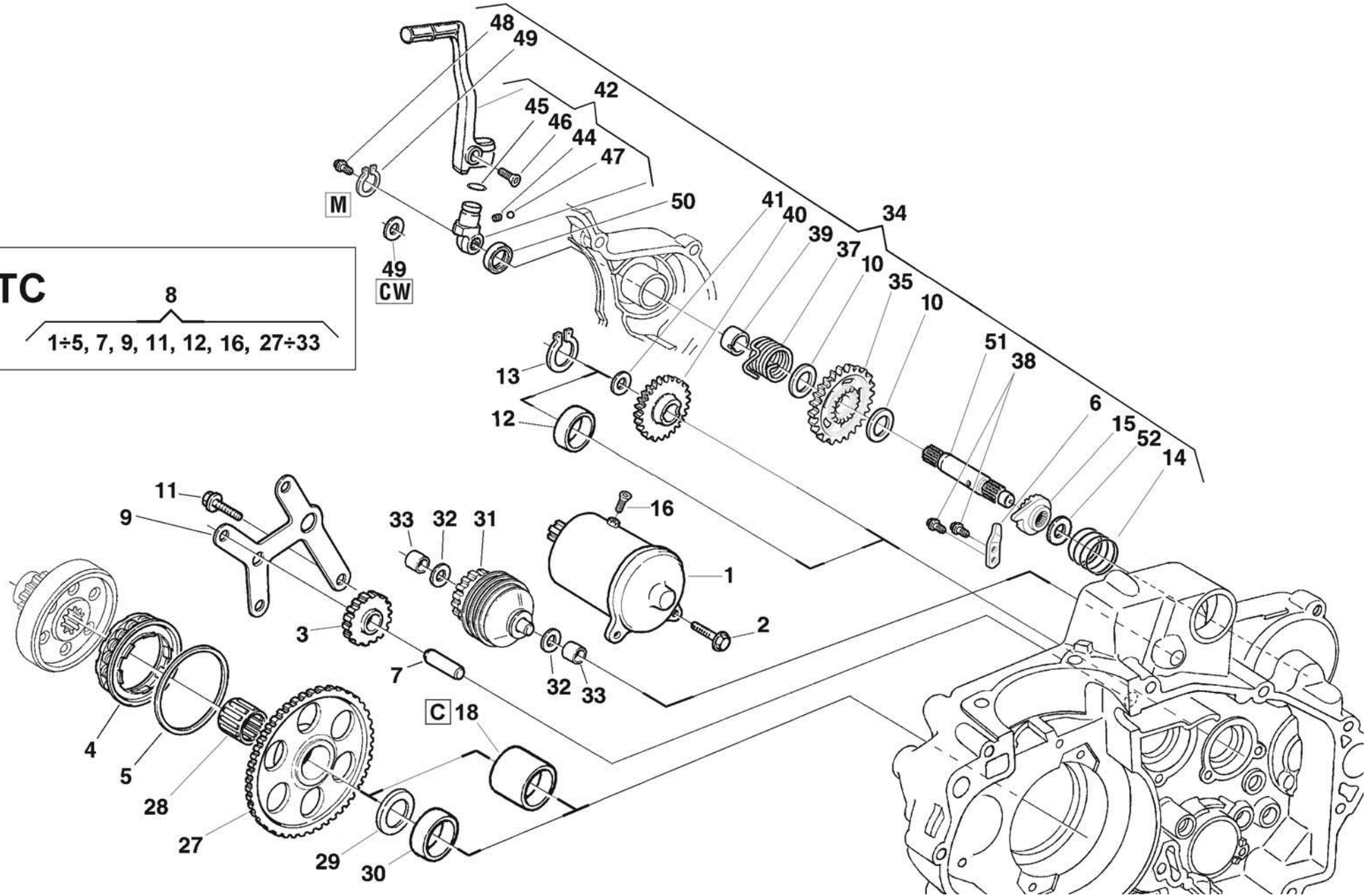

Note Notes Notas	Pos. No. N. Index Pos.	N. Cod. Code No. Nr. Code Code Nr N. Cod.	Q.tà Q.ty Q.te M.ge C.ad	DENOMINAZIONE	NAME	DESIGNATION	BESHREIBUNG	DENOMINACION
TE-SMR-TXC	1	8000B1373	1	MOTORINO AVVIAMENTO	STARTING MOTOR	DEMARREUR ELECTRIQUE	ANLASSERMOTOR	MOTOR ARRANQUE
TE-SMR-TXC	2	800062729	2	VITE TEF M6X1X25 CH8	SCREW TEF M6X1X25 CH8	VIS TEF M6X1X25 CH8	SCHRAUBE TEF M6X1X25 CH8	TORNILLO TEF M6X1X25 CH8
TE-SMR-TXC	3	800099958	1	INGRANAGGIO INTERMEDIO Z24	IDLE GEAR 24 T	PIGNON INTERMEDIAIRE D24	FREILAUFRAD Z24	ENGRANAJE INTERMEDIO D24
TE-SMR-TXC 450-510	4	8000A0709	1	RUOTA LIBERA	CLUTCH, ONE WAY	ROUE LIBRE	EINWEGKUPPLUNG	EMBRAGUE, UNA VIA
TE-TXC 250	4	800087289	1	RUOTA LIBERA	CLUTCH, ONE WAY	ROUE LIBRE	EINWEGKUPPLUNG	EMBRAGUE, UNA VIA
TE-SMR-TXC 450-510	5	8000A0710	1	DISCO RITEGNO RUOTA LIBERA	RETAINER, CLUTCH ONE WAY	ARRETOIR ROUE LIBRE	FREILAUF VERSCHLUSS	RETEN RUEDA LIBRE
TE250-TXC250	5	800086732	1	DISCO RITEGNO RUOTA LIBERA	RETAINER, CLUTCH ONE WAY	ARRETOIR ROUE LIBRE	FREILAUF VERSCHLUSS	RETEN RUEDA LIBRE
	6	8000A5890	1	PIASTRINA	PLATE	PLAQUETTE	PLAETTCHEN	PLETINA
TE-SMR-TXC	7	800099960	1	PERNO INGRANAGGIO INTERMEDIO	STARTER REDUCTION SHAFT	PIVOT ENGRANAGE	ZAHNRADSTIFT	PERNO ENGRANAJE INTERMEDIO
TC 250	8	8000B0428	1	KIT AVVIAMENTO ELETTRICO	STARTER SET ELECTRIC	KIT DEMARREUR ELECTRIQUE	ANLASSERMOTOR GRUPPE	KIT MOTOR DE ARRANQUE
TC 450-510	8	8000B0455	1	KIT AVVIAMENTO ELETTRICO	STARTER SET ELECTRIC	KIT DEMARREUR ELECTRIQUE	ANLASSERMOTOR GRUPPE	KIT MOTOR DE ARRANQUE
TE-SMR-TXC	9	8000A1022	1	PIASTRA	PLATE	PLAQUE	PLATTE	PLACA
TE-SMR-TXC	10	8G0010904	2	RONDELLA 26X17,2X1	WASHER 26X17,2X1	RONDELLE 26X17,2X1	SCHEIBE 26X17,2X1	ARANDELA 26X17,2X1
TE-SMR-TXC	11	800062727	4	VITE TE M6X1X16 CH8	SCREW TE M6X1X16 CH8	VIS TE M6X1X16 CH8	SCHRAUBE TE M6X1X16 CH8	TORNILLO TE M6X1X16 CH8
SMR	12	8000A0746	1	DISTANZIALE	SPACER	ENTRETOISE	ABSTANDHALTER	DISTANCIADOR
	13	66N021208	1	ANELLO ELASTICO 28X16,5 MM	SPRING RING 28X16,5 MM	BAGUE ELASTIQUE 28X16,5 MM	FEDERRING 28X16,5 MM	ANILLO ELASTICO 28X16,5 MM
TE-TC	14	8000A5895	1	MOLLA	SPRING	RESSORT	FEDER	MUELLE
TE-TC-TXC	15	8000B0034	1	CRICCHETTO SCORREVOLE	SLIDING GEAR	ENGRENAGE	ZAHNRAD	ENGRANAJE
TE-SMR-TXC	16	8F0067997	1	VITE TEF M5X0,8X6,5	SCREW TEF M5X0,8X6,5	VIS TEF M5X0,8X6,5	SCHRAUBE TEF M5X0,8X6,5	TORNILLO TEF M5X0,8X6,5
TC	18	8000A6470	1	DISTANZIALE	SPACER	ENTRETOISE	ABSTANDHALTER	DISTANCIADOR
TE-SMR-TXC 450-510	27	8000A0739	1	CORONA DENTATA Z70	RING GEAR T70	COURONNE DENTEE D70	ZAHNRAD Z70	CORONA DENTADA D70
TE-TXC 250	27	800099956	1	CORONA DENTATA Z70	RING GEAR T70	COURONNE DENTEE D70	ZAHNRAD Z70	CORONA DENTADA D70
TE-SMR-TXC	28	800035763	1	GABBIA A RULLI K28X33X17	NEEDLE BEARING K28X33X17	CAGE A ROULEMENT K28X33X17	ROLLENKAEFIG K28X33X17	JAULA DE RODILLOS K28X33X17
TE-SMR-TXC	29	8A0084473	1	RONDELLA RASAMENTO	WASHER, THRUST	RONDELLE BUTEE	DISTANZSCHEIBE	ARANDELA SEPARACION
TE-SMR-TXC 450-510	30	800099957	1	DISTANZIALE	SPACER	ENTRETOISE	ABSTANDHALTER	DISTANCIADOR
TE-TXC 250	30	8000A2933	1	DISTANZIALE	SPACER	ENTRETOISE	ABSTANDHALTER	DISTANCIADOR
TE-SMR-TXC	31	8000A1279	1	FRIZIONE AVVIAMENTO ELETTRICO	CLUTCH, ELECTRIC START	EMBAYAGE, DEMARRAGE ELECTRIQUE	KUPPLUNG, ELEKROANLASSER	EMBRAGUE ARRANQUE ELECTRICO
TE-SMR-TXC	32	800005876	2	RONDELLA 18X10X0,5	WASHER 18X10X0,5	RONDELLE 18X10X0,5	SCHEIBE 18X10X0,5	ARANDELA 18X10X0,5
TE-SMR-TXC	33	8000A1017	2	BOCCOLA	BUSH	DOUILLE	BUCHSE	BUJE
SMR	34	8000B0591	1	KIT AVVIAMENTO A PEDALE	KICK STARTER KIT	KIT DEMARRAGE A PEDALE	KIT KICKSTARTER ANLASSER	KIT ARRANQUA A PEDAL
TE-TC-TXC	35	8000B0031	1	INGRANAGGIO AVVIAMENTO Z 32	PINION KICK STARTER T32	PIGNON DE KICK DE DEMARRAGE D32	RITZEL, KICKSTARTER Z32	PINON, ARRANQUE DE PIE D32
TE-TC-TXC	37	8000A5894	1	MOLLA AVVIAMENTO	SPRING, KICK STARTER	RESSORT KICK DEMARRAGE	FEDER, KICKSTARTER	RESORTE, ARRANQUE PIE
	38	800028327	2	VITE TSEI M6X1,00X14 CH4	SCREW TSEI M6X1,00X14 CH4	VIS TSEI M6X1,00X14 CH4	SCHRAUBE TSEI M6X1,00X14 CH4	TORNILLO TSEI M6X1,00X14 CH4

**TC**

8

1÷5, 7, 9, 11, 12, 16, 27÷33

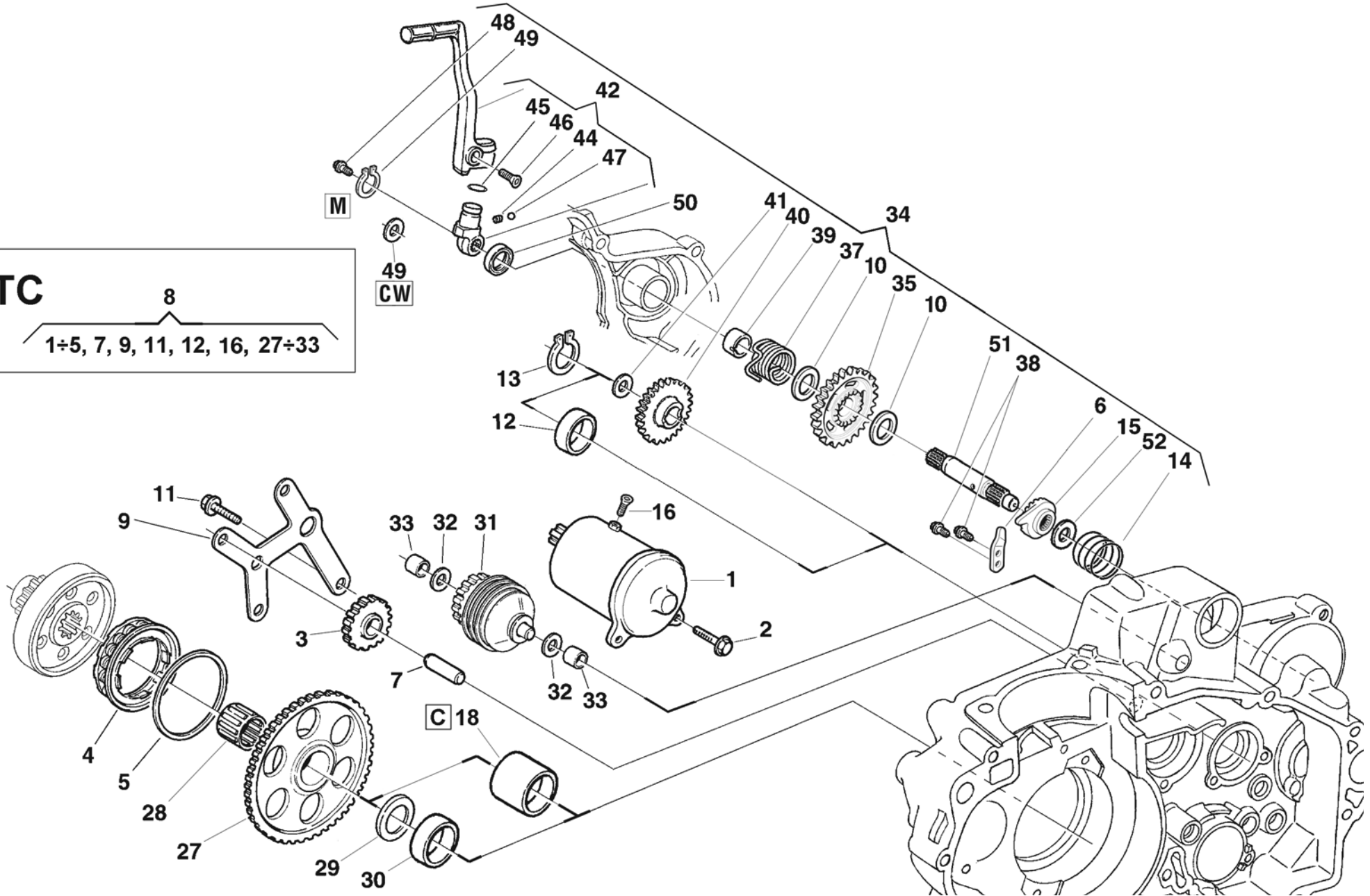





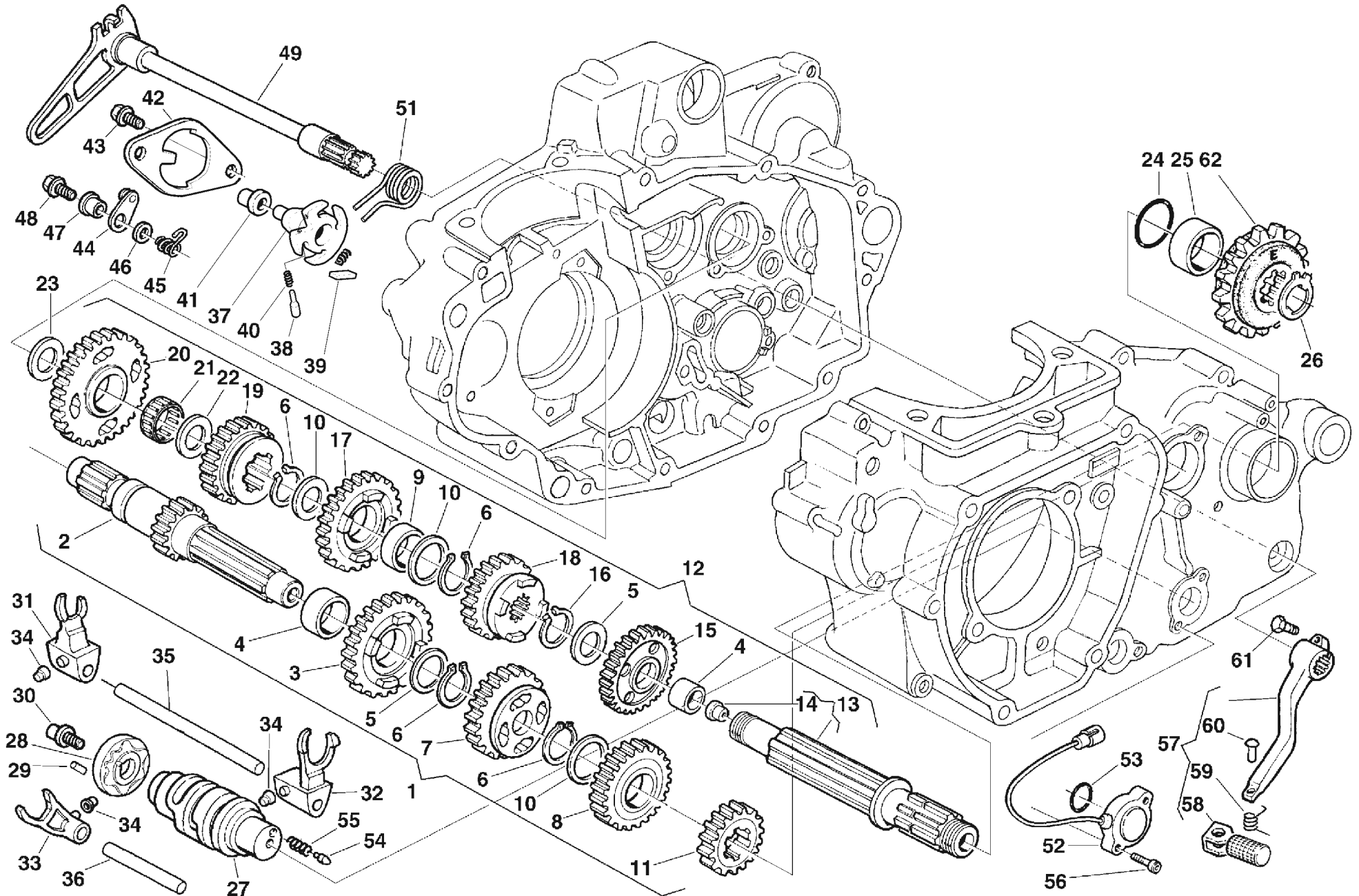

Note Notes Notas	Pos. No. N. Index Pos.	N. Cod. Code No. Nr. Code Code Nr N. Cod.	Q.tà Q.ty Q.te M.ge C.ad	DENOMINAZIONE	NAME	DESIGNATION	BESHREIBUNG	DENOMINACION
TC 250	1	8000A7759	1	ALBERO PRIMARIO COMPLETO	MAIN AXLE COMP.	ARBRE PRIMAIRE COMPLETE	HAUPTWELLE KOMPLETT	EJE PRIMARIO CAMBIO COMPLETO
TC 450-510	1	8000A5721	1	ALBERO PRIMARIO COMPLETO	COMPLETE MAIN SHAFT	ARBRE PRIMAIRE COMPLET	KOMPLETTE HAUPTWELLE	ARBOL PRIMARIO COMPLETO
TC 250	2	8000A1323	1	ALBERO PRIMARIO Z15	AXLE, MAIN 15T	ARBRE PRIMAIRE D15	HAUPTWELLE Z15	ARBOL PRINCIPAL CAMBIO D15
TC 450-510	2	8000A4244	1	ALBERO PRIMARIO Z15	AXLE, MAIN 15T	ARBRE PRIMAIRE D15	HAUPTWELLE Z15	ARBOL PRINCIPAL CAMBIO D15
	3	800099782	1	INGRANAGGIO CONDUTTORE 5A Z22	GEAR DRIVE 5TH SPEED T22	ENGRENAGE MENANT 5EME VITESSE D22	TREIBENDES ZAHNRAD 5. GESCHWIND. Z22	ENGRANAJE CONDUCTOR 5A VELOCIDAD D22
	4	800063822	2	BOCCOLA	BUSH 28X25X7	DOUILLE 28X25X7	BUCHSE 28X25X7	BUJE 28X25X7
	5	8D0036022	2	RONDELLA RASAMENTO 32X25,1X0,5 MM	THRUST WASHER 32X25,1X0,5 MM	RONDELLE DE BUTEE 32X25,1X0,5 MM	DISTANZSCHEIBE 32X25,1X0,5 MM	ARANDELA DE SEPARACION 32X25,1X0,5 MM
	6	800031772	4	ANELLO ELASTICO 23,2X1,2	CIRCLIP 23.2X1.2	BAGUE ELASTIQUE 23,2X1,2	SPRENGRING 23,2X1,2	ANILLO ELASTICO 23,2X1,2
	7	800099783	1	INGRANAGGIO CONDUTTORE 3A Z19	GEAR DRIVE 3RD SPEED T19	ENGRENAGE MENANT 3EME VITESSE D19	TREIBENDES ZAHNRAD 3. GESCHWIND. Z19	ENGRANAJE CONDUCTOR 3ERA VELOCIDAD D19
	8	800099784	1	INGRANAGGIO CONDUTTORE 4A Z23	GEAR, 4TH DRIVE NT:23	ENGRENAGE MENANT 4EME VITESSE D23	TREIBENDES ZAHNRAD 4. GESCHWINDIGK.Z23	ENGRANAJE CONDUCTOR 4A VELOCIDAD D23
	9	800063821	2	BOCCOLA	BUSH 28X25X9,9	DOUILLE 28X25X9,9	BUCHSE 28X25X9,9	BUJE 28X25X9,9
	10	800088255	3	RONDELLA RASAMENTO	WASHER, THRUST	RONDELLE BUTEE	DISTANZSCHEIBE	ARANDELA SEPARACION
TC 250	11	800099785	1	INGRANAGGIO CONDUTTORE 2A Z17	GEAR DRIVE 2ND SPEED T17	ENGRENAGE MENANT 2EME VITESSE D17	TREIBENDES ZAHNRAD 2. GESCHWIND. Z17	ENGRANAJE CONDUCTOR 2A VELOCIDAD D17
TC 450-510	11	8000A5723	1	INGRANAGGIO CONDUTTORE 2A Z18	GEAR, INPUT 2ND, 18T	ENGRENAGE MENANT 2EME VITESSE D18	TREIBENDES ZAHNRAD 2. GESCHWIND. Z18	ENGRANAJE CONDUCTOR 2NDA VELOCIDAD D18
TC 250	12	8000A1926	1	ALBERO SECONDARIO COMPLETO	COUNTER SHAFT ASSY	ARBRE SECONDAIRE COMPLET	NEBENGETRIEBEWELLE, KOMPLETT	EJE SECUNDARIO COMPLETO
TC 450-510	12	8000A5725	1	ALBERO SECONDARIO COMPLETO	COUNTER SHAFT ASSY	ARBRE SECONDAIRE COMPLET	NEBENGETRIEBEWELLE KOMPL.	ARBOL SECUNDARIO CAMBIO COMPLETO
	13	800099787	1	ALBERO SECONDARIO	COUNTER SHAFT	ARBRE SECONDAIRE	ANTRIEBSWELLE	ARBOL SECUNDARIO
	14	800057196	1	TAPPO 12X6X10	PLUG 12X6X10	BOUCHON 12X6X10	VERSCHLUSS 12X6X10	TAPON 12X6X10
TC 250	15	8000A1913	1	INGRANAGGIO CONDOTTO 2A Z26	DRIVEN GEAR 2ND SPEED T26	ENGRENAGE ENTRAINE 2ME VITESSE D26	ANGETRIEBENES ZAHNRAD 2. GESCHWIND.Z26	ENGRANAJE ACCIONADO 2A VELOCIDAD D26
TC 450-510	15	8000A5724	1	INGRANAGGIO CONDOTTO 2A Z26	DRIVEN GEAR 2ND SPEED T26	ENGRENAGE ENTRAINE 2EME VITESSE D26	ANGETRIEBENES ZAHNRAD 2. GESCHWIND.Z26	ENGRANAJE ACCIONADO 2NDA VELOCIDAD D26
	16	66N021211	3	ANELLO SEEGER 25MM DIN471	CIRCLIP 25MM DIN471	CIRCLIP 25MM DIN471	SPRENGRING 25MM DIN471	ANILLO SEEGER 25MM DIN471
	17	800099790	1	INGRANAGGIO CONDOTTO 3A Z24	DRIVEN GEAR 3TH SPEED T24	ENGRENAGE ENTRAINE 3EME VITESSE D24	ANGETRIEBENES ZAHNRAD 3. GESCHWIND. Z24	ENGRANAJE ACCIONADO 3ERA VELOCIDAD D24
	18	8000A1914	1	INGRANAGGIO CONDOTTO 4A Z25	DRIVEN GEAR 4TH SPEED T25	ENGRENAGE ENTRAINE 4EME VITESSE D25	ANGETRIEBENES ZAHNRAD 4. GESCHWIND.Z25	ENGRANAJE ACCIONADO 4A VELOCIDAD D25
	19	8000A1915	1	INGRANAGGIO CONDOTTO 5A Z21	DRIVEN GEAR 5TH SPEED T21	ENGRENAGE ENTRAINE 5EME VITESSE D21	ANGETRIEBENES ZAHNRAD 5. GESCHWIND. Z21	ENGRANAJE ACCIONADO 5A VELOCIDAD D21
	20	8000A1916	1	INGRANAGGIO CONDOTTO 1A Z28	DRIVEN GEAR 1ST SPEED T28	ENGRENAGE ENTRAINE 1ERE VITESSE D28	ANGETRIEBENES ZAHNRAD 1. GESCHWINDIG Z28	ENGRANAJE ACCIONADO 1ERA VELOCIDAD D28
	21	800022373	1	GABBIA A RULLI 20X24X10	BEARING, NEEDLE 20X24X10	ROULEMENT A AIGUILLES 20X24X10	NADELLAGER 20X24X10	COJINETE DE AGUJAS 20X24X10
	22	8G0007989	1	RONDELLA 28X20X1	WASHER 28X20X1	RONDELLE 28X20X1	SCHEIBE 28X20X1	ARANDELA 28X20X1
	23	8G0007989	1	RONDELLA 28X20X1	WASHER 28X20X1	RONDELLE 28X20X1	SCHEIBE 28X20X1	ARANDELA 28X20X1
	24	800041693	1	ANELLO O-RING 21,95X1,78	O-RING 21.95X1.78	JOINT TORIQUE 21,95X1,78	O-RING 21,95X1,78	JUNTA TORICA 21,95X1,78
	25	800086953	1	DISTANZIALE	SPACER	ENTRETOISE	ABSTANDHALTER	DISTANCIADOR
	26	66N021211	1	ANELLO SEEGER 25MM DIN471	CIRCLIP 25MM DIN471	CIRCLIP 25MM DIN471	SPRENGRING 25MM DIN471	ANILLO SEEGER 25MM DIN471
	27	800099919	1	TAMBURO DESMODROMICO	DRUM, CHANGE	TAMBOUR BOITE VITESSES	SCHALTTROMMEL	TAMBOR CAMBIO
	28	8A0097739	1	ROCCHETTO DESMODROMICO	CAM-CHANGE DRUM	PIGNION DESMODROMIQUE	VERSCHIEBENOCKENRITZEL	PINION TAMBOR CAMBIO

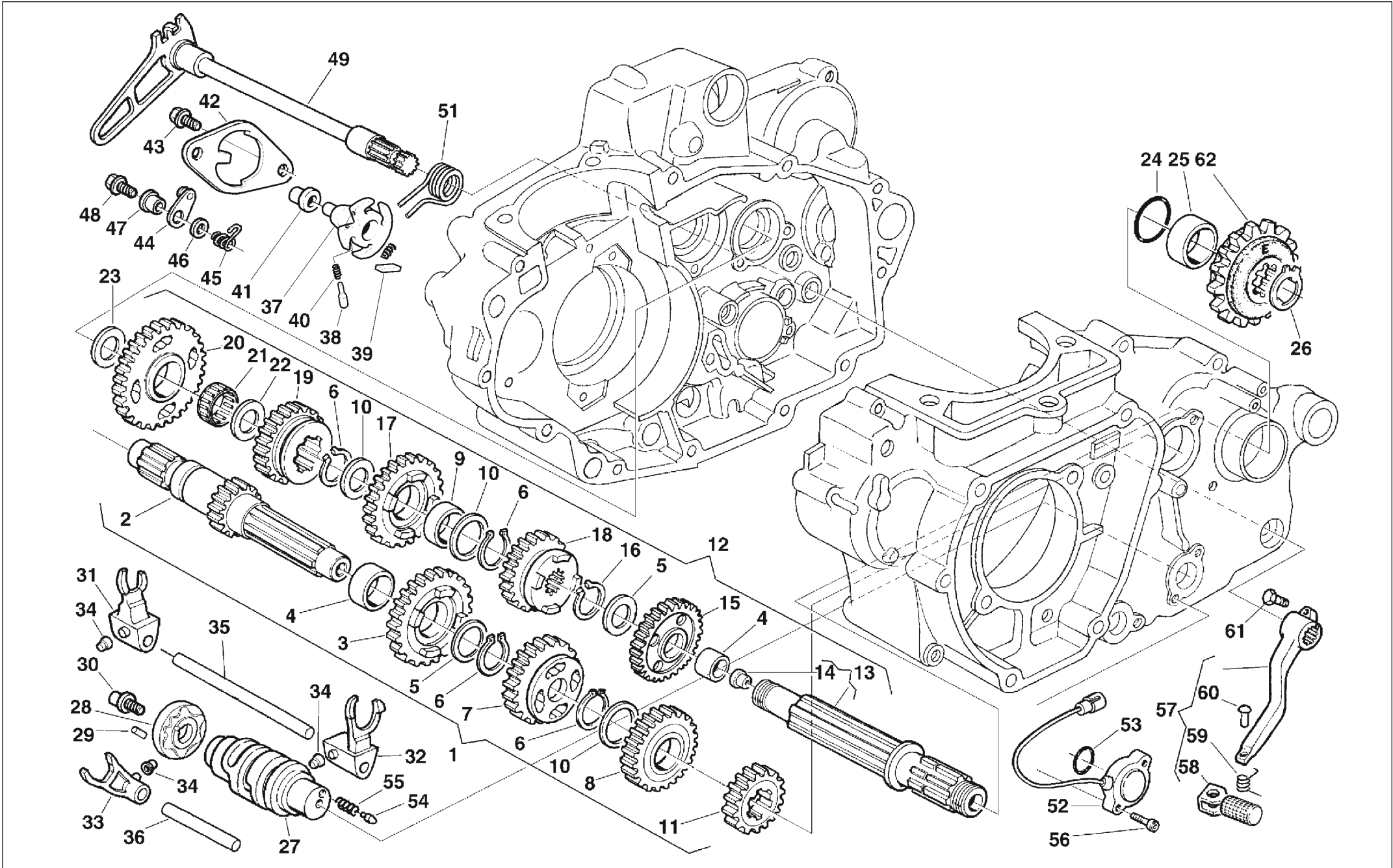

Note Notes Notas	Pos. No. Index Pos.	N. Cod. Code No. Nr. Code Code Nr N. Cod.	Q.tà Q.ty Q.te M.ge C.ad	DENOMINAZIONE	NAME	DESIGNATION	BESHREIBUNG	DENOMINACION
	29	800038520	1	RULLO 4X8	ROLLER 4X8	ROULEAU 4X8	ROLLE 4X8	RODILLO 4X8
	30	800098149	1	VITE	SCREW	VIS	SCHRAUBE	TORNILLO
	31	8000A0091	1	FORCELLA SELETTORE CAMBIO 1A	SHIFT FORK 1	FOURCHETTE SELECTEUR 1	SCHALTGABEL 1	HORQUILLA SELECTOR 1
	32	8000A0092	1	FORCELLA SELETTORE CAMBIO 2A-3A	SHIFT FORK 2-3	FOURCHETTE SELECTEUR 2-3	SCHALTGABEL 2-3	HORQUILLA SELECTOR 2-3
	33	800099738	1	FORCELLA SELETTORE CAMBIO 5A-6A	SHIFT FORK 5-6	FOURCHETTE SELECTEUR 5-6	SCHALTGABEL 5-6	HORQUILLA SELECTOR 5-6
	34	800071010	3	ROTELLA	ROLLER	ROULEAU	ROLLENKERN	RODILLO
	35	800038711	1	ASSE FORCHETTA CAMBIO 96 MM	AXLE, SHIFT FORK GUIDE 96 MM	AXE FOURCHETTE CHANGEMENT VITESSE 96 MM	ACHSE, GANGSCHALTGABEL 96 MM	EJE GUIA HORQUILLA CAMBIO 96 MM
	36	800038712	1	ASSE FORCHETTA CAMBIO 57,5 MM	AXLE, SHIFT FORK GUIDE 57.5 MM	AXE FOURCHETTE CHANGEMENT VITESSE 57,5	ACHSE, GANGSCHALTGABEL 57,5 MM	EJE GUIA HORQUILLA CAMBIO 57,5 MM
	37	800087299	1	ROCCHETTO SELETTORE	SELECTOR SPROCKET	CROCHET SELECTEUR	KLEINRAD GANGWAHL	CORONA SELECTOR
	38	800071007	2	SALTARELLO ROCCHETTO	PAWL	CLIQUET	STRUMHAKEN	SALTARELO
	39	800071008	2	PUNTALE SALTARELLO	PUSH ROD	BARRE PRESSION	DRUCKSTANGE	VARILLA PRESION
	40	800071009	2	MOLLA PUNTALE	SPRING	RESSORT	FEDER	MUELLE
	41	800071010	1	ROTELLA	ROLLER	ROULEAU	ROLLENKERN	RODILLO
	42	8000A7514	1	PIASTRINA	PLATE	PLAQUETTE	PLAETTCHEN	PLETINA
	43	800062726	2	VITE TEF M6X1,00X14 CH8	SCREW TEF M6X1.00X14 CH8	VIS TEF M6X1,00X14 CH8	SCHRAUBE TEF M6X1,00X14 CH8	TORNILLO TEF M6X1,00X14 CH8
	44	800085495	1	SALTARELLO FISSA MARCE	GEAR FIXING CLICK ASSEMBLY	CLIQUET COMPLETE	SPERRKLINKE. KPL.	TRINQUETE FIJO MARCHAS
	45	8000A1748	1	MOLLA	SPRING	RESSORT	FEDER	MUELLE
	46	800086107	1	RONDELLA RASAMENTO 6,2X20	THRUST WASHER 6.2X20	RONDELLE DE BUTEE 6,2X20	DISTANZSCHEIBE 6,2X20	ARANDELA DE SEPARACION 6,2X20
	47	800085493	1	BUSSOLA ROTAZIONE SALTARELLO	BUSH	DOUILLE	BUCHSE	BUJE
	48	800062726	1	VITE TEF M6X1,00X14 CH8	SCREW TEF M6X1.00X14 CH8	VIS TEF M6X1,00X14 CH8	SCHRAUBE TEF M6X1,00X14 CH8	TORNILLO TEF M6X1,00X14 CH8
	49	800091559	1	ALBERO SELETTORE CAMBIO	GEAR SELECTOR SHAFT	ARBRE SELECTEUR	SCHALTWELLE	ARBOL SELECTOR
	51	800072826	1	MOLLA CAMBIO	SPRING, SHIFT RETURN	RESSORT RAPPEL LEVIER COMMANDE	RUECKHOLFEDER SCHALTHEBEL	MUELLE RETRACTOR PALANCA CAMBIO
	52	8000A4511	1	INTERRUTTORE FOLLE	SWITCH, NEUTRAL	INTERRUPTEUR TEMOIN POINT MORT	SCHALTER LEERLAUFLEUCHTE	INTERRUPTOR PUNTO MUERTO
	53	8A0042700	1	ANELLO O-RING 2093 23,52X1,78 MM	O-RING 2093 23.52X1.78 MM	JOINT TORIQUE 2093 23,52X1,78 MM	O-RING 2093 23,52X1,78 MM	JUNTA TORICA 2093 23,52X1,78 MM
	54	800042676	1	PUNTALE FOLLE	POINT, NEUTRAL	CONTACTEUR POINT-MORT	BOLZEN LEERLAUF	PUNTO NEUTRO
	55	800042677	1	MOLLA PUNTALE	SPRING	RESSORT	FEDER	MUELLE
	56	800066525	2	VITE TEF M5X0,8X12	SCREW TEF M5X0.8X12	VIS TEF M5X0,8X12	SCHRAUBE TEF M5X0,8X12	TORNILLO TEF M5X0,8X12
	57	8000A3488	1	PEDALE CAMBIO	PEDAL, GEAR CHANGE	PEDALE CHANGEMENT VITESSE	SCHALTPEDAL	PEDAL, CAMBIO VELOCIDADES
	58	8A00A3485	1	BRACCIO PEDALE CAMBIO	ARM, GEAR SHIFT LEVER	BRAS PEDAL CHANGEMENT VITESSE	ARM, SCHALTPEDAL	BRAZO, PEDAL CAMBIO
	59	800070216	1	MOLLA	SPRING	RESSORT	FEDER	MUELLE

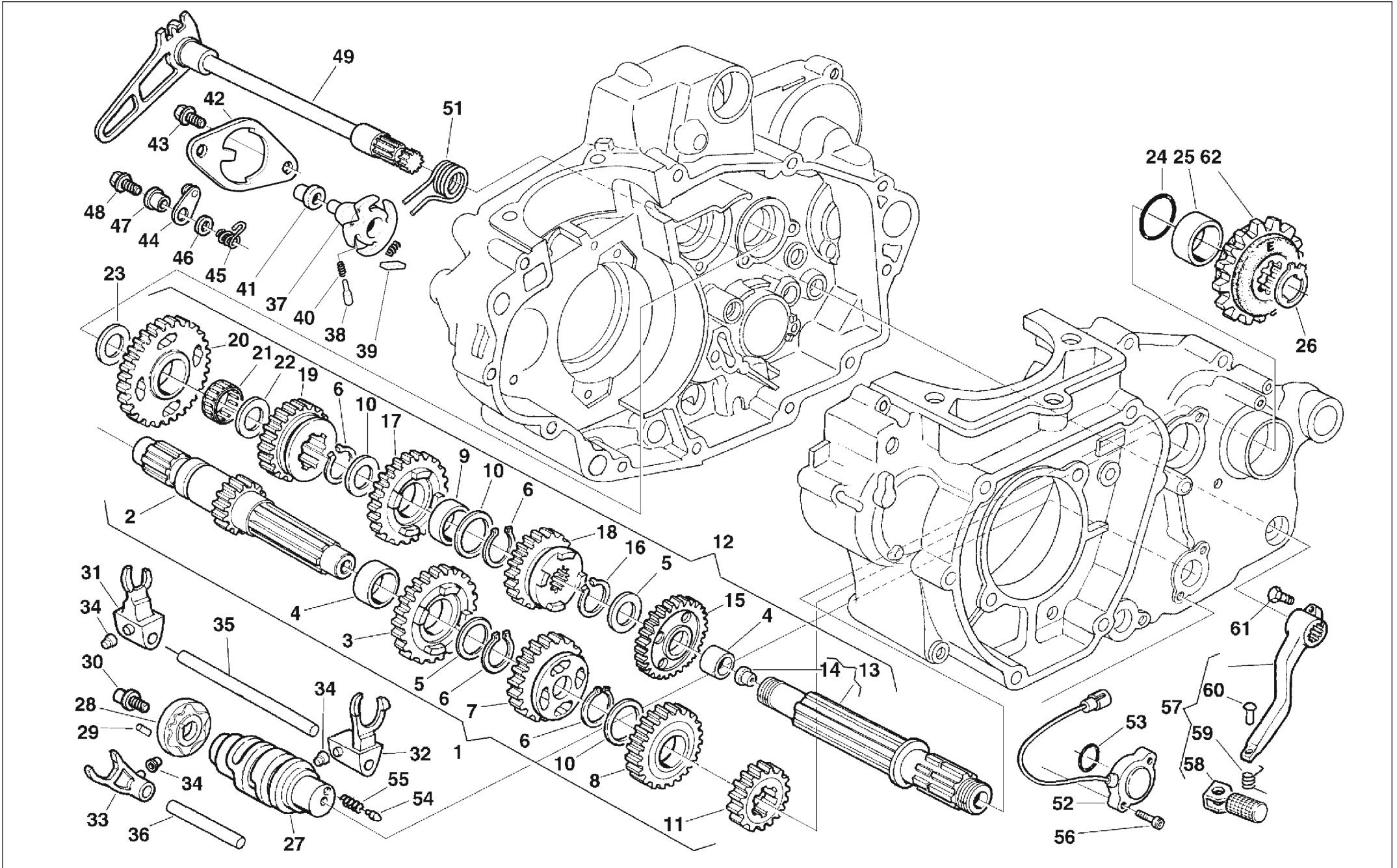



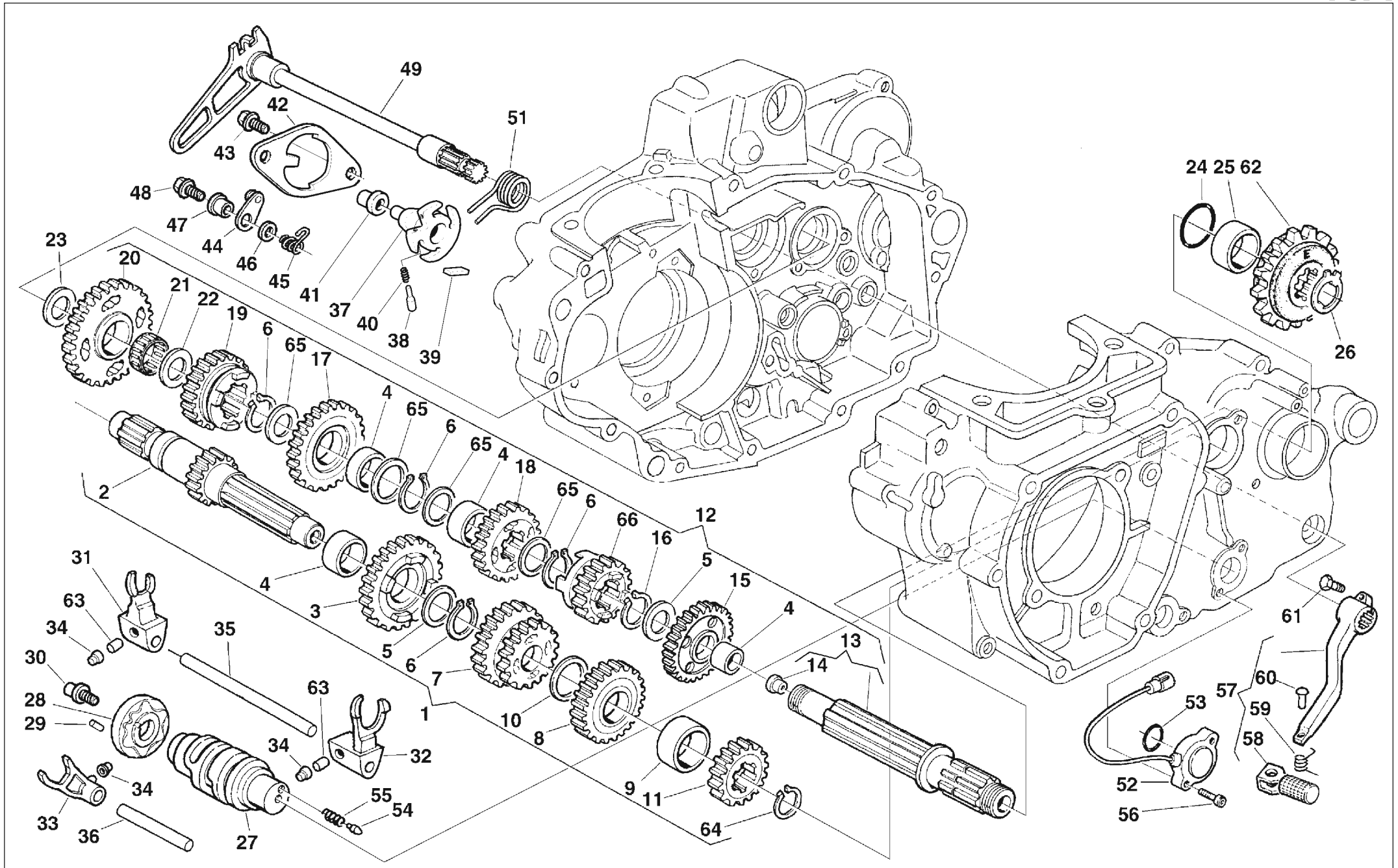



Note Notes Notes Marke Notas	Pos. No. N. Index Pos.	N. Cod. Code No. Nr. Code Code Nr N. Cod.	Q.tà Q.ty Q.te M.ge C.ad	DENOMINAZIONE	NAME	DESIGNATION	BESHREIBUNG	DENOMINACION
250	1	8000A4592	1	ALBERO PRIMARIO COMPLETO	COMPLETE MAIN SHAFT	ARBRE PRIMAIRE COMPLET	KOMPLETTE HAUPTWELLE	ARBOL PRIMARIO COMPLETO
450-510	1	8000A3511	1	ALBERO PRIMARIO COMPLETO	COMPLETE MAIN SHAFT	ARBRE PRIMAIRE COMPLET	KOMPLETTE HAUPTWELLE	ARBOL PRIMARIO COMPLETO
250	2	8000A1300	1	ALBERO PRIMARIO Z14	AXLE MAIN 14T	ARBRE PRIMAIRE D14	HAUPTWELLE Z14	ARBOL PRIMARIO CAMBIO D14
450-510	2	8000A3512	1	ALBERO PRIMARIO Z14	AXLE MAIN 14T	ARBRE PRIMAIRE D14	HAUPTWELLE Z14	ARBOL PRIMARIO CAMBIO D14
	3	800088244	1	INGRANAGGIO CONDUTTORE 5A Z25	GEAR, 5TH PINION 25T	ENGRENAGE MENANT 5EME VITESSE D25	TREIBENDES ZAHNRAD 5. GESCHWIND. Z25	ENGRANAJE CONDUCTOR 5A VELOCIDAD D25
	4	800063822	5	BOCCOLA	BUSH 28X25X7	DOUILLE 28X25X7	BUCHSE 28X25X7	BUJE 28X25X7
	5	8D0036022	2	RONDELLA RASAMENTO 32X25,1X0,5 MM	THRUST WASHER 32X25.1X0.5 MM	RONDELLE DE BUTEE 32X25.1X0.5 MM	DISTANZSCHEIBE 32X25,1X0,5 MM	ARANDELA DE SEPARACION 32X25,1X0,5 MM
	6	800031772	4	ANELLO ELASTICO 23,2X1,2	CIRCLIP 23.2X1.2	BAGUE ELASTIQUE 23,2X1,2	SPRENGRING 23,2X1,2	ANILLO ELASTICO 23,2X1,2
	7	8000A3972	1	INGRANAGGIO CONDUTTORE 3A-4A Z18/23	GEAR DRIVE 3/4TH SPEED T18/23	ENGRENAGE MENANT 3/4EME VITESSE D18/23	TREIBENDES ZAHNRAD 3/4. GESCHWIND.Z18/23	ENGRANAJE CONDUCTOR 3/4A VEL. D18/23
	8	800088246	1	INGRANAGGIO CONDOTTO 6A Z27	DRIVEN GEAR 6TH SPEED 27T	ENGRENAGE ENTRAINE 6EME VITESSE D27	ANGETRIEBENES ZAHNRAD 6. GESCHWIND.Z27	ENGRANAJE ACCIONADO 6A VELOCIDAD D27
	9	8A0061261	1	BUSSOLA 25X22	BUSH 25X22	DOUILLE 25X22	BUCHSE 25X22	CASQUILLO 25X22
	10	8B0036023	1	RONDELLA RASAMENTO	WASHER, THRUST	RONDELLE BUTEE	DISTANZSCHEIBE	ARANDELA SEPARACION
	11	800088247	1	INGRANAGGIO CONDUTTORE 2A Z18	GEAR, INPUT 2ND, 18T	ENGRENAGE MENANT 2EME VITESSE D18	TREIBENDES ZAHNRAD 2. GESCHWIND. Z18	ENGRANAJE CONDUCTOR 2NDA VELOCIDAD D18
	12	8000A3971	1	ALBERO SECONDARIO COMPLETO	COUNTER SHAFT ASSY	ARBRE SECONDAIRE COMPLET	NEBENGETRIEBEWELLE KOMPL.	ARBOL SECUNDARIO CAMBIO COMPLETO
	13	8000A1302	1	ALBERO SECONDARIO	COUNTER SHAFT	ARBRE SECONDAIRE	ANTRIEBSWELLE	ARBOL SECUNDARIO
	14	800057196	1	TAPPO 12X6X10	PLUG 12X6X10	BOUCHON 12X6X10	VERSCHLUSS 12X6X10	TAPON 12X6X10
	15	8000A1918	1	INGRANAGGIO CONDOTTO 2A Z29	DRIVEN GEAR 2ND SPEED T29	ENGRENAGE ENTRAINE 2EME VITESSE D29	ANGETRIEBENES ZAHNRAD 2. GESCHWIND.Z29	ENGRANAJE ACCIONADO 2NDA VELOCIDAD D29
	16	66N021211	3	ANELLO SEEGER 25MM DIN471	CIRCLIP 25MM DIN471	CIRCLIP 25MM DIN471	SPRENGRING 25MM DIN471	ANILLO SEEGER 25MM DIN471
	17	800088254	1	INGRANAGGIO CONDOTTO 4A Z25	DRIVEN GEAR 4TH SPEED T:25	ENGRENAGE ENTRAINE 4EME VITESSE D25	ANGETRIEBENES ZAHNRAD 4. GESCHWIND.Z25	ENGRANAJE ACCIONADO 4A VELOCIDAD D25
	18	8000A3970	1	INGRANAGGIO CONDOTTO 3A Z24	DRIVEN GEAR 3TH SPEED T24	ENGRENAGE ENTRAINE 3EME VITESSE D24	ANGETRIEBENES ZAHNRAD 3. GESCHWIND. Z24	ENGRANAJE ACCIONADO 3ERA VELOCIDAD D24
	19	8000A1920	1	INGRANAGGIO CONDOTTO 5A Z23	DRIVEN GEAR 5TH SPEED 23T	ENGRENAGE ENTRAINE 5EME VITESSE D23	ANGETRIEBENES ZAHNRAD 5. GESCHWIND.Z23	ENGRANAJE ACCIONADO 5A VELOCIDAD D23
	20	8000A1921	1	INGRANAGGIO CONDOTTO 1A Z28	DRIVEN GEAR 1ST SPEED T28	ENGRENAGE ENTRAINE 1ERE VITESSE D28	ANGETRIEBENES ZAHNRAD 1. GESCHWINDIG Z28	ENGRANAJE ACCIONADO 1ERA VELOCIDAD D28
	21	800022373	1	GABBIA A RULLI 20X24X10	BEARING, NEEDLE 20X24X10	ROULEMENT A AIGUILLES 20X24X10	NADELLAGER 20X24X10	COJINETE DE AGUJAS 20X24X10
	22	8G0007989	1	RONDELLA 28X20X1	WASHER 28X20X1	RONDELLE 28X20X1	SCHEIBE 28X20X1	ARANDELA 28X20X1
	23	8G0007989	1	RONDELLA 28X20X1	WASHER 28X20X1	RONDELLE 28X20X1	SCHEIBE 28X20X1	ARANDELA 28X20X1
	24	800041693	1	ANELLO O-RING 21,95X1,78	O-RING 21.95X1.78	JOINT TORIQUE 21,95X1,78	O-RING 21,95X1,78	JUNTA TORICA 21,95X1,78
	25	800086953	1	DISTANZIALE	SPACER	ENTRETOISE	ABSTANDHALTER	DISTANCIADOR
	26	66N021211	1	ANELLO SEEGER 25MM DIN471	CIRCLIP 25MM DIN471	CIRCLIP 25MM DIN471	SPRENGRING 25MM DIN471	ANILLO SEEGER 25MM DIN471
	27	8000A1316	1	TAMBURO DESMODROMICO	DRUM, CHANGE	TAMBOUR BOITE VITESSES	SCHALTROMMEL	TAMBOR CAMBIO
	28	8A0097739	1	ROCCHETTO DESMODROMICO	CAM-CHANGE DRUM	PIGNION DESMODROMIQUE	VERSCHIEBENOCKENRITZEL	PINION TAMBOR CAMBIO
	29	800038520	1	RULLO 4X8	ROLLER 4X8	ROULEAU 4X8	ROLLE 4X8	RODILLO 4X8
	30	800098149	1	VITE	SCREW	VIS	SCHRAUBE	TORNILLO
	31	8A0086980	1	FORCELLA SELETTORE CAMBIO 1A-4A	SHIFT FORK 1-4	FOURCHETTE SELECTEUR 1-4	SCHALTGABEL 1-4	HORQUILLA SELECTOR 1-4

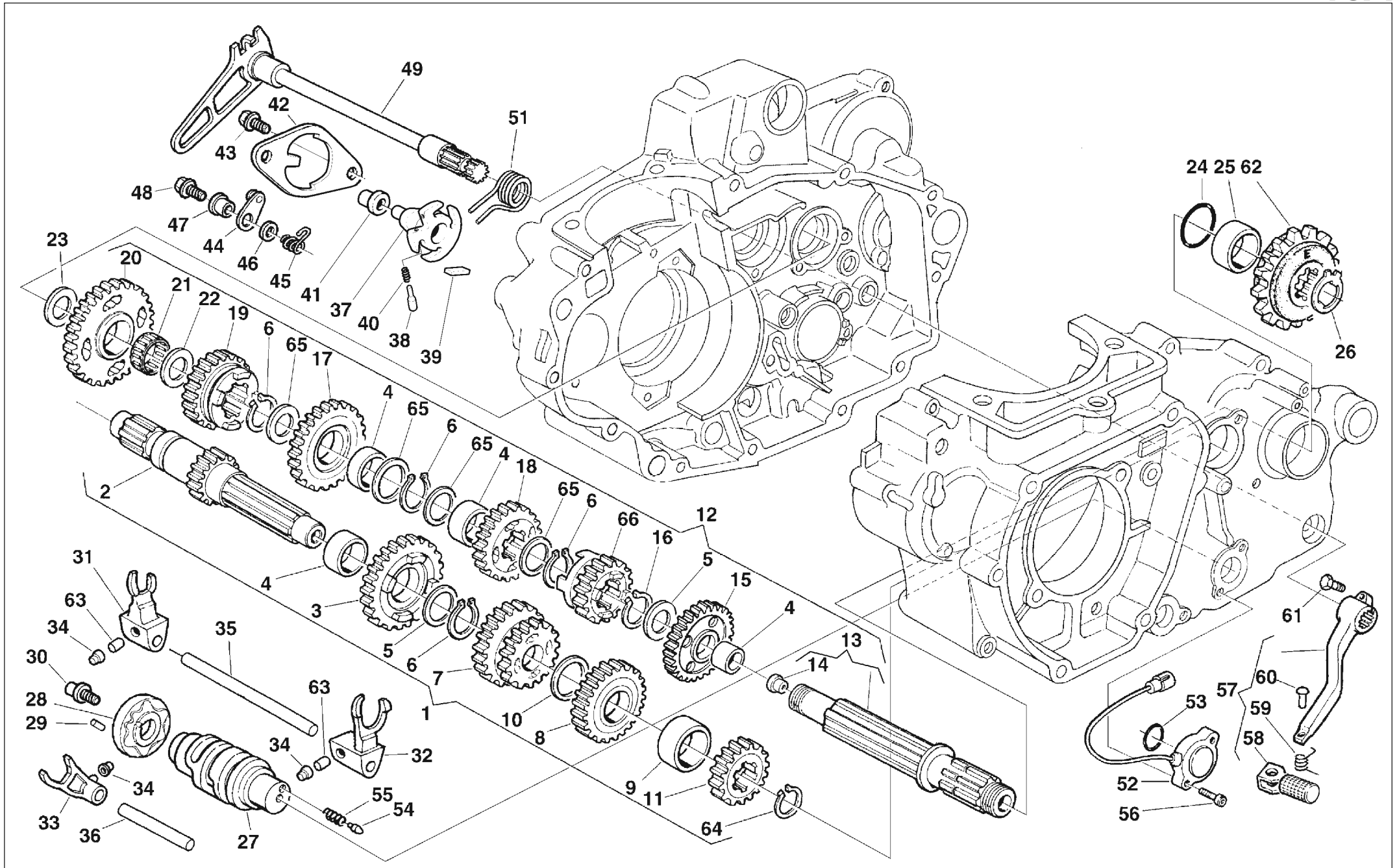

Note Notes Marke Notas	Pos. No. N. Index Pos.	N. Cod. Code No. Nr. Code Code Nr N. Cod.	Q.tà Q.ty Q.te M.ge C.ad	DENOMINAZIONE	NAME	DESIGNATION	BESHREIBUNG	DENOMINACION
	32	8A0048127	1	FORCELLA SELETTORE CAMBIO 2A-3A	SHIFT FORK 2-3	FOURCHETTE SELECTEUR 2-3	SCHALTGABEL 2-3	HORQUILLA SELECTOR 2-3
	33	800099738	1	FORCELLA SELETTORE CAMBIO 5A-6A	SHIFT FORK 5-6	FOURCHETTE SELECTEUR 5-6	SCHALTGABEL 5-6	HORQUILLA SELECTOR 5-6
	34	800071010	3	ROTELLA	ROLLER	ROULEAU	ROLLENKERN	RODILLO
	35	800038711	1	ASSE FORCHETTA CAMBIO 96 MM	AXLE, SHIFT FORK GUIDE 96 MM	AXE FOURCHETTE CHANGEMENT VITESSE 96 MM	ACHSE, GANGSCHALTGABEL 96 MM	EJE GUIA HORQUILLA CAMBIO 96 MM
	36	800038712	1	ASSE FORCHETTA CAMBIO 57,5 MM	AXLE, SHIFT FORK GUIDE 57,5 MM	AXE FOURCHETTE CHANGEMENT VITESSE 57,5	ACHSE, GANGSCHALTGABEL 57,5 MM	EJE GUIA HORQUILLA CAMBIO 57,5 MM
	37	800087299	1	ROCCHETTO SELETTORE	SELECTOR SPROCKET	CROCHET SELECTEUR	KLEINRAD GANGWAHL	CORONA SELECTOR
	38	800071007	2	SALTARELLO ROCCHETTO	PAWL	CLIQUET	STRUMHAKEN	SALTARELO
	39	800071008	2	PUNTALE SALTARELLO	PUSH ROD	BARRE PRESSION	DRUCKSTANGE	VARILLA PRESION
	40	800071009	2	MOLLA PUNTALE	SPRING	RESSORT	FEDER	MUELLE
	41	800071010	1	ROTELLA	ROLLER	ROULEAU	ROLLENKERN	RODILLO
	42	8000A7514	1	PIASTRINA	PLATE	PLAQUETTE	PLAETTCHEN	PLETINA
	43	800062726	2	VITE TEF M6X1,00X14 CH8	SCREW TEF M6X1.00X14 CH8	VIS TEF M6X1,00X14 CH8	SCHRAUBE TEF M6X1,00X14 CH8	TORNILLO TEF M6X1,00X14 CH8
	44	800085495	1	SALTARELLO FISSA MARCE	GEAR FIXING CLICK ASSEMBLY	CLIQUET COMPLETE	SPERRKLINKE. KPL.	TRINQUETE FIJO MARCHAS
	45	8000A1748	1	MOLLA	SPRING	RESSORT	FEDER	MUELLE
	46	800086107	1	RONDELLA RASAMENTO 6,2X20	THRUST WASHER 6.2X20	RONDELLE DE BUTEE 6,2X20	DISTANZSCHEIBE 6,2X20	ARANDELA DE SEPARACION 6,2X20
	47	800085493	1	BUSSOLA ROTAZIONE SALTARELLO	BUSH	DOUILLE	BUCHSE	BUJE
	48	800062726	1	VITE TEF M6X1,00X14 CH8	SCREW TEF M6X1.00X14 CH8	VIS TEF M6X1,00X14 CH8	SCHRAUBE TEF M6X1,00X14 CH8	TORNILLO TEF M6X1,00X14 CH8
	49	800091559	1	ALBERO SELETTORE CAMBIO	GEAR SELECTOR SHAFT	ARBRE SELECTEUR	SCHALTWELLE	ARBOL SELECTOR
	51	800072826	1	MOLLA CAMBIO	SPRING, SHIFT RETURN	RESSORT RAPPEL LEVIER COMMANDE	RUECKHOLFEDER SCHALTHEBEL	MUELLE RETRACTOR PALANCA CAMBIO
TE-SMR	52	8000A6751	1	SEGNALATORE MARCE	SENSOR ASSY, GEAR POSITION	CAPTEUR POINT MORT	SENSOR LEERLAUF	SENSOR PUNTO MUERTO
TXC	52	8000A4511	1	INTERRUTTORE FOLLE	SWITCH, NEUTRAL	INTERRUPTEUR TEMOIN POINT MORT	SCHALTER LEERLAUFLEUCHTE	INTERRUPTOR PUNTO MUERTO
	53	8A0042700	1	ANELLO O-RING 2093 23,52X1,78 MM	O-RING 2093 23.52X1.78 MM	JOINT TORIQUE 2093 23,52X1,78 MM	O-RING 2093 23,52X1,78 MM	JUNTA TORICA 2093 23,52X1,78 MM
	54	800042676	1	PUNTALE FOLLE	POINT, NEUTRAL	CONTACTEUR POINT-MORT	BOLZEN LEERLAUF	PUNTO NEUTRO
	55	800042677	1	MOLLA PUNTALE	SPRING	RESSORT	FEDER	MUELLE
	56	800066525	2	VITE TEF M5X0,8X12	SCREW TEF M5X0.8X12	VIS TEF M5X0,8X12	SCHRAUBE TEF M5X0,8X12	TORNILLO TEF M5X0,8X12
	57	8000A3488	1	PEDALE CAMBIO	PEDAL, GEAR CHANGE	PEDALE CHANGEMENT VITESSE	SCHALTPEDAL	PEDAL, CAMBIO VELOCIDADES
	58	8A00A3485	1	BRACCIO PEDALE CAMBIO	ARM, GEAR SHIFT LEVER	BRAS PEDAL CHANGEMENT VITESSE	ARM, SCHALTPEDAL	BRAZO, PEDAL CAMBIO
	59	800070216	1	MOLLA	SPRING	RESSORT	FEDER	MUELLE
	60	800099744	1	RIBATTINO 6X22 UNI 748	RIVET 6X22 UNI 748	RIVET 6X22 UNI 748	NIETE 6X22 UNI 748	REMACHE 6X22 UNI 748
	61	800062728	1	VITE TEF M6X1X20 CH8	SCREW TEF M6X1X20 CH8	VIS TEF M6X1X20 CH8	SCHRAUBE TEF M6X1X20 CH8	TORNILLO TEF M6X1X20 CH8
	62	800063830	1	PIGNONE Z15	SPROCKET, CHAIN T15	PIGNON CHAINE Z15	KETTENRITZEL Z15	PINON CADENA Z15
	62	800063827	1	PIGNONE Z12	SPROCKET, CHAIN T12	PIGNON CHAINE D12	KETTENRITZEL Z12	PINON CADENA D12
STD SMR	62	800063829	1	PIGNONE Z14	SPROCKET, CHAIN T14	PIGNON CHAINE Z14	KETTENRITZEL Z14	PINON CADENA Z14

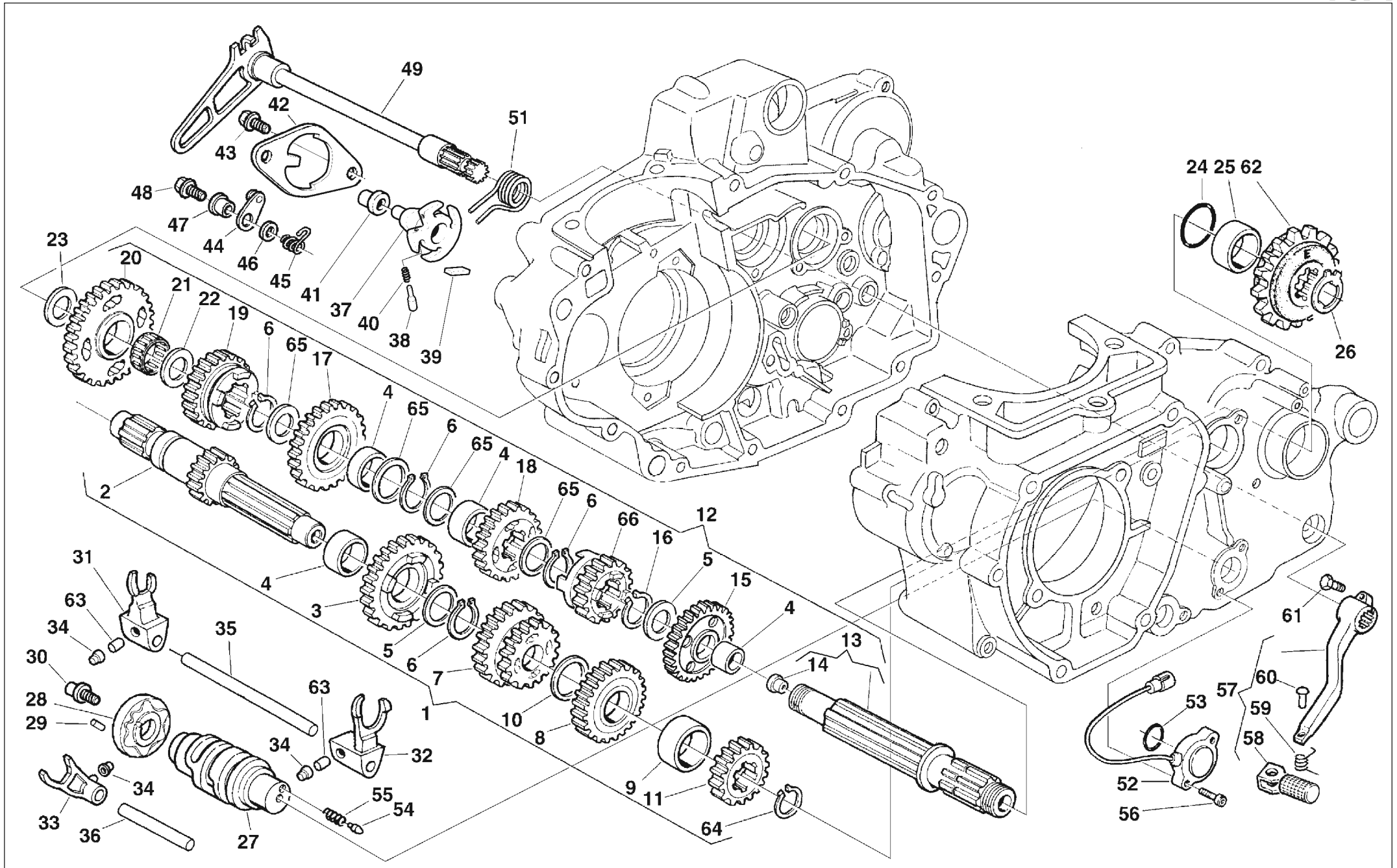





Note Notes Notas	Pos. No. Index Pos.	N. Cod. Code No. Nr. Code Code Nr N. Cod.	Q.tà Q.ty Q.te M.ge C.ad	DENOMINAZIONE	NAME	DESIGNATION	BESHREIBUNG	DENOMINACION
250	1	8A0060415	1	GIRANTE POMPA ACQUA	IMPELLER, WATER PUMP	TURBINE POMPE A EAU	WASSERPUMPE LAUFSCHWUNGRAD	ROTOR BOMBA AGUA
450-510	1	800078442	1	GIRANTE POMPA ACQUA	IMPELLER, WATER PUMP	TURBINE POMPE A EAU	WASSERPUMPE LAUFSCHWUNGRAD	ROTOR BOMBA AGUA
	2	800042278	1	DADO FLANGIATO M5X0,8	NUT FLANGE M5X0.8	ECROU BRIDE M5X0,8	GEFLANSCHTE MUTTER M5X0,8	TUERCA CON REBORDE M5X0,8
	3	800091564	1	CORPO POMPA ACQUA	CASE, WATER PUMP	CORPS POMPE A EAU	GEHAEUSE, WASSERPUMPE	CAJA BOMBA AGUA
	4	8000A4789	1	ALBERO POMPA ACQUA	SHAFT, WATER PUMP	ARBRE POMPE A EAU	WELLE, WASSERPUMPE	ARBOL, BOMBA AGUA
	5	161795501	2	BUSSOLA 8X6,4X6	BUSH 8X6.4X6	DOUILLE 8X6,4X6	BUCHSE 8X6,4X6	CASQUILLO 8X6,4X6
	6	800062730	3	VITE TE M6X1X30 CH8	SCREW TE M6X1X30 CH8	VIS TE M6X1X30 CH8	SCHRAUBE TE M6X1X30 CH8	TORNILLO TE M6X1X30 CH8
	7	800027122	1	ANELLO O-RING 3237 60X2,62	O-RING 3237 60X2.62	JOINT TORIQUE 3237 60X2,62	O-RING 3237 60X2,62	JUNTA TORICA 3237 60X2,62
	8	800091565	1	FLANGIA SUPPORTO POMPA ACQUA	FLANGE, WATER PUMP	BRIDE POMPE A EAU	FLANSCH, WASSERPUMPE	BRIDA BOMBA AGUA
	9	800034317	1	CUSCINETTO A SFERE 12X28X8	BEARING, BALL 12X28X8	ROULEMENT A BILLES 12X28X8	KUGELLAGER 12X28X8	COJINETE DE BOLAS 12X28X8
	10	800053339	1	PARAOLIO 8X16X10	OIL SEAL 8X16X10	BAGUE D'ETANCHEITE 8X16X10	WELLENDICHTRING 8X16X10	RETEN DE ACEITE 8X16X10
	11	800040007	1	ANELLO O-RING 2125	O-RING 2125	JOINT TORIQUE 2125	O-RING 2125	JUNTA TORICA 2125
250	12	800099708	1	TUBO ACQUA TESTA POMPA	HOSE-COOLING CYLINDER HEAD PUMP	TUYAU EAU COULASSE POMPE	WASSERLEITUNG ZYLINDERKOPF PUMPE	TUBO AGUA CULATA BOMBA
450-510	12	8A0099708	1	TUBO ACQUA TESTA POMPA	HOSE-COOLING CYLINDER HEAD PUMP	TUYAU EAU COULASSE POMPE	WASSERLEITUNG ZYLINDERKOPF PUMPE	MANGUERA AGUA CULATA BOMBA
	13	8B0099475	2	FASCETTA HOP 8-16/27 MM	CLAMP HOP 8-16/27 MM	COLLIER HOP 8-16/27 MM	SHELLE HOP 8-16/27 MM	ABRAZADERA HOP 8-16/27 MM
	14	800099659	1	RADIATORE SINISTRO TOYO	RADIATOR, LH TOYO	RADIATEUR GAUCHE TOYO	WASSERKUEHLER LINKS TOYO	RADIADOR IZQUERDO TOYO
	14	8000B1407	1	RADIATORE SINISTRO KTM	RADIATOR, LH KTM	RADIATEUR GAUCHE KTM	WASSERKUEHLER LINKS KTM	RADIADOR IZQUERDO KTM
	15	800099658	1	RADIATORE DESTRO TOYO	RADIATOR, RH TOYO	RADIATEUR DROIT TOYO	WASSERKUEHLER RECHTS TOYO	RADIADOR DERECHO TOYO
	15	8000B1406	1	RADIATORE DESTRO KTM	RADIATOR, RH KTM	RADIATEUR DROIT KTM	WASSERKUEHLER RECHTS KTM	RADIADOR DERECHO KTM
TC	16	8B0043715	1	TUBO SFIATO 660 MM	HOSE, BREATHER 660 MM	TUYAU RENIFLARD 660 MM	ENTLUEFTERSCHLAUCH 660 MM	MANGUERA RESPIRADERO 660 MM
	17	800056462	2	FASCETTA	CLAMP 11.5X6 MM	COLLIER 11,5X6 MM	KLAMMER 11,5X6 MM	ABRAZADERA 11,5X6 MM
	18	8E0043716	1	TUBO	HOSE	TUYAU	SCHLAUCH	MANGUERA
	19	800059803	6	SILENTBLOCK	RUBBER, RADIATOR MOUNTING	CAOUTCHOUC MONTAGE RADIATEUR	SCHWINGUNGSDAEMPFER, KUEHLER	CASQUILLO ELASTICO RADIADOR
	20	800059802	6	BOCCOLA	BUSH	DOUILLE	BUCHSE	BUJE
	21	800062728	6	VITE TEF M6X1X20 CH8	SCREW TEF M6X1X20 CH8	VIS TEF M6X1X20 CH8	SCHRAUBE TEF M6X1X20 CH8	TORNILLO TEF M6X1X20 CH8
	22	800059801	6	RONDELLA 22X6,5X1	WASHER 22X6.5X1	RONDELLE 22X6,5X1	SCHLEIBE 22X6,5X1	ARANDELA 22X6,5X1
250	23	8B0099660	1	TUBO ACQUA POMPA RACCORDO	HOSE-COOLING PUMP JOINT	TUYAU EAU POMPE RACCORD	SCHLAUCH, WASSER PUMP ANSCHLUSS	MANGUITO AGUA BOMBA EMPALME
450-510	23	8C0099660	1	TUBO ACQUA POMPA RACCORDO	HOSE-COOLING PUMP JOINT	TUYAU EAU POMPE RACCORD	SCHLAUCH, WASSER PUMP ANSCHLUSS	MANGUERA AGUA BOMBA EMPALME
	24	8A00A0669	1	TUBO ACQUA RADIATORE SINISTRO RACCORDO	HOSE-COOLING RADIATOR LH-JOINT	TUYAU EAU RADIATEUR GAUCHE-RACCORD	WASSERSCHLAUCH LINKER KUEHLER-ANSCHLUSS	MANGUERA AGUA RADIADOR IZQUERDO-RACOR
	25	8000B1610	1	TUBO ACQUA RADIATORE DESTRO RACCORDO	HOSE-COOLING RADIATOR RH-JOINT	TUYAU EAU RADIATEUR DROIT-RACCORD	WASSERSCHLAUCH RECHTER KUEHLER-ANSCHLUSS	MANGUERA AGUA RADIADOR DERECHO-RACOR
	26	8000A0671	1	RACCORDO A T	JOINT T	RACCORD EN T	T-FORMIGER ANSCHLUSS	EMPALME EN T
	27	800099661	1	TUBO ACQUA	HOSE, WATER	TUYAU EAU	SCHLAUCH, WASSER	MANGUERA AGUA
	28	8000A0779	1	TUBO ACQUA	HOSE, WATER	TUYAU EAU	SCHLAUCH, WASSER	MANGUERA AGUA

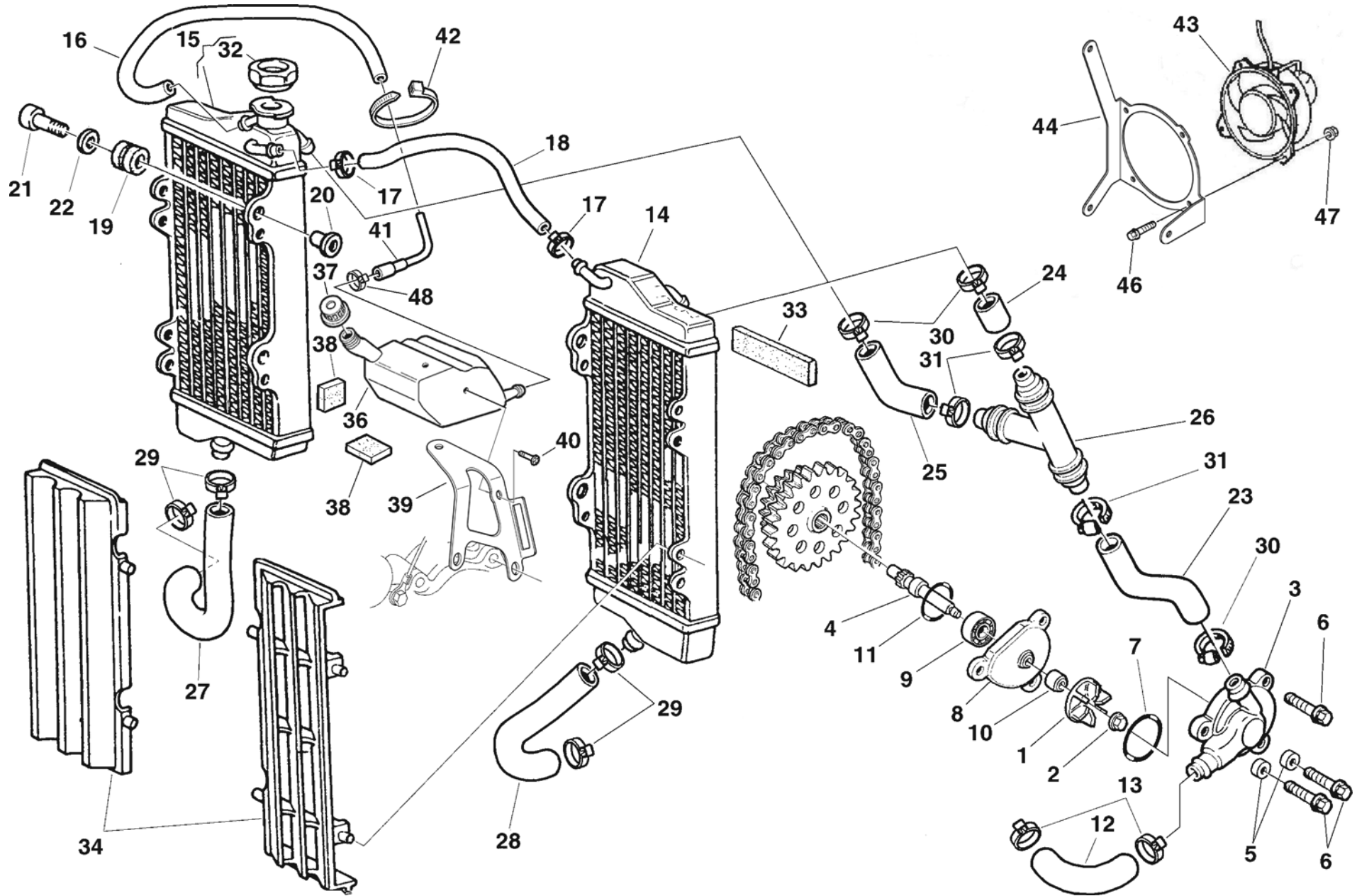



Note Notes Notes Marke Notas	Pos. No. N. Index Pos.	N. Cod. Code No. Nr. Code Code Nr N. Cod.	Q.tà Q.ty Q.te M.ge C.ad	DENOMINAZIONE	NAME	DESIGNATION	BESHREIBUNG	DENOMINACION
	29	8A0099475	4	FASCETTA HOP 8-12/22 MM	CLAMP HOP 8-12/22 MM	COLLIER HOP 8-12/22 MM	SCHELLE HOP 8-12/22 MM	ABRAZADERA HOP 8-12/22 MM
	30	8B0099475	3	FASCETTA HOP 8-16/27 MM	CLAMP HOP 8-16/27 MM	COLLIER HOP 8-16/27 MM	SCHELLE HOP 8-16/27 MM	ABRAZADERA HOP 8-16/27 MM
	31	800050453	3	FASCETTA 24,5 MM	CLAMP 24.5 MM	COLLIER 24,5 MM	SCHELLE 24,5 MM	ABRAZADERA 24,5 MM
	32	800079077	1	TAPPO RADIATORE ACQUA TOYO	CAP, RADIATOR TOYO	BOUCHON RADIATEUR TOYO	KUEHLERPROPFEN TOYO	TAPON RADIADOR TOYO
	32	8000A7991	1	TAPPO RADIATORE ACQUA KTM	CAP, RADIATOR KTM	BOUCHON RADIATEUR KTM	KUEHLERPROPFEN KTM	TAPON RADIADOR KTM
TE-SMR	33	800037140	1	TAMPONE ADESIVO	GROMMET ADHESIVE	CAOUTCHOUC ADHESIF	KLEBERGUMMI	GOMA ADHESIVA
	34	8AA0A0872	2	GRIGLIA RADIATORE	LOUVER, RADIATOR	GRILLE RADIATEUR	KHUELERGRILL	REJILLA RADIADOR
TE-SMR-TXC	36	8000B0612	1	VASO ESPANSIONE	TANK, WATER RESERVOIR	VASE EXPANSION	AUSDEHNGEFAESS	VASO EXPANSION
TE-SMR-TXC	37	800040427	1	TAPPO VASO ESPANSIONE	CAP, WATER RESERVOIR TANK	BOUCHON VASE EXPANSION	PFROPFEN, AUSDEHNGEFAESS	TAPON VASO EXPANSION
TE-SMR-TXC	38	800086004	2	TAMPONE ADESIVO	GROMMET ADHESIVE	CAOUTCHOUC ADHESIF	KLEBERGUMMI	GOMA ADHESIVA
TE-SMR-TXC	39	8000B0611	1	PIASTRINA	PLATE	PLAQUETTE	PLAETTCHEN	PLETINA
TE-SMR-TXC	40	8D0067997	2	VITE TE M5X0,8X8	SCREW TE M5X0.8X8	VIS TE M5X0,8X8	SCHRAUBE TE M5X0,8X8	TORNILLO TE M5X0,8X8
TE-SMR-TXC	41	8000A1281	1	TUBO	HOSE	TUYAU	SCHLAUCH	MANGUERA
	42	800056444	1	FASCETTA 188 MM	CLAMP 188 MM	COLLIER 188 MM	SCHELLE 188 MM	ABRAZADERA 188 MM
TE-SMR	43	8000A7715	1	ELETTOVENTOLA	BLOWER ASSY	ELECTRO-VENTILATEUR	ELEKTROLUEFTERRAD	ELECTROVENTILADOR
TE-SMR	44	8000B0257	1	SUPPORTO ELETTOVENTOLA	BRACKET ELECTRIC FAN	SUPPORT ELECTROVENTILATEUR	HALTER ELEKTROLUEFTER	SOPORTE VENTILADOR ELECTRICO
TE-SMR	46	60N101030	4	VITE TE M4X0,7X25	SCREW TE M4X0.7X25	VIS TE M4X0,7X25	SCHRAUBE TE M4X0,7X25	TORNILLO TE M4X0,7X25
TE-SMR	47	800040717	4	DADO FLANGIATO M4X0,7	NUT FLANGE M4X0.7	ECROU BRIDE M4X0,7	GEFLANSCHTE MUTTER M4X0,7	TUERCA CON REBORDE M4X0,7
TE-SMR	48	8B0091687	1	FASCETTA STRINGITUBO INOX D10	CLAMP, HOSE	COLLIER A VIS	SCHRAUBENSCHELLE	ABRAZADERA CON ROSCA

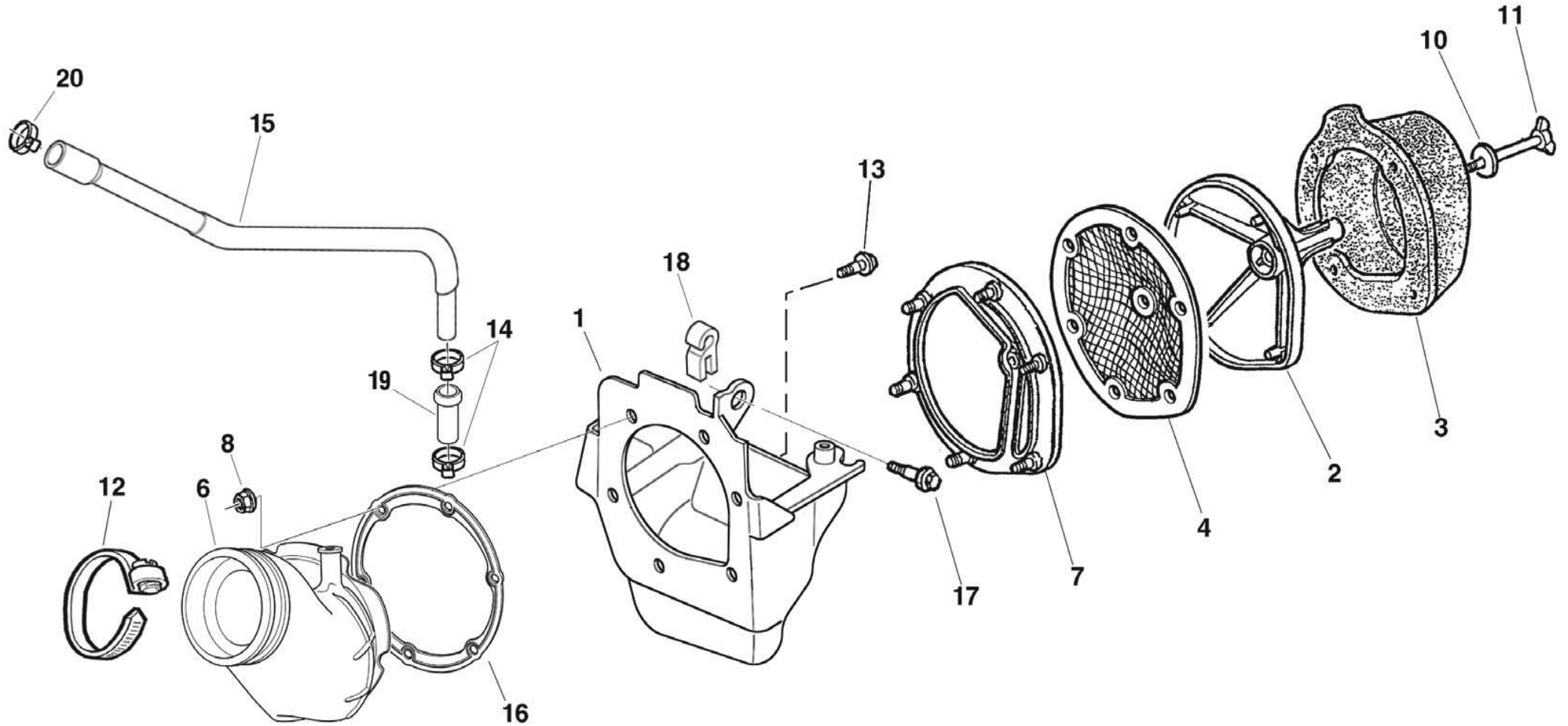

Note Notes Notes Marke Notas	Pos. No. N. Index Pos.	N. Cod. Code No. Nr. Code Code Nr N. Cod.	Q.tà Q.ty Q.te M.ge C.ad	DENOMINAZIONE	NAME	DESIGNATION	BESHREIBUNG	DENOMINACION
	1	8000B0247	1	CASSETTA FILTRO ARIA	CASE, AIR CLEANER	BOITE FILTRE A AIR	LUFTFILTERGEHAUSE	CAJA FILTRO AIRE
	2	800069549	1	GABBIA FILTRO ARIA	CAGE, AIR FILTER	CAGE FILTRE A AIR	LUFTFILTERKAEFIG	JAULA FILTRO AIRE
	3	800072641	1	FILTRO ARIA	FILTER, AIR	FILTRE A AIR	LUFTFILTER	FILTRO AIRE
	4	8000A0656	1	RETE PARAFIAMMA	ARRESTER, FLAME	RESEAU ANTIFLAMMES	FLAMMSCHUTZNETZ	RED ANTIFLAMA
SMR-TE	6	8000B0248	1	MANICOTTO CASSETTA FILTRO ARIA	TUBE, AIR CLEANER JOINT	RACCORD BOITE FILTRE A AIR	VERBINDUNGS, LUFTFILTERGEHAEUSE	MANGUITO, CAJA FILTRO AIRE
TC-TXC	6	8000B0444	1	MANICOTTO CASSETTA FILTRO ARIA	TUBE AIR CLEANER CONNECTING	TUBE DE RACCORD FILTRE A AIR	VERBINDUNGSROHR, LUFTFILTER	TUBO DE CONEXION, LIMPIADOR DE AIRE
	7	800070024	1	FLANGIA	FLANGE	BRIDE	FLANSCH	BRIDA
	8	800040718	6	DADO AUTOBLOCCANTE M5X0,8	NUT, SELF LOCKING M5X0.8	ECROU AUTOBLOQUANT M5X0,8	SELBSTSPERRENDE MUTTER M5X0,8	TUERCA AUTOBLOQUEANTE M5X0,8
	10	62N115549	1	RONDELLA 18X6,4X1	WASHER 18X6.4X1	RONDELLE 18X6,4X1	SCHEIBE 18X6,4X1	ARANDELA 18X6,4X1
	11	8A0037947	1	VITE A FARFALLA M6X1	SCREW, WING M6X1	VIS A OREILLES M6X1	FLUEGELSCHRAUBE M6X1	TORNILLO MARIPOSA M6X1
	12	8E0099475	1	FASCETTA NEMO 40/80 MM	CLAMP NEMO 40/80 MM	COLLIER NEMO 40/80 MM	SCHELLE NEMO 40/80 MM	ABRAZADERA NEMO 40/80 MM
	13	8B00A8421	2	VITE FLANGIATA M5X16	SCREW M5X14	VIS M5X16	SCHRAUBE M5X16	TORNILLO M5X16
	14	8M0092249	2	FASCETTA	CLAMP CLIC R96 14.5 MM	COLLIER CLIC R96 14,5 MM	KLAMMER CLIC R96 14,5 MM	ABRAZADERA CLIC R96 14,5 MM
	15	8000B0399	1	TUBO SFIATO	HOSE, BREATHER	TUYAU RENIFLARD	ENTLUEFTERSCHLAUCH	MANGUERA RESPIRADERO
	16	8000B0575	1	FLANGIA MANICOTTO CASSETTA FILTRO	HOLDER, GUIDE	PLAQUE AVANT BOITE FILTRE A AIR	PLATTE, LUFTFILTERGEHAEUSE	PLATINA SOPORTE JAULA FILTRO INTERIOR CO
	17	8A00A8421	1	VITE FLANGIATA M5X12	BOLT, FLANGE M5X12	VIS A EMBASE M5X12	GEFLANSCHSCHRAUBE M5X12	TORNILLO CON VALONA M5X12
TE-SMR	18	800072494	1	MOLLETTA FERMA CAVO	CLAMP, WIRE	COLLIER, CORDON	KABELBINDER	GRAMPA CORDON
	19	8000A8999	1	RACCORDO SFIATO	JOINT, BREATHER	RACCORD, RENIFLARD	ANSCHLUSS, BELUFTUNG	RACOR RESPIRADERO
	20	8A0092249	1	FASCETTA CLIC R 96-175 MM	HOSE CLAMP R 96-175 MM	COLLIER CLIC R 96-175 MM	SCHLAUCHSCHELLE R 96-175 MM	ABRAZADERA CLIC R 96-175 MM

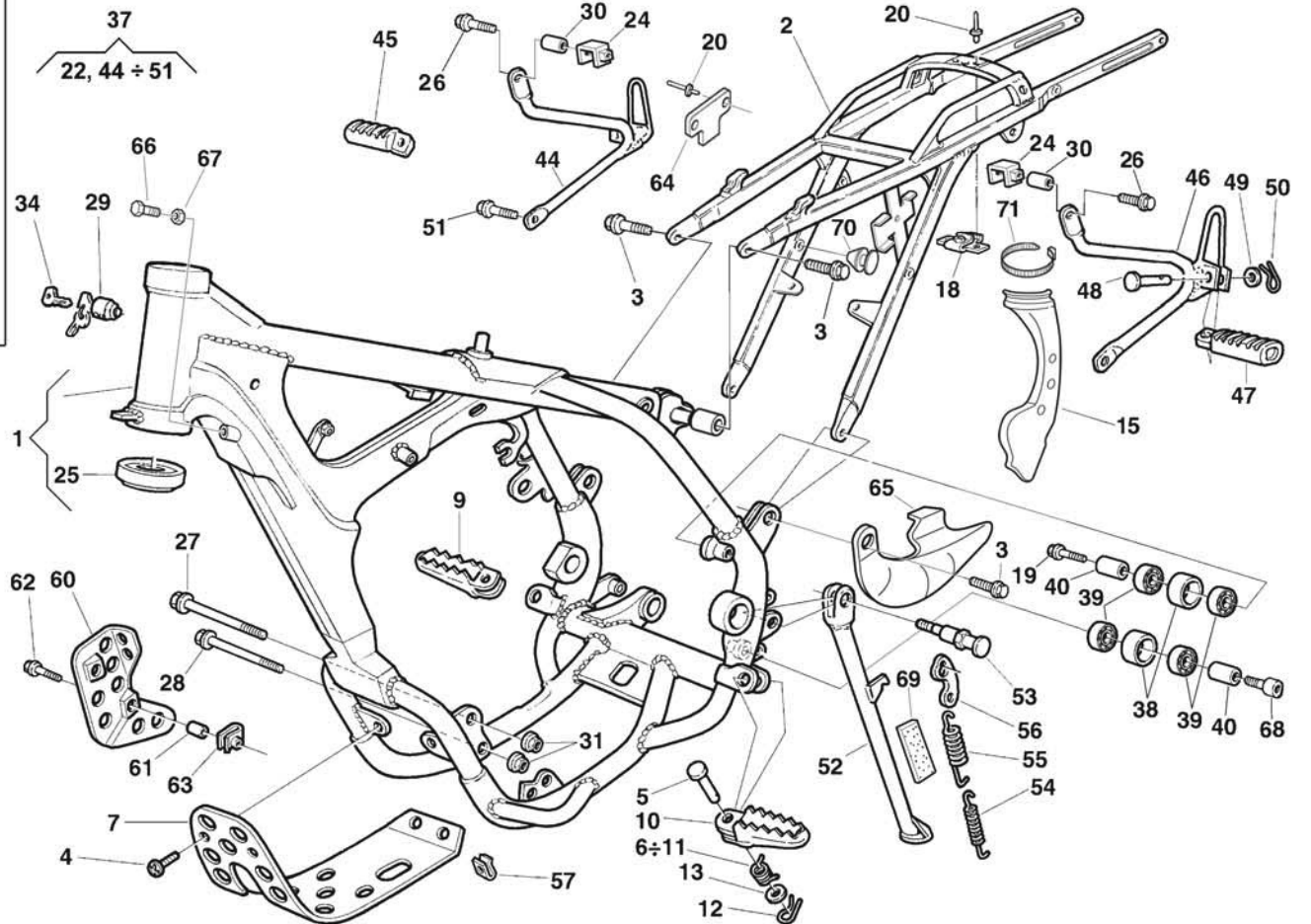
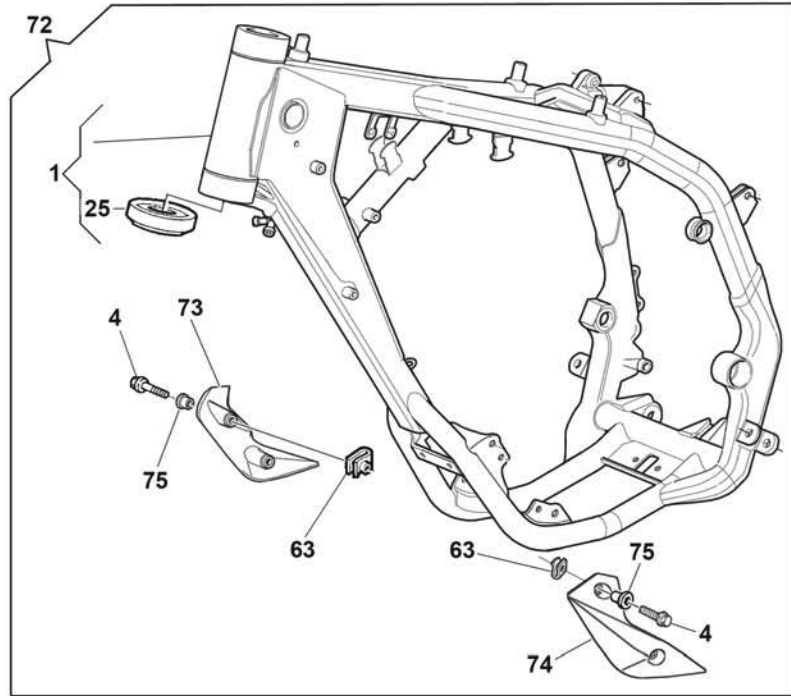

Note Notes Notes Marke Notas	Pos. No. N. Index Pos.	N. Cod. Code No. Nr. Code Code Nr N. Cod.	Q.tà Q.ty Q.te M.ge C.ad	DENOMINAZIONE	NAME	DESIGNATION	BESHREIBUNG	DENOMINACION
TC-TXC	1	8000H0186	1	TELAIO	FRAME	CADRE	RAHMEN	BASTIDOR
TE-SMR	1	8000H0231	1	TELAIO	FRAME	CADRE	RAHMEN	BASTIDOR
	2	8000B0214	1	TELAIO POSTERIORE	SUB FRAME	CADRE ARRIERE	AUSLEGER	BASTIDOR TRASERO
	3	800069056	4	VITE TE M8X1,25X20 CH12	SCREW TE M8X1.25X20 CH12	VIS TE M8X1,25X20 CH12	SCHRAUBE TE M8X1,25X20 CH12	TORNILLO TE M8X1,25X20 CH12
TE-TC	4	800060898	8	VITE TTEI M6X1,00X15	SCREW TTEI M6X1.00X15	VIS TTEI M6X1,00X15	SCHRAUBE TTEI M6X1,00X15	TORNILLO TTEI M6X1,00X15
	5	800073140	2	PERNO CLEVIS	PIN, CLEVIS	BOULON, A GOUPILLE	LASTOSENSTIFT	PASADOR CON HOYO
	6	800096907	1	MOLLA PEDANA SINISTRA	SPRING, FOOTREST LH	RESSORT REPOSE-PIEDS GAUCHE	FEDER, FUSSRASTE LINKS	MUELLE ESTRIBO IZQUERDO
	7	8000B0157	1	PARAMOTORE	GUARD, ENGINE	PROTECTION MOTEUR	SCHUTZ, MOTOR	PROTECCION MOTOR
	9	80A089953	1	PEDANA ANTERIORE DESTRA	FOOTREST, FRONT RH	REPOSE-PIEDS AVANT DROIT	VORNE FUSSRASTE, RECHTS	ESTRIBO DELANTERO DERECHO
	10	80A089962	1	PEDANA ANTERIORE SINISTRA	FOOTREST, FRONT LH	REPOSE-PIEDS AVANT GAUCHE	VERDER FUSSRASTE LINKS	ESTRIBO DELANTERO IZQUERDO
	11	800096908	1	MOLLA PEDANA DESTRA	SPRING, FOOTREST, RH	RESSORT REPOSE-PIEDS DROIT	FEDER, FUSSRASTE RECHTS	MUELLE ESTRIBO DERECHO
	12	64N120068	2	COPIGLIA 18X1,8	SPLIT PIN 18X1.8	GOUPILLE 18X1,8	SPLINT 18X1,8	CLAVIJA 18X1,8
	13	8A0001815	2	RONDELLA 16X10X1	WASHER 16X10X1	RONDELLE 16X10X1	SCHEIBE 16X10X1	ARANDELA 16X10X1
	15	80A0B0245	1	PROTEZIONE TELAIO SINISTRA	GUARD, FRAME LH	PROTECTION CADRE GAUCHE	RAHMENSCHUTZ LINKS	PROTECCION BASTIDOR IZQUERDA
	18	800069150	1	PIASTRINA ATTACCO SELLA	BRACKET, SEAT	SUPPORT SELLE	KONSOLE, SITZBANK	SOPORTE ASIENTO
	19	800062796	1	VITE TEF M8X1,25X40 CH12	SCREW TEF M8X1.25X40 CH12	VIS TEF M8X1,25X40 CH12	SCHRAUBE TEF M8X1,25X40 CH12	TORNILLO TEF M8X1,25X40 CH12
	20	800033373	4	RIVETTO A STRAPPO 3,3X14	SHEAR RIVET 3.3X14	RIVET ARRACHAGE 3,3X14	REISSNIETE 3,3X14	REMACHE A DESGARRE 3,3X14
TE-SMR	24	8000A7237	2	CAVALLOTTO	U-BOLT	CAVALIER	BUEGELBOLZEN	PUENTE
	25	800087243	2	CUSCINETTO A RULLI CONICI 29-48-17,5	CONICAL ROLLERS BEARING 29-48-17.5	ROULEMENT A ROULEAUX CONIQUES 29-48-17,5	KEGELROLLENLAGER 29-48-17,5	COJINETE DE RODILLOS CONICO 29-48-17,5
	26	800062796	4	VITE TEF M8X1,25X40 CH12	SCREW TEF M8X1.25X40 CH12	VIS TEF M8X1,25X40 CH12	SCHRAUBE TEF M8X1,25X40 CH12	TORNILLO TEF M8X1,25X40 CH12
	27	8G0073458	1	VITE M8X150	SCREW M8X150	VIS M8X150	SCHRAUBE M8X150	TORNILLO M8X150
	28	8G0073458	1	VITE M8X150	SCREW M8X150	VIS M8X150	SCHRAUBE M8X150	TORNILLO M8X150
TE-SMR	29	800043391	1	SERRATURA BLOCCASTERZO	LOCK, STEERING	ANTIVOL DIRECTION	SCHLOSS, LENKER	CARRADURA MANILLAR
	30	800024350	2	DISTANZIALE 18X8,5X19	SPACER 18X8.5X19	ENTRETOISE 18X8,5X19	ABSTANDHALTER 18X8,5X19	DISTANCIADOR 18X8,5X19
	31	800043928	3	DADO AUTOBLOCCANTE M8X1,25	NUT, SELF LOCKING M8X1.25	ECROU AUTOBLOQUANT M8X1,25	SELBSTSPERRENDE MUTTER M8X1,25	TUERCA AUTOBLOQUEANTE M8X1,25
TE-SMR	34	800035531	1	CHIAVE GREZZA	KEY, BLANK	CLE PAS CRANTEE	SCHLUSSEL NICHT GEZACKT	LLAVE SEMIACABADA
TE-SMR	37	8000B0152	1	KIT PEDANE PASSEGGERO	FOOTREST BRACKET KIT	GROUPE SUPPORT REPOSE PIEDS	FUSSRAESTERGRUPPE	GRUPO APOYAPIE TRASERO
	38	8AA059433	2	RULLO TENDICATENA	ROLLER, CHAIN TENSIONER	ROULEAU, TENDEUR CHAINE	ROLLE, KETTENSANNER	RODILLO, TENSIONADOR CADENA
	39	800063312	4	CUSCINETTO A SFERE 608 2RS	BEARING, BALL 608 2RS	ROULEMENT A BILLES 608 2RS	KUGELLAGER 608 2RS	COJINETE DE BOLAS 608 2RS
	40	8A0059434	2	DISTANZIALE	SPACER	ENTRETOISE	ABSTANDHALTER	DISTANCIADOR
TE-SMR	44	8000B0156	1	SUPPORTO PEDANA POSTERIORE DESTRA	BRACKET, PILLION FOOTREST RH	SUPPORT REPOSE-PIEDS ARRIERE DROIT	HINTERFUSSRASTENHALTER RECHTS	SOPORTE ESTRIBO TRASERO DERECHO
TE-SMR	45	800066652	1	PEDANA POSTERIORE DESTRA	FOOTREST, REAR RH	REPOSE-PIEDS ARRIERE DROIT	FUSSRASTE HINTEN, RECHTS	ESTRIBO TRASERO DERECHO
TE-SMR	46	8000B0155	1	SUPPORTO PEDANA POSTERIORE SINISTRA	BRACKET, PILLION FOOTREST LH	SUPPORT REPOSE-PIEDS ARRIERE GAUCHE	HINTERFUSSRASTENHALTER LINKS	SOPORTE ESTRIBO TRASERO IZQUERDO

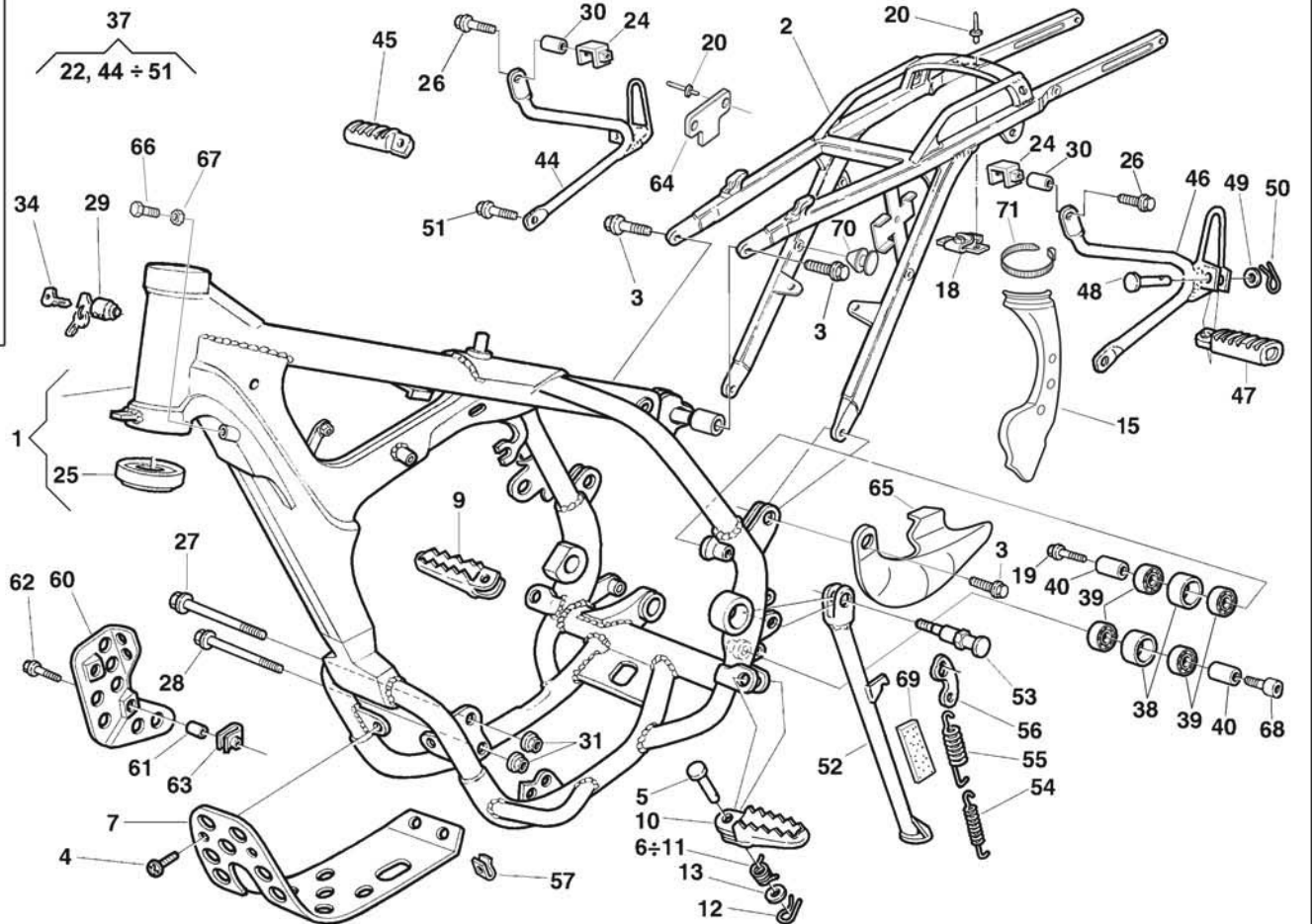
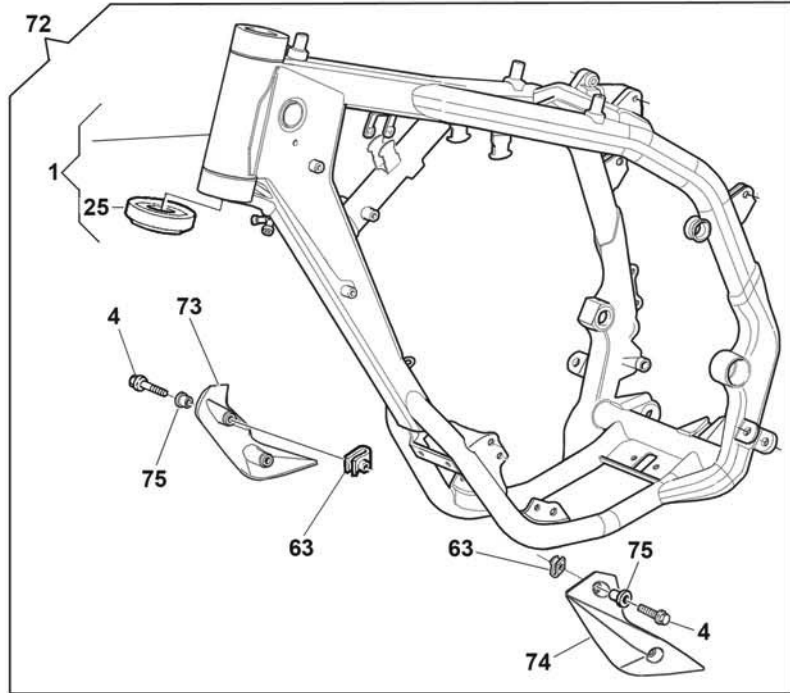

Note Notes Notes Marke Notas	Pos. No. N. Index Pos.	N. Cod. Code No. Nr. Code Code Nr N. Cod.	Q.tà Q.ty Q.te M.ge C.ad	DENOMINAZIONE	NAME	DESIGNATION	BESHREIBUNG	DENOMINACION
TE-SMR	47	800066651	1	PEDANA POSTERIORE SINISTRA	FOOTREST, REAR LH	REPOSE PIEDS ARRIERE GAUCHE	FUSSRASTE HINTEN , LINKS	ESTRIBO TRASERO IZQUERDO
TE-SMR	48	800041459	2	VITE	PIN, FOOTREST	PIVOT REPOSE-PIEDS	BOLZEN, FUSSREST	PERNO ESTRIBO
TE-SMR	49	62N115504	2	RONDELLA 12X6,4X1	WASHER 12X6.4X1	RONDELLE 12X6,4X1	SCHEIBE 12X6,4X1	ARANDELA 12X6,4X1
TE-SMR	50	64N120048	2	COPIGLIA 1,3X12	PIN, COTTER 1.3X12	GOUPILLE FENDUE 1,3X12	SPLINT 1,3X12	GRUPILLA 1,3X12
TE-SMR	51	800062732	2	VITE TEF M8X1,25X25 CH12	SCREW TEF M8X1.25X25 CH12	VIS TEF M8X1,25X25 CH12	SCHRAUBE TEF M8X1,25X25 CH12	TORNILLO TEF M8X1,25X25 CH12
SMR	52	8A00B0499	1	CAVALLETTO LATERALE	SIDE STAND	BEQUILLE LATERALE	KIPPSTAENDER	CABALLETE LATERAL
TE	52	8000B0499	1	CAVALLETTO LATERALE	SIDE STAND	BEQUILLE LATERALE	KIPPSTAENDER	CABALLETE LATERAL
TE-SMR	53	800097976	1	VITE M8X1,25X25	SCREW M8X1.25X25	VIS M8X1,25X25	SCHRAUBE M8X1,25X25	TORNILLO M8X1,25X25
TE-SMR	54	8000A0268	1	MOLLA CAVALLETTO LATERALE INTERNA	SPRING, SIDE STAND INNER	RESSORT INTERIEUR BEQUILLE LATERALE	INNEREFEDER, KIPPSTAENDERFEDER	MUELLE INTERIOR CABALLETE LATERAL
TE-SMR	55	8000A0269	1	MOLLA CAVALLETTO LATERALE ESTERNA	SPRING SIDE STAND OUTER	RESSORT EXTERIEUR BEQUILLE LATERALE	AUSSEREFEDER, SEITENSTAENDER	MUELLE EXTERIOR CABALLETE LATERAL
TE-SMR	56	8000A0267	1	PIASTRINA PORTAMOLLE CAVALLETTO	LINK, SIDE STAND	PLAQUETTE RESSORT BEQUILLE LATERALE	PLAETTCHEN STAENDERFEDER	PLACA MUELLE CABALLETE
TE-TC	57	800046893	4	DADO ELASTICO M6X1	CLIP NUT M6X1	JONC M6X1	KLEMME M6X1	PREASIENTO M6X1
TE-TC-TXC 250-450-510	60	8000A1427	1	PROTEZIONE CARTER DESTRO	GUARD. RH CRANKCASE	PROTECTION CARTER DROIT	SCHUTZ, RECHTER GEHAUSE	PROTECCION CARTER DERECHO
TE-TC	61	8A0067207	2	DISTANZIALE	SPACER	ENTRETOISE	ABSTANDHALTER	DISTANCIADOR
TE-TC	62	800062730	2	VITE TE M6X1X30 CH8	SCREW TE M6X1X30 CH8	VIS TE M6X1X30 CH8	SCHRAUBE TE M6X1X30 CH8	TORNILLO TE M6X1X30 CH8
TE-TC	63	800046893	6	DADO ELASTICO M6X1	CLIP NUT M6X1	JONC M6X1	KLEMME M6X1	PREASIENTO M6X1
	64	8000A6062	1	PIASTRINA	PLATE	PLAQUETTE	PLAETTCHEN	PLETINA
	65	8000B1747	1	ISOLANTE TERMICO	INSULATOR, HEAT	ISOLATEUR THERMIQUE	WAERMSCHUTZ	AISILANTE ATERMICO
	66	8E0061121	2	VITE M8X30	SCREW M8X30	VIS M8X30	SCHRAUBE M8X30	TORNILLO M8X30
	67	800017810	2	DADO M8X1,25	NUT M8X1.25	ECROU M8X1,25	MUTTER M8X1,25	TUERCA M8X1,25
	68	60N102559	1	VITE M8X40	SCREW M8X40	VIS M8X40	SCHRAUBE M8X40	TORNILLO M8X40
	69	8A0094356	1	TAMPONE CAVALLETTO	CUSHON, STAND STOPPER	TAMPON FIN COURSE BEQUILLE	ANSCHLAGSTOPFEN STAENDER	TACO FIN CARRERA CABALLETE
	70	8000B0841	1	TAPPO	PLUG	BOUCHON	VERSCHLUSS	TAPON
	71	800056444	1	FASCETTA 188 MM	CLAMP 188 MM	COLLIER 188 MM	SCHELLE 188 MM	ABRAZADERA 188 MM
TC-TXC	72	8000H0863	1	TELAIO COMPLETO	FRAME KIT	KIT CADRE	RAHMENGRUPPE	KIT BASTIDOR
TE	72	8000H0862	1	TELAIO COMPLETO	FRAME KIT	KIT CADRE	RAHMENGRUPPE	KIT BASTIDOR
TE-TC-TXC	73	8000H0188	1	PROTEZIONE CARTER DESTRO	GUARD. RH CRANKCASE	PROTECTION CARTER DROIT	SCHUTZ, RECHTER GEHAUSE	PROTECCION CARTER DERECHO
TE-TC-TXC	74	8000H0187	1	PROTEZIONE CARTER SINISTRO	GUARD, FRONT LH	PROTECTION CARTER GAUCHE	SCHUTZ, LINKER GEHAUSE	PROTECCION CARTER IZQUERDO
TE-TC-TXC	75	8000H0822	4	BOCCOLA	BUSH	DOUILLE	BUCHSE	BUJE

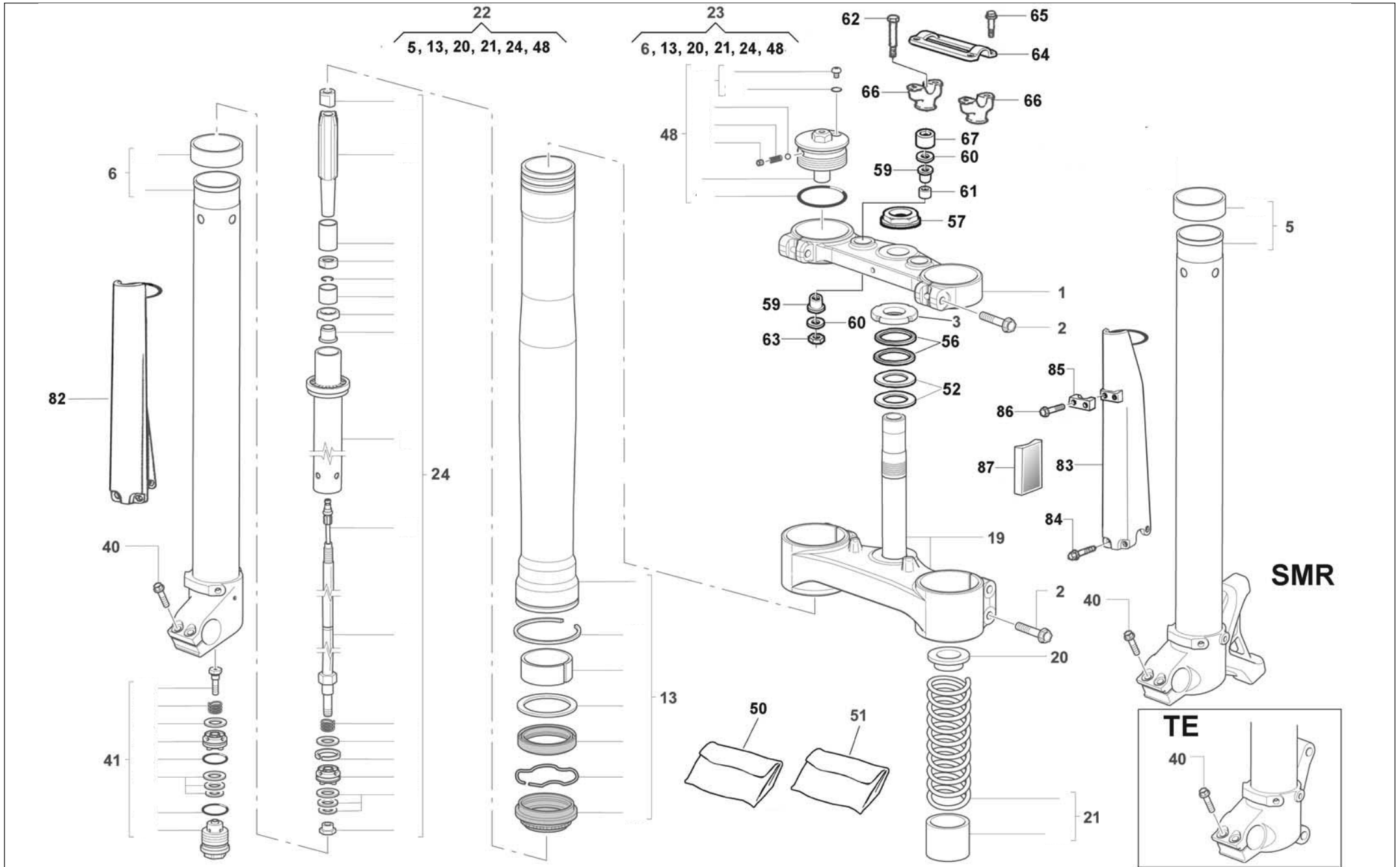





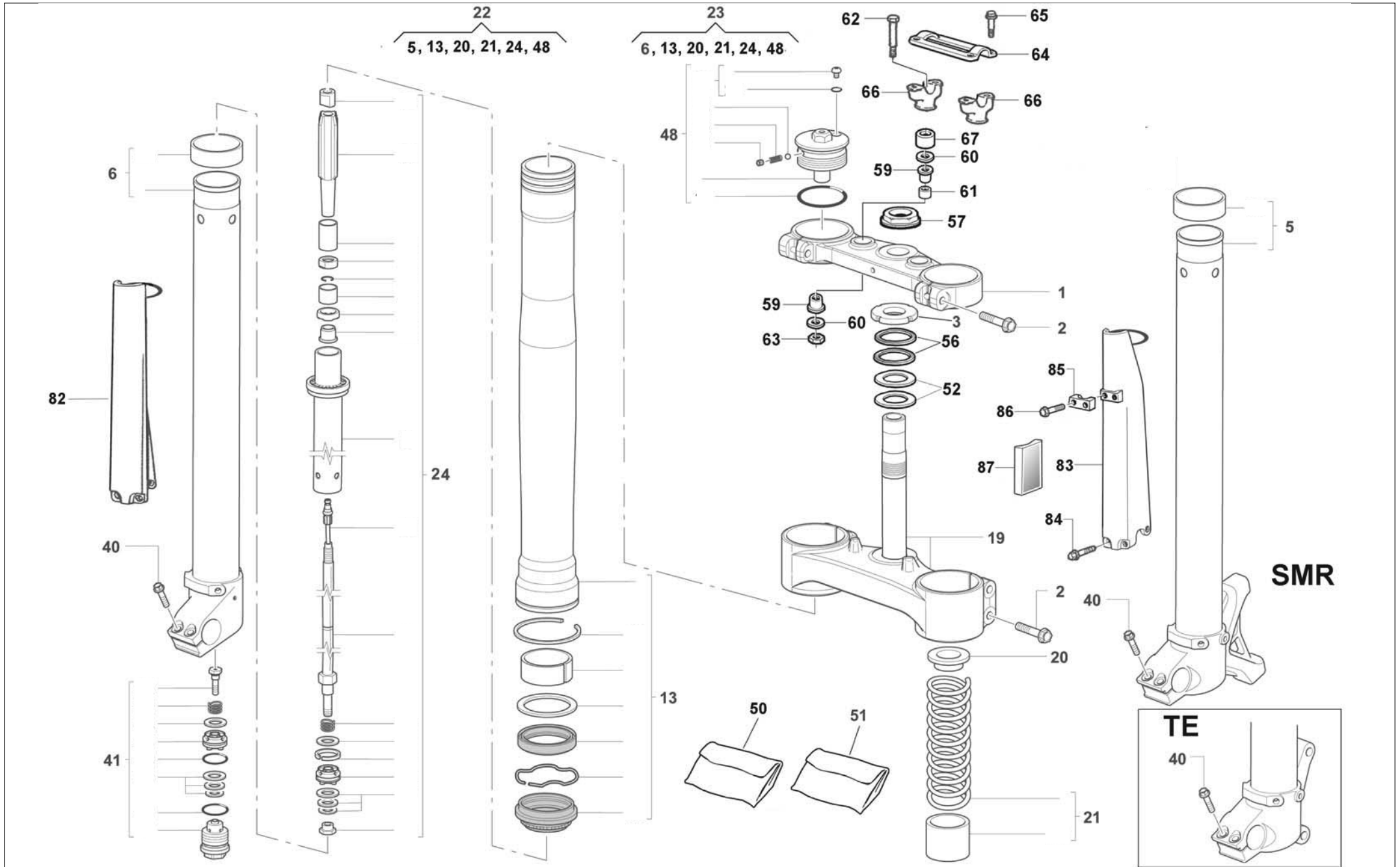



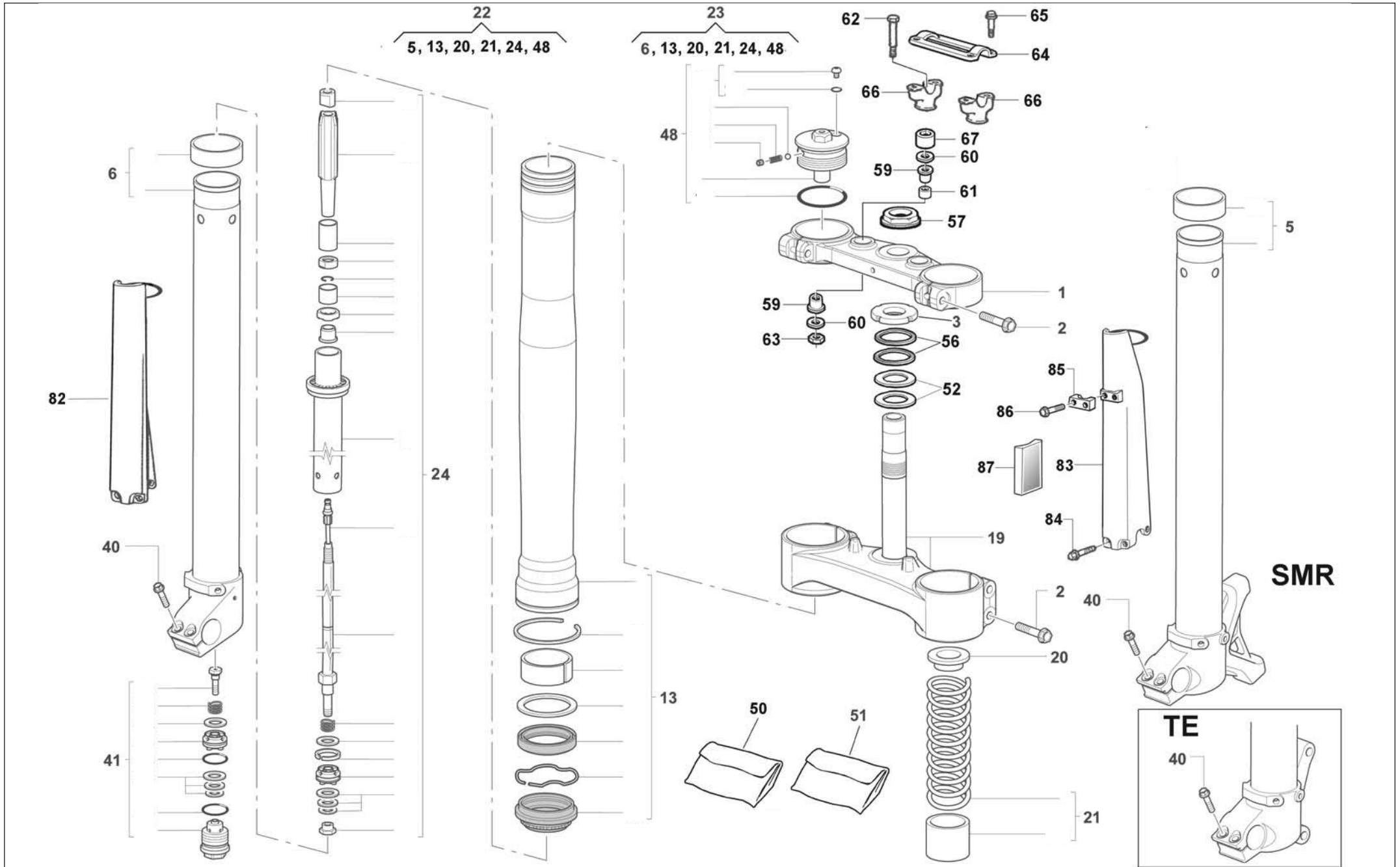



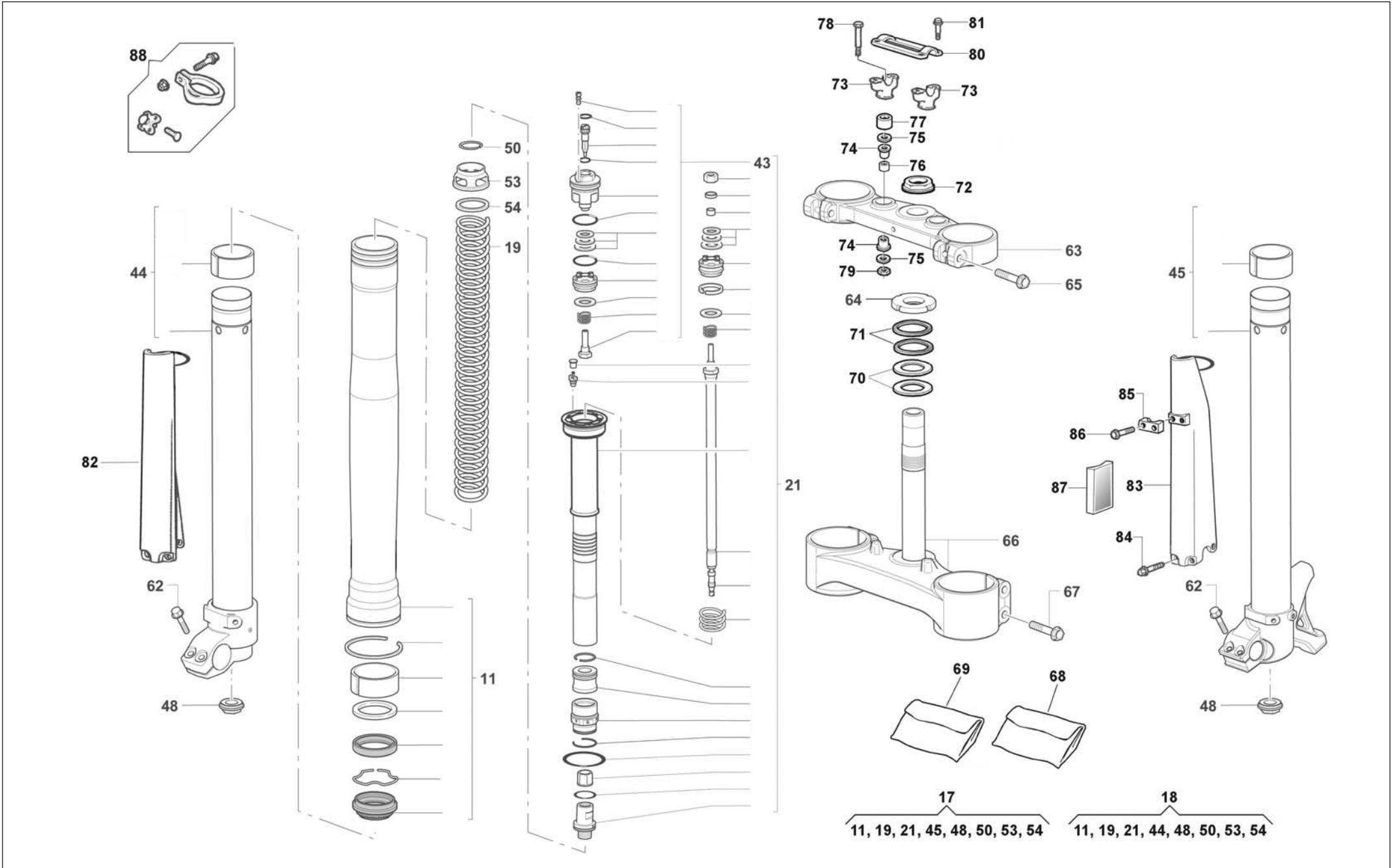

**SOSPENSIONE ANTERIORE - FRONT FORK ASSEMBLY  
 SUSPENSION AVANT - VORDERTELESKOPGABEL  
 SUSPENSION DELANTERA**

Note Notes Notas	Pos. No. N. Index Pos.	N. Cod. Code No. Nr. Code Code Nr N. Cod.	Q.tà Q.ty Q.te M.ge C.ad	DENOMINAZIONE	NAME	DESIGNATION	BESHREIBUNG	DENOMINACION
	11	80A0A7584	2	FODERO FORCELLA	FORK OUTER TUBE	FOURREAU FOURCHE	GABEL HUELSE	FUNDA HORQUILLA
250	17	8000B0441	1	GAMBA FORCELLA SINISTRA	FRONT FORK ASSY L.H.	FOURCHE COMPLETE GAUCHE	GABELBEIN, LINKS	HORQUILLA IZQUERDA
450-510	17	8A00B0441	1	GAMBA FORCELLA SINISTRA	FRONT FORK ASSY L.H.	FOURCHE COMPLETE GAUCHE	GABELBEIN, LINKS	HORQUILLA IZQUERDA
250	18	8000B0442	1	GAMBA FORCELLA DESTRA	FRONT FORK ASSY R.H.	FOURCHE COMPLETE DROIT	GABELBEIN, RECHTS	HORQUILLA DERECHA
450-510	18	8A00B0442	1	GAMBA FORCELLA DESTRA	FRONT FORK ASSY R.H.	FOURCHE COMPLETE DROIT	GABELBEIN, RECHTS	HORQUILLA DERECHA
250	19	8000B1690	2	MOLLA FORCELLA K=4,8 N/MM	SPRING FRONT FORK K=4.8 N/MM	RESSORT FOURCHE K=4,8 N/MM	FEDER, VORDERGABEL K=4,8 N/MM	MUELLE HORQUILLA DELANTERA K=4,8 N/MM
450-510	19	8000B1716	2	MOLLA FORCELLA K=5,0 N/MM	SPRING-FRONT FORK K=5.0 N/MM	RESSORT FOURCHE K=5,0 N/MM	FEDER, VORDERGABEL K=5,0 N/MM	MUELLE HORQUILLA DELANTERA K=5,0 N/MM
	21	8000B1691	2	POMPANTE FORCELLA	CYLINDER COMP. FRONT FORK	CARTUOCHE D'AMORTISSEMENT	DAEMPFUNGELEMENT	CARTUCHO DE AMORTIGUACION
	43	8000B1692	2	TAPPO FORCELLA	CAP	BOUCHON FOURCHE	VERSCHLUSS GABEL	TAPON HORQUILLA
	44	8000B1694	1	STELO FORCELLA DESTRO	FORK INNER TUBE RH	TIGE FOURCHE DROITE	GABELSTANGE, RECHTS	CANA HORQUILLA DERECHO
	45	8000B1693	1	STELO FORCELLA SINISTRO	FORK INNER TUBE LH	TIGE FOURCHE GAUCHE	GABELSTANGE, LINKS	CANA HORQUILLA IZQUERDO
	48	8000A7590	2	DADO	NUT	ECROU	MUTTER	TUERCA
	62	800062729	4	VITE TEF M6X1X25 CH8	SCREW TEF M6X1X25 CH8	VIS TEF M6X1X25 CH8	SCHRAUBE TEF M6X1X25 CH8	TORNILLO TEF M6X1X25 CH8
	63	8000B0220	1	PIASTRA FORCELLA SUPERIORE	HEAD, STEERING STEM	TETE DIRECTION	GABELKOPF	TIJA SUPERIOR
	64	8A0087717	1	GHIERA CANNOTTO	BOLT STEERING HEAD TOP	ECROU SUPERIEUR TETE DIRECTION	OBER-GEWINDE, STEUERKOPF	TUERCA SUPERIOR CABEZAL DIRECCION
	65	800062733	2	VITE TE M8X1,25X35 CH12	SCREW TE M8X1.25X35 CH12	VIS TE M8X1,25X35 CH12	SCHRAUBE TE M8X1,25X35 CH12	TORNILLO TE M8X1,25X35 CH12
	66	8000B0439	1	PIASTRA FORCELLA INFERIORE	STEM, STEERING	SOCLE DIRECTION	GABELBRUECKE, UNTEN	BASE DIRECCION
	67	800062796	4	VITE TEF M8X1,25X40 CH12	SCREW TEF M8X1.25X40 CH12	VIS TEF M8X1,25X40 CH12	SCHRAUBE TEF M8X1,25X40 CH12	TORNILLO TEF M8X1,25X40 CH12
	68	8000A7592	1	SERIE PARAPOLVERE E PARAOLIO	OIL SEAL SET	JEU BAGUES ETANCHEITE	DICHTRINGGRUPPE	JUEGO RETENES ACEITE
	69	8000A7593	1	SERIE BOCCOLE SCORRIMENTO	BUSH SET, SLIDE	JEU DOUILLE COULISSEMENT	GLEITBUCHSEGRUPPE	JUEGO CASQUILLO DESLIZAMIENTO
	70	800087745	2	GUARNIZIONE	GASKET	JOINT	DICHTUNG	JUNTA
	71	800087736	1	RONDELLA 40,5X29,5X2 MM	WASHER 40.5X29.5X2 MM	RONDELLE 40,5X29,5X2 MM	SCHEIBE 40,5X29,5X2 MM	ARANDELA 40,5X29,5X2 MM
	72	8A0069315	1	DADO CANNOTTO M26X1 CH30	NUT, STEERING STEM M26X1 CH30	ECROU FOURCHE M26X1 CH30	GABELMUTTER M26X1 CH30	TUERCA HORQUILLA M26X1 CH30
	73	8A00A5879	2	CAVALLOTTO MANUBRIO INFERIORE	HOLDER, HANDLE LOWER	BRIDE INFERIEUR GUIDON	HALTER, LENKER UNTEN	SOPORTE, INFERIOR MANILLAR
	74	800060233	4	SILENTBLOCK	DAMPER	SILENTBLOC	SCHWINGUNGSDAEMPFER	CASQUILLO ELASTICO
	75	800060234	2	RONDELLA 28X22X10,5X2,5 MM	WASHER 28X22X10.5X2.5 MM	RONDELLE 28X22X10,5X2,5 MM	SCHEIBE 28X22X10,5X2,5 MM	ARANDELA 28X22X10,5X2,5 MM
	76	800053155	2	DISTANZIALE 12X10,1X34	SPACER 12X10.1X34	ENTRETOISE 12X10,1X34	ABSTANDHALTER 12X10,1X34	DISTANCIADOR 12X10,1X34
	77	8A00A6683	2	DISTANZIALE 32X10X13,5 MM	SPACER 32X10X13.5 MM	ENTRETOISE 32X10X13,5 MM	ABSTANDHALTER 32X10X13,5 MM	DISTANCIADOR 32X10X13,5 MM
	78	60N101222	2	VITE TE M10X1,5X80	SCREW TE M10X1.5X80	VIS TE M10X1,5X80	SCHRAUBE TE M10X1,5X80	TORNILLO TE M10X1,5X80
	79	800061314	2	DADO AUTOBLOCCANTE M10X1,5	NUT, SELF LOCKING M10X1.5	ECROU AUTOBLOQUANT M10X1,5	SELBSTSPERRENDE MUTTER M10X1,5	TUERCA AUTOBLOQUEANTE M10X1,5
	80	8A00A4092	1	CAVALLOTTO MANUBRIO SUPERIORE	HOLDER, HANDLE UPPER	BRIDE SUPERIEUR	HALTER, OBEN	SOPORTE SUPERIOR
	81	8C0069056	4	VITE TEF M8X1,25X30 CH12	SCREW TEF M8X1.25X30 CH12	VIS TEF M8X1,25X30 CH12	SCHRAUBE TEF M8X1,25X30 CH12	TORNILLO TEF M8X1,25X30 CH12
BLACK	82	80A0A8482	1	PROTEZIONE STELO FORCELLA DESTRO	GUARD FORK TUBE, RH	PROTECTION TIGE FOURCHE DROITE	GABELSTANGENSCHUTZ RECHTS	PROTECCION VARILLA DERECHA

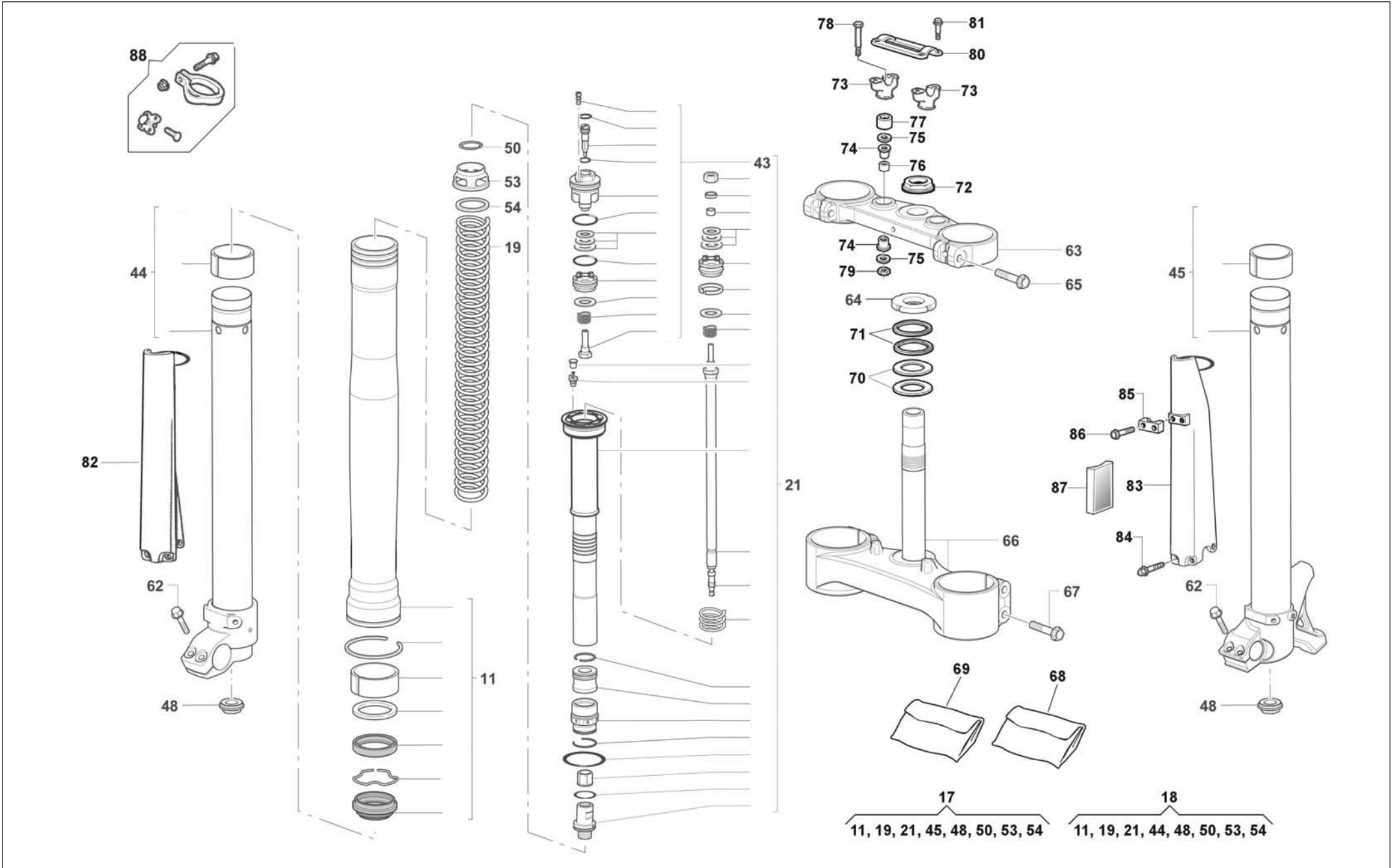





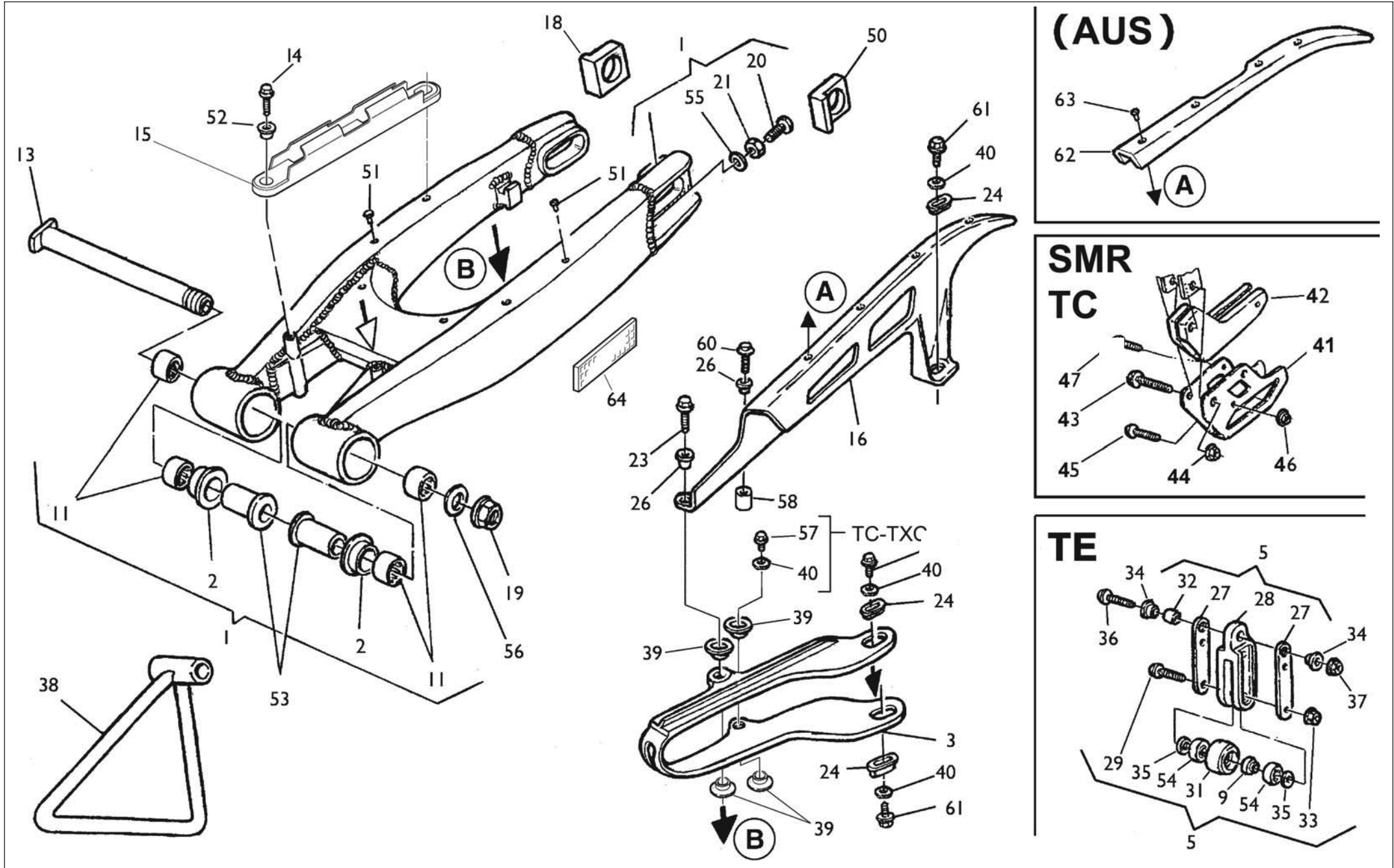

Note Notes Notas	Pos. No. N. Index Pos.	N. Cod. Code No. Nr. Code Code Nr N. Cod.	Q.tà Q.ty Q.te M.ge C.ad	DENOMINAZIONE	NAME	DESIGNATION	BESHREIBUNG	DENOMINACION
SMR	1	8A00B0228	1	FORCELLONE	REAR SWING ARM ASSY	BRAS OSCILLANT	HINTERE SCHWINGARM	BASCULANTE
TE-TC-TXC	1	8000B0228	1	FORCELLONE	REAR SWING ARM ASSY	BRAS OSCILLANT	HINTERE SCHWINGARM	BASCULANTE
	2	800071622	2	BOCCOLA FORCELLONE	BUSHING, SWING ARM	DOUILLE, BRAS OSCILLANT	HULSE, SCHWINGE	COLLAR BASCULANTE
	3	80A099619	1	PATTINO SCORRICATENA FORCELLONE	BUFFER, CHAIN TOUCH DEFENSE	PATIN PROTECTEUR BRAS OSCILLANT	KETTENGLEITFUEHRUNG	PATIN DESLIZAMIENTO CADENA
TE-SMR	5	800072873	1	CRUNA CATENA	GUIDE, CHAIN	GUIDE CHAINE	KETTENFUEHRUNG	GUIA CADENA
	9	800065412	1	DISTANZIALE 12X8,2X9	SPACER 12X8,2X9	ENTRETOISE 12X8,2X9	ABSTANDHALTER 12X8,2X9	DISTANCIADOR 12X8,2X9
	11	800076283	4	GABBIA A RULLI 22X28X11	BEARING, NEEDLE 22X28X11	ROULEMENT A AIGUILLES 22X28X11	NADELLAGER 22X28X11	COJINETE DE AGUJAS 22X28X11
	13	8A0071620	1	PERNO FORCELLONE	AXE REAR SWING ARM	AXE BRAS OSCILLANT	SCHWINGENACHSE	PERNO BASCULANTE
	14	800020536	2	VITE TE AUTOFILETTANTE 4,8X13	SCREW SELF-TAPPING 4.8X13	VIS TARAUD 4,8X13	GEWINDESCHRAUBE 4,8X13	TORNILLO AUTOROSCANTE 4,8X13
	15	8000B1166	1	GUIDA TUBO FRENO	CLAMP, BRAKE HOSE	GUIDE TUYAU FREIN	FUEHRUNG, BREMSSCHLAUCH	GUIA MANGUERA FRENO
TE-SMR	16	8AB073909	1	CARTER CATENA	GUARD, CHAIN	CARTER CHAINE	KETTENGEGAEUSE	CARTER CADENA
	18	800096944	1	TENDICATENA DESTRO	ADJUSTER, CHAIN RH	TENDEUR CHAINE DROIT	KETTENSPELLER RECHTS	TENSIONADOR CADENA DERECHO
	19	800071623	1	DADO FLANGIATO M16X1,5	NUT FLANGE M16X1.5	ECROU BRIDE M16X1,5	GEFLANSCHTE MUTTER M16X1,5	TUERCA CON REBORDE M16X1,5
	20	8C0061121	2	VITE TE M8X1,25	SCREW TE M8X1.25	VIS TE M8X1,25	SCHRAUBE TE M8X1,25	TORNILLO TE M8X1,25
	21	800017810	2	DADO M8X1,25	NUT M8X1.25	ECROU M8X1,25	MUTTER M8X1,25	TUERCA M8X1,25
TE-SMR	23	8A0067997	1	VITE TEF M5X0,8X16	SCREW TEF M5X0,8X16	VIS TEF M5X0,8X16	SCHRAUBE TEF M5X0,8X16	TORNILLO TEF M5X0,8X16
	24	800059289	3	SCODELLINO	CUP	COUPELLE	EINSTELLE	COPELA
TE-SMR	26	8A0069282	2	DISTANZIALE 14X7X5,25 MM	SPACER 14X7X5,25 MM	ENTRETOISE 14X7X5,25 MM	ABSTANDHALTER 14X7X5,25 MM	DISTANCIADOR 14X7X5,25 MM
	27	800072875	2	PIASTRINA	PLATE	PLAQUETTE	PLAETTCHEN	PLETINA
	28	800072874	1	GUIDACATENA	GUIDE, CHAIN	GUIDE CHAINE	KETTENFUEHRUNG	GUIA CADENA
	29	800062731	2	VITE TEF M6X1X45	SCREW TEF M6X1X45	VIS TEF M6X1X45	SCHRAUBE TEF M6X1X45	TORNILLO TEF M6X1X45
	31	800065411	1	RULLO TENDICATENA	ROLLER, CHAIN TENSIONER	ROULEAU, TENDEUR CHAINE	ROLLE, KETTENSPELLER	RODILLO, TENSIONADOR CADENA
	32	151550601	1	BOCCOLA	BUSH	DOUILLE	BUCHSE	BUJE
	33	800044240	2	DADO AUTOBLOCCANTE M6X1 CH10	NUT, SELF LOCKING M6X1 CH10	ECROU AUTOBLOQUANT M6X1 CH10	SELBSTSPERRENDE MUTTER M6X1 CH10	TUERCA AUTOBLOQUEANTE M6X1 CH10
	34	8A0066661	2	DISTANZIALE 20X12X8,5	SPACER 20X12X8,5	ENTRETOISE 20X12X8,5	ABSTANDHALTER 20X12X8,5	DISTANCIADOR 20X12X8,5
	35	800045495	2	BOCCOLA	BUSH	DOUILLE	BUCHSE	BUJE
	36	800062795	1	VITE TEF M8X1,25X50 CH12	SCREW TEF M8X1,25X50 CH12	VIS TEF M8X1,25X50 CH12	SCHRAUBE TEF M8X1,25X50 CH12	TORNILLO TEF M8X1,25X50 CH12
	37	800043928	1	DADO AUTOBLOCCANTE M8X1,25	NUT, SELF LOCKING M8X1,25	ECROU AUTOBLOQUANT M8X1,25	SELBSTSPERRENDE MUTTER M8X1,25	TUERCA AUTOBLOQUEANTE M8X1,25
TC-TXC	38	800074016	1	CAVALLETTO DI SERVIZIO	STAND	SUPPORT	STAENDER	CABALLETE
	39	800075166	4	SCODELLINO	CUP	COUPELLE	EINSTELLE	COPELA
	40	800036137	4	RONDELLA 11X5,5X1,5	WASHER 11X5,5X1,5	RONDELLE 11X5,5X1,5	SCHIBE 11X5,5X1,5	ARANDELA 11X5,5X1,5
TC	41	800072869	1	STAFFA CRUNA CATENA	PLATE, GUIDE CHAIN	EQUERRE GUIDE CHAINE	KONSOLE, KETTENFUEHRUNG	SOPORTE GUIA CADENA
TC	42	800072868	1	CRUNA CATENA	GUIDE, CHAIN	GUIDE CHAINE	KETTENFUEHRUNG	GUIA CADENA



Note Notes Notes Marke Notas	Pos. No. N. Index Pos.	N. Cod. Code No. Nr. Code Code Nr N. Cod.	Q.tà Q.ty Q.te M.ge C.ad	DENOMINAZIONE	NAME	DESIGNATION	BESHREIBUNG	DENOMINACION
TC	43	800062795	1	VITE TEF M8X1,25X50 CH12	SCREW TEF M8X1.25X50 CH12	VIS TEF M8X1,25X50 CH12	SCHRAUBE TEF M8X1,25X50 CH12	TORNILLO TEF M8X1,25X50 CH12
TC	44	800043928	1	DADO AUTOBLOCCANTE M8X1,25	NUT, SELF LOCKING M8X1.25	ECROU AUTOBLOQUANT M8X1,25	SELBSTSPERRENDE MUTTER M8X1,25	TUERCA AUTOBLOQUEANTE M8X1,25
TC	45	800062731	1	VITE TEF M6X1X45	SCREW TEF M6X1X45	VIS TEF M6X1X45	SCHRAUBE TEF M6X1X45	TORNILLO TEF M6X1X45
TC	46	800044240	1	DADO AUTOBLOCCANTE M6X1 CH10	NUT, SELF LOCKING M6X1 CH10	ECROU AUTOBLOQUANT M6X1 CH10	SELBSTSPERRENDE MUTTER M6X1 CH10	TUERCA AUTOBLOQUEANTE M6X1 CH10
TC	47	800062725	1	VITE TEF M6X1,00X10 CH8	SCREW TEF M6X1.00X10 CH8	VIS TEF M6X1,00X10 CH8	SCHRAUBE TEF M6X1,00X10 CH8	TORNILLO TEF M6X1,00X10 CH8
	50	800096941	1	TENDICATENA SINISTRO	ADJUSTER, CHAIN LH	TENDEUR CHAINE GAUCHE	KETTENSANNER LINKS	TENSIONADOR CADENA IZQUERDO
	51	800075160	5	RIVETTO	RIVET	RIVET	NIETE	REMACHE
	52	800069282	2	BOCCOLA 14X7X5,25 MM	BUSH 14X7X5.25 MM	DOUILLE 14X7X5,25 MM	BUCHSE 14X7X5,25 MM	CASQUILLO 14X7X5,25 MM
	53	800071621	1	BOCCOLA FORCELLONE 49,5 MM	COLLAR, SWINGARM 49.5 MM	DOUILLE, BRAS OSCILLANT 49,5 MM	BUCHSE, SCHWINGARM 49,5 MM	BUJE BASCULANTE 49,5 MM
	53	8A0071621	1	BOCCOLA FORCELLONE 58,5 MM	COLLAR, SWINGARM 58.5 MM	DOUILLE, BRAS OSCILLANT 58,5 MM	BUCHSE, SCHWINGARM 58,5 MM	BUJE BASCULANTE 58,5 MM
	54	800063312	2	CUSCINETTO A SFERE 608 2RS	BEARING, BALL 608 2RS	ROULEMENT A BILLES 608 2RS	KUGELLAGER 608 2RS	COJINETE DE BOLAS 608 2RS
	55	800008536	2	RONDELLA 13X8,4X2	WASHER 13X8.4X2	RONDELLE 13X8,4X2	SCHEIBE 13X8,4X2	ARANDELA 13X8,4X2
	56	800032388	1	RONDELLA 26X17,2X1,5	WASHER 26X17.2X1.5	RONDELLE 26X17,2X1,5	SCHEIBE 26X17,2X1,5	ARANDELA 26X17,2X1,5
	57	800067997	2	VITE TEF M5X0,8X12	SCREW TEF M5X0.8 CH8	VIS TEF M5X0,8 CH8	SCHRAUBE TEF M5X0,8 CH8	TORNILLO TEF M5X0,8 CH8
TE-SMR	58	800097025	1	BOCCOLA	BUSH	DOUILLE	BUCHSE	BUJE
TE-SMR	60	8G0067977	1	VITE M5X35	SCREW M5X35	VIS M5X35	SCHRAUBE M5X35	TORNILLO M5X35
	61	800020536	3	VITE TE AUTOFILETTANTE 4,8X13	SCREW SELF-TAPPING 4.8X13	VIS TARAUD 4,8X13	GEWINDESCHRAUBE 4,8X13	TORNILLO AUTOROSCANTE 4,8X13
TE-SMR AUS	62	8000A2352	1	PROLUNGA GUIDACATENA	EXTENSION, CHAIN GUIDE	RALLONGE GUIDE CHAINE	VERLAENGERUNG, KETTEFUEHERUNG	PROLONGACION GUIA CADENA
TE-SMR AUS	63	800081628	4	VITE AUTOFILETTANTE AB 2,9X6,5	SCREW SELF-TAPPING AB 2.9X6.5	VIS TARAUD AB 2,9X6,5	GEWINDESCHRAUBE AB 2,9X6,5	TORNILLO AUTOROSCANTE AB 2,9X6,5
CAN	64	800073832	2	CATADIOTTRO LATERALE	REFLEX REFLECTOR, SIDE	CATADIOPTRE LATERAL	SEITENRUECKSTRAHLER	CATAFARO LATERAL

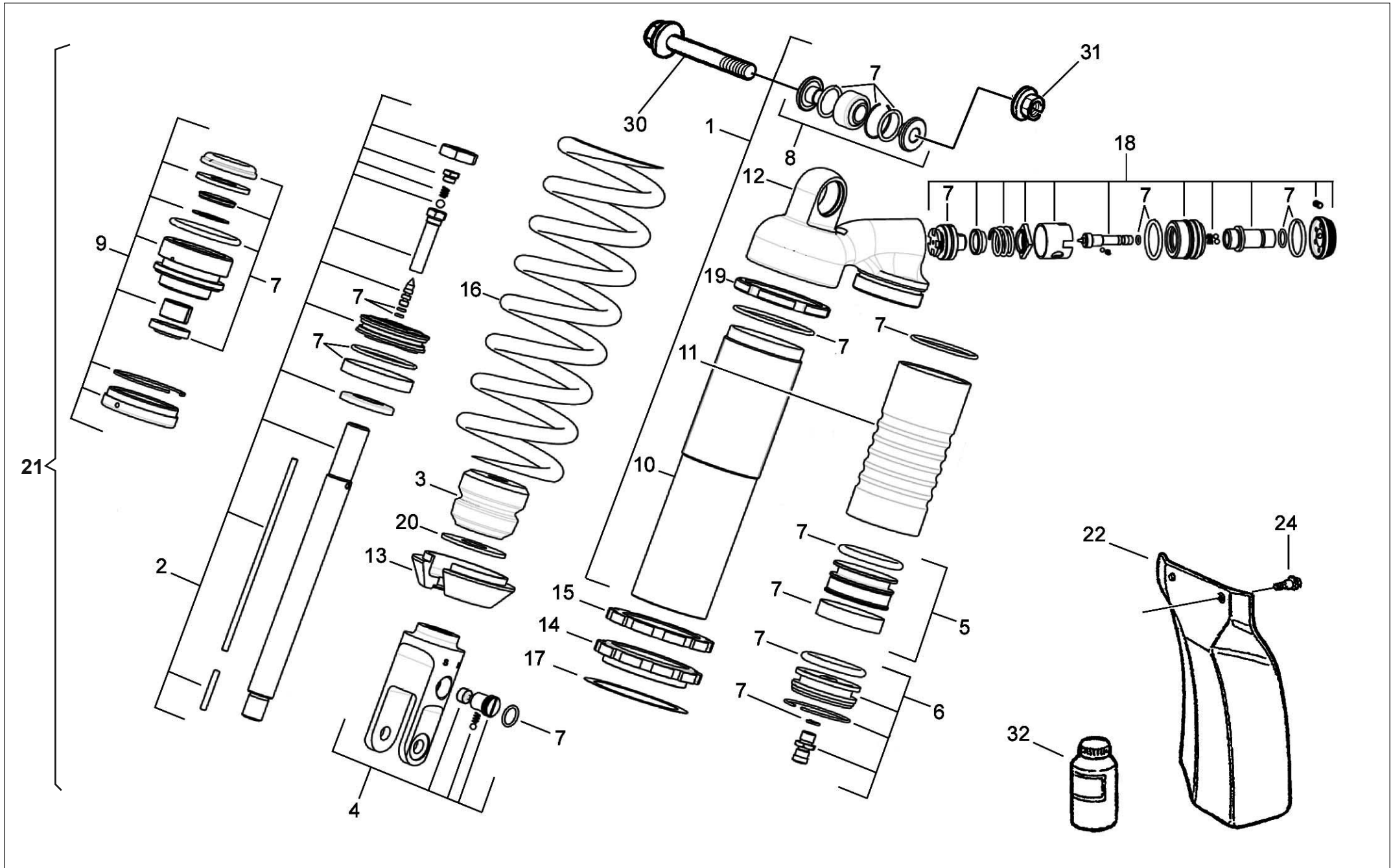

Note Notes Notas	Pos. No. N. Index Pos.	N. Cod. Code No. Nr. Code Code Nr N. Cod.	Q.tà Q.ty Q.te M.ge C.ad	DENOMINAZIONE	NAME	DESIGNATION	BESHREIBUNG	DENOMINACION
SMR	1	8000A5065	1	CORPO AMMORTIZZATORE POSTERIORE	DAMPER COMP., REAR	GROUPE CORPS AMORTISSEUR	STOSSDAEMPFERKOERPER	CORPO AMORTIGUADOR
TE-TC-TXC	1	8000H0069	1	CORPO AMMORTIZZATORE POSTERIORE	DAMPER COMP., REAR	GROUPE CORPS AMORTISSEUR	STOSSDAEMPFERKOERPER	CORPO AMORTIGUADOR
SMR	2	8000H0081	1	STELO AMMORTIZZATORE	ROD, SHOCKABSORBER	TIGE AMORTISSEUR	STANGE, FEDERBEIN	VARILLA AMORTIGUADOR
TC-TXC 250	2	8000H0079	1	STELO AMMORTIZZATORE	ROD, SHOCKABSORBER	TIGE AMORTISSEUR	STANGE, FEDERBEIN	VARILLA AMORTIGUADOR
TC-TXC 450-510	2	8000H0080	1	STELO AMMORTIZZATORE	ROD, SHOCKABSORBER	TIGE AMORTISSEUR	STANGE, FEDERBEIN	VARILLA AMORTIGUADOR
TE 250	2	8000H0078	1	STELO AMMORTIZZATORE	ROD, SHOCKABSORBER	TIGE AMORTISSEUR	STANGE, FEDERBEIN	VARILLA AMORTIGUADOR
TE 450-510	2	8000H0070	1	STELO AMMORTIZZATORE	ROD, SHOCKABSORBER	TIGE AMORTISSEUR	STANGE, FEDERBEIN	VARILLA AMORTIGUADOR
	3	8000A6670	1	TAMPONE FINE CORSA	SPINDLE, TAPER	CAOUTCHOUC BUTEE	ANSCHLAGGUMMI	GOMA, TAQUE
	4	8000H0071	1	FORCHETTA AMMORTIZZATORE	FORK	FOURCHETTE	GABEL	HORQUILLA
	5	8000A5071	1	DIAFRAMMA	DIAPHRAGM	DIAPHRAGME	MEMBRAN	MEMBRANA
	6	800098491	1	TAPPO	CAP	BOUCHON	CAP	TAPON
	7	8000H0072	1	GRUPPO REVISIONE AMMORTIZZATORE	OVERHAUL SET, REAR SHOCK ABSORBER	GROUPE REVISION AMORTISSEUR ARRIERE	HINTER FEDERBEIN EBERHOLUNGSSATZ	GRUPO REVISION AMORTIGUEADOR TRASERO
	8	800089089	1	BOCCOLA AMMORTIZZATORE	BUSH, DAMPER	BAGUE AMORTISSEUR	BUCHSE, FEDERBEIN	BUJE, AMORTIGUADO
	9	8000H0073	1	GRUPPO GUIDA STELO	CASE, ROD GUIDE	GROUPE GUIDE TIGE	PUMPENSTUECKFUHRUNGGRUPPE	GRUPO GUIA ESPIGA
	10	8000H0074	1	CORPO AMMORTIZZATORE	DAMPER COMP., REAR	GROUPE CORPS AMORTISSEUR	STOSSDAEMPFERKOERPER	CORPO AMORTIGUADOR
	11	8000B1920	1	SERBATOIO AMMORTIZZATORE	TANK, SHOCK ABSORBER	RESERVOIR, AMORTISSEUR	TANK, FEDERBEIN	DEPOSITO AMORTIGUADOR
	12	8000H0075	1	SUPPORTO SERBATOIO	BRACKET, TANK	SUPPORT RESERVOIR	HALTERUNG, TANK	SOPORTE DEPOSITO
	13	800098496	1	FONDELLO	CUP	GODET	DECKEL	CAZOLETA
	14	800098497	1	GHIERA	RING NUT	ECROU A BAGUE	RINGMUTTER	VIROLA
	15	800098498	1	CONTROGHIERA	RING NUT	ECROU A BAGUE	RINGMUTTER	VIROLA
250	16	800098504	1	MOLLA AMMORTIZZATORE K=5,4 KG/MM	SPRING, SHOCK ABSORBER K=5.4 KG/MM	RESSORT, AMORTISSEUR K=5,4 KG/MM	FEDER HINTERER FEDERBEIN K=5,4 KG/MM	MUELLE AMORTIGUADOR K=5,4 KG/MM
SMR	16	800098520	1	MOLLA AMMORTIZZATORE K=6,4 KG/MM	SPRING, SHOCK ABSORBER K=6.4 KG/MM	RESSORT, AMORTISSEUR K=6,4 KG/M	FEDER HINTERER FEDERBEIN K=6,4 KG/MM	MUELLE AMORTIGUADOR K=6,4 KG/MM
TE-TC-TXC 450-510	16	8000H0076	1	MOLLA AMMORTIZZATORE K=5,6 KG/MM	SPRING SHOCK ABSORBER K=5.6 KG/MM	RESSORT, AMORTISSEUR K=5,6 KG/MM	FEDER HINTERER FEDERBEIN K=5,6 KG/MM	MUELLE AMORTIGUADOR K=5,6 KG/MM
	17	800098499	1	RONDELLA	WASHER	RONDELLE	SCHEIBE	ARANDELA
	18	8000B1922	1	GRUPPO REGOLAZIONE AMMORTIZZATORE	ADJUSTER SET, SHOCK ABSORBER	GROUPE REGLAGE AMORTISSEUR ARRIERE	REGLERGRUPPE, HINTER FEDERBEIN	GRUPO REGULACION AMORTIGUEADOR TRASERO
	19	8000B1923	1	GHIERA	RING NUT	ECROU A BAGUE	RINGMUTTER	VIROLA
	20	8000H0077	1	RONDELLA	WASHER	RONDELLE	SCHEIBE	ARANDELA
SMR	21	8000B0666	1	AMMORTIZZATORE POSTERIORE	SHOCK ABSORBER, REAR	AMORTISSEUR ARRIERE	HINTERER FEDERBEIN	AMORTIGUADOR TRASERO
TC-TXC 250	21	8000B0443	4	AMMORTIZZATORE POSTERIORE	REAR SHOCK ABSORBER	AMORTISSEUR ARRIERE	HINTERER FEDERBEIN	AMORTIGUADOR TRASERO
TC-TXC 450-510	21	8000B0460	4	AMMORTIZZATORE POSTERIORE	REAR SHOCK ABSORBER	AMORTISSEUR ARRIERE	HINTERER FEDERBEIN	AMORTIGUADOR TRASERO
TE 250	21	8000B0242	1	AMMORTIZZATORE POSTERIORE	SHOCK ABSORBER, REAR	AMORTISSEUR ARRIERE	HINTERER FEDERBEIN	AMORTIGUADOR TRASERO
TE 450-510	21	8000B0276	1	AMMORTIZZATORE POSTERIORE	SHOCK ABSORBER, REAR	AMORTISSEUR ARRIERE	HINTERER FEDERBEIN	AMORTIGUADOR TRASERO
	22	800069551	1	PROTEZIONE AMMORTIZZATORE	COVER, SHOCK ABSORBER	PROTECTION AMORTISSEUR	SCHUTZ, FEDERBEIN	PROTECCION AMORTIGUADOR TRASERO

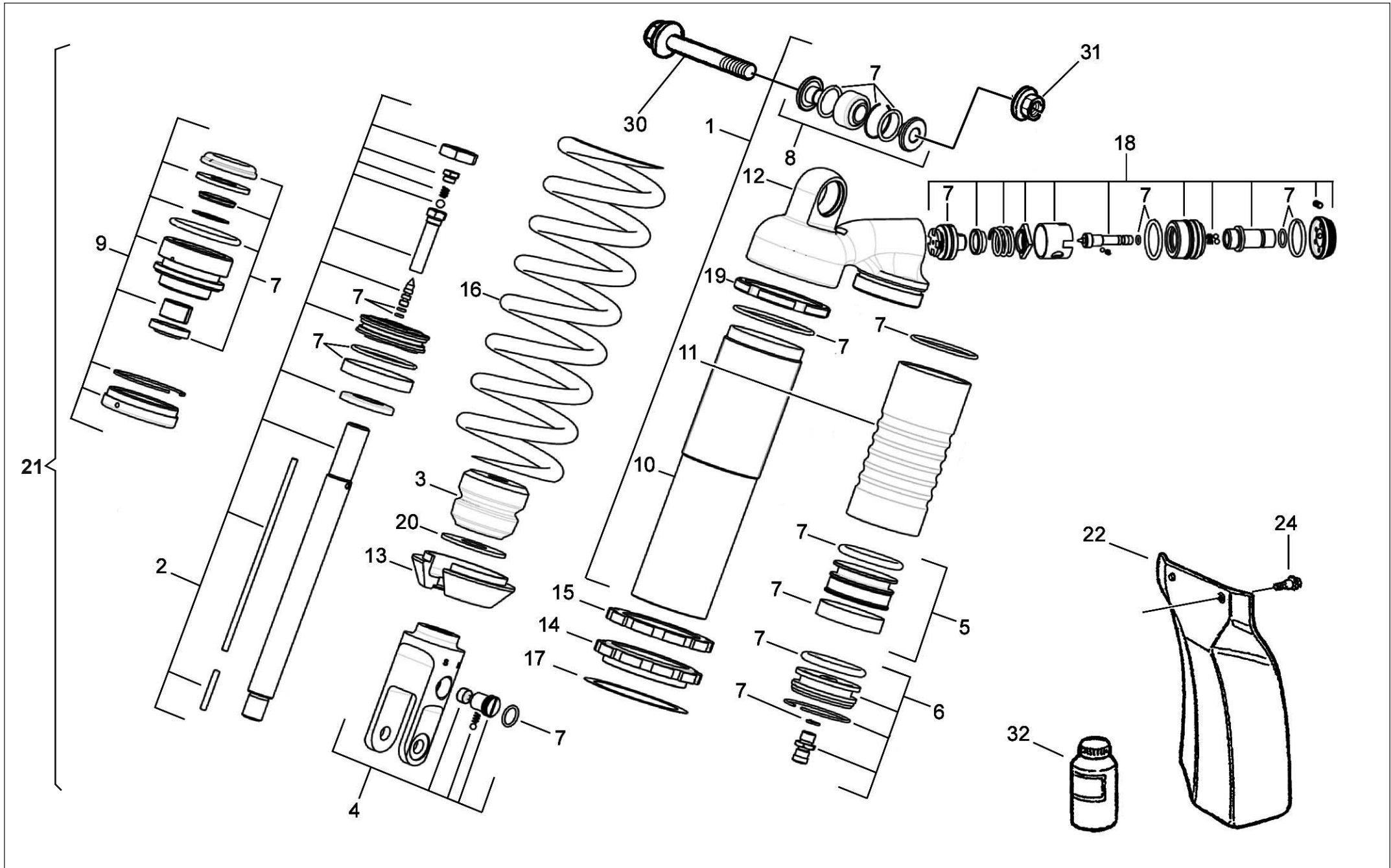





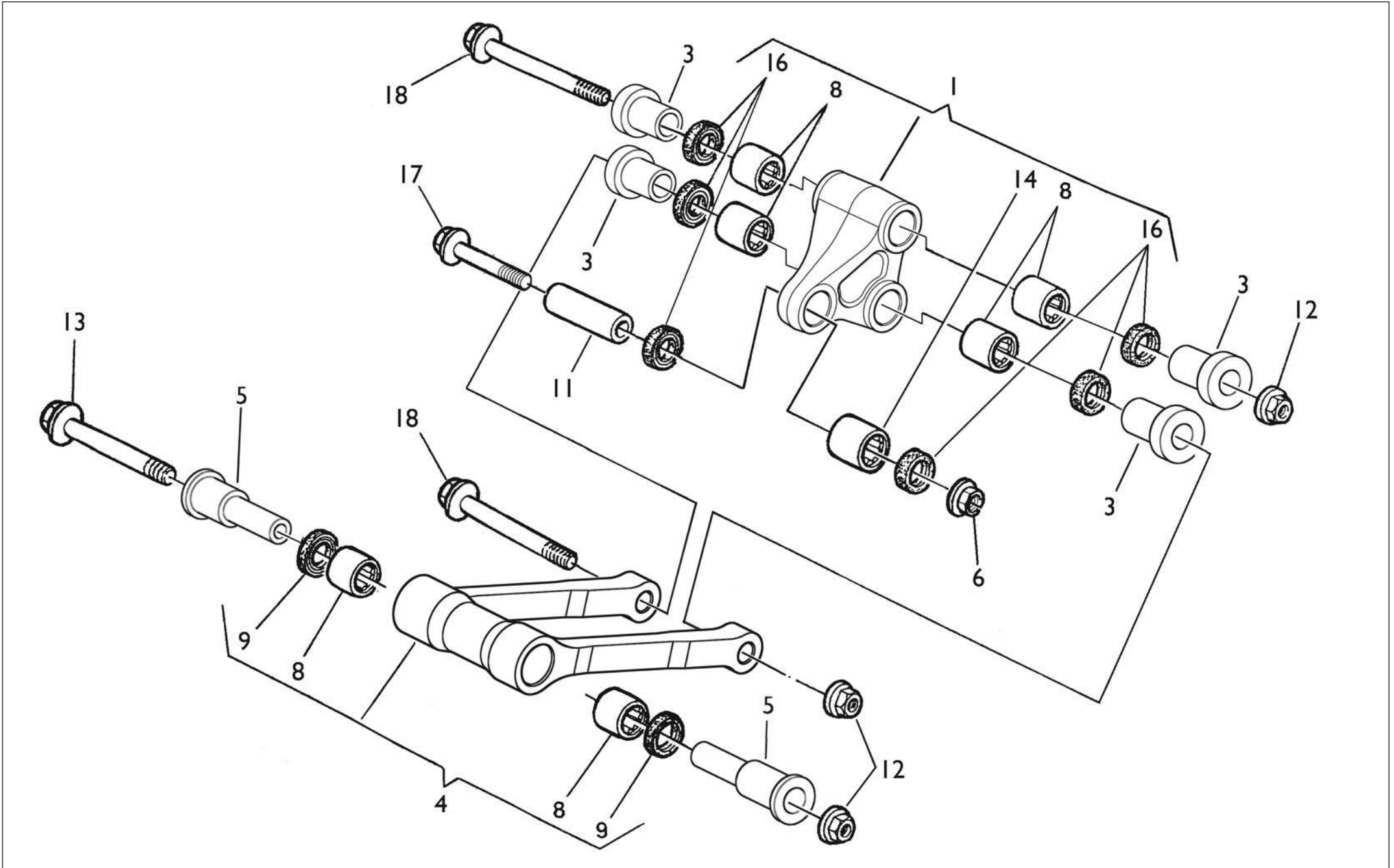

Note Notes Notes Marke Notas	Pos. No. N. Index Pos.	N. Cod. Code No. Nr. Code Code Nr N. Cod.	Q.tà Q.ty Q.te M.ge C.ad	DENOMINAZIONE	NAME	DESIGNATION	BESHREIBUNG	DENOMINACION
	1	8000B0239	1	BILANCIERE SOSPENSIONE POSTERIORE	SWINGARM, CUSHION RELAY	CULBUTEUR SUSPENSION ARRIERE	KIPPSCHWINGE, HINTEN FEDERUNG	BRAZO SUSPENSION TRASERO
	3	8000B0288	4	SPINOTTO	PIN	GOUJON	BOLZEN	EJE
	4	8000B0236	1	BIELLA SOSPENSIONE POSTERIORE	ARM RELAY, REAR CUSHION LEVER	BIELLE SUSPENSION ARRIERE	PLEUELSTANGE HINTEN FEDERUNG	BIELA SUSPENSION TRASERA
	5	8000B0241	2	SPINOTTO	PIN	GOUJON	BOLZEN	EJE
	6	800042022	1	DADO M10X1,25	NUT M10X1.25	ECROU M10X1,25	MUTTER M10X1,25	TUERCA M10X1,25
	8	800042781	6	ASTUCCIO A RULLI HK2020	BEARING, NEEDLE HK2620	ROULEMENT A AIGUILLES HK2620	NADELLAGER HK2620	COJINETE DE AGUJAS HK2620
	9	800032065	2	PARAOLIO 26X20X4	SEAL, OIL 26X20X4	BAGUE D'ETANCHEITE 26X20X4	WELLENDICHTRING 26X20X4	RETEN ACEITE 26X20X4
	11	8000A4431	1	SPINOTTO 20X10X25,2	WRIST PIN 20X10X25.2	GOUJON 20X10X25,2	BOLZEN 20X10X25,2	PASADOR 20X10X25,2
	12	800042023	3	DADO FLANGIATO M12X1,25	NUT FLANGE M12X1.25	ECROU BRIDE M12X1,25	GEFLANSCHTE MUTTER M12X1,25	TUERCA CON REBORDE M12X1,25
	13	8000B0240	1	VITE M12X122	SCREW M12X122	VIS M12X122	SCHRAUBE M12X122	TORNILLO M12X122
	14	800032064	1	ASTUCCIO A RULLI HK2016	BEARING, NEEDLE HK2016	ROULEMENT A AIGUILLES HK2016	NADELLAGER HK2016	COJINETE DE AGUJAS HK2016
	16	800032065	6	PARAOLIO 26X20X4	SEAL, OIL 26X20X4	BAGUE D'ETANCHEITE 26X20X4	WELLENDICHTRING 26X20X4	RETEN ACEITE 26X20X4
	17	8D0062797	1	VITE TE M10X1,25X47 CH14	SCREW TE M10X1.25X47 CH14	VIS TE M10X1,25X47 CH14	SCHRAUBE TE M10X1,25X47 CH14	TORNILLO TE M10X1,25X47 CH14
	18	8A00B0240	2	VITE M12X103	SCREW M12X103	VIS M12X103	SCHRAUBE M12X103	TORNILLO M12X103

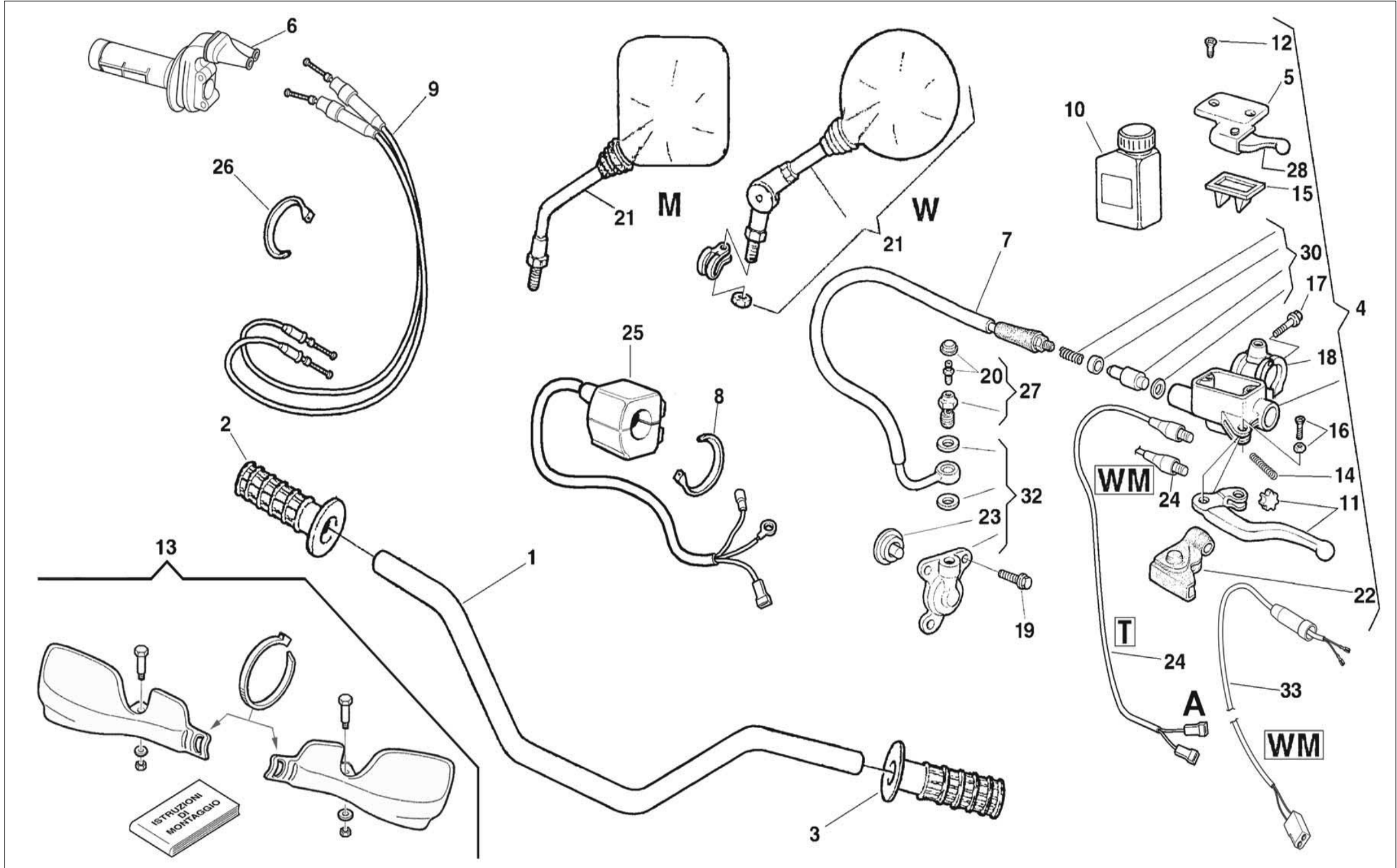

Note Notes Notas	Pos. No. Index Pos.	N. Cod. Code No. Nr. Code Code Nr N. Cod.	Q.tà Q.ty Q.te M.ge C.ad	DENOMINAZIONE	NAME	DESIGNATION	BESHREIBUNG	DENOMINACION
	1	80B0A3612	1	MANUBRIO	HANBLEBAR	GUIDON	LENKER	MANILLAR
	2	8000A6056	1	MANOPOLA DESTRA	HAND GRIP RH	POIGNEE DROIT	HANDGRIFF RECHTS	PUNO DERECHO
	3	8000A6057	1	MANOPOLA SINISTRA	HAND GRIP LH	POIGNEE GAUCHE	HANDGRIFF LINKS	PUNO IZQUERDO
TC-TXC	4	8B00A2836	1	POMPA FRIZIONE	CLUTCH MASTER CYLINDER	MAITRE-CYLINDRE EMBRAYAGE	KUPPLUNGSHAUPTZYLINDER	BOMBA EMBRAGUE
TE-SMR	4	8C00A2836	1	POMPA FRIZIONE	CLUTCH MASTER CYLINDER	MAITRE-CYLINDRE EMBRAYAGE	KUPPLUNGSHAUPTZYLINDER	BOMBA EMBRAGUE
	5	8000A2840	1	COPERCHIO VASCHETTA LIQUIDO FRENI	COVER MASTER CYLINDER	COUVERCLE RESERVOIR LIQUIDE FREIN	VERSCHLUSS BREMSFLUESSIGKEITANK	TAPON DEPOSITO LIQUIDO FRENOS
	6	800098209	1	COMANDO GAS	GRIP, THROTTLE	COMMANDE GAZ	GASSCHALTUNG	MANDO ACELERADOR
	7	8000A2841	1	TUBO OLIO FRIZIONE	HOSE, CLUTCH OIL	TUYAU HUILE EMBRAYAGE	KUPPLUNGSSTEUERUNGSSCHLAUCH	MANGUERA MANDO EMBRAGUE
TC-TXC	9	8000A4630	1	CAVO GAS	CABLE, THROTTLE	CABLE GAZ	GASSEIL	CABLE ACELERADOR
TE-SMR	9	8000B1927	1	CAVO GAS	CABLE, THROTTLE	CABLE GAZ	GASSEIL	CABLE ACELERADOR
	10	8000A0878	1	OLIO FRIZIONE	CLUTCH OIL	HUILE EMBRAYAGE	KUPPLUNG OEL	ACEITE EMBRAGUE
	11	8000A2837	1	LEVA FRIZIONE	LEVER, CLUTCH	LEVIER EMBRAYAGE	KUPPLUNGSHEBEL	PALANCA EMBRAGUE
	12	8000A0055	2	VITE M4X12 DIN 965	SCREW M4X12 DIN 965	VIS M4X12 DIN 965	SCHRAUBE M4X12 DIN 965	TORNILLO M4X12 DIN 965
TE	13	80A0A6211	1	KIT PARAMANI	HAND-GUARD SET	COUPLE PROTEGE-MAINS	HANDSCHUTZPAAR	PAREJA GUARDAMANOS
	14	8000A3408	1	MOLLA	SPRING	RESSORT	FEDER	MUELLE
	15	8000A0913	1	MEMBRANA	DIAPHRAGM	DIAPHRAGME	MEMBRAN	MEMBRANA
	16	8000A0877	1	VITE LEVA	BOLT, LEVER	VIS LEVIER	SCHRAUBE, HEBEL	TORNILLO PALANCA
	17	800062728	1	VITE TEF M6X1X20 CH8	SCREW TEF M6X1X20 CH8	VIS TEF M6X1X20 CH8	SCHRAUBE TEF M6X1X20 CH8	TORNILLO TEF M6X1X20 CH8
TC-TXC	18	8000A0939	1	CAVALLOTTO POMPA	HOLDER-BRAKE, MASTER CYLINDER	BRIDE MAITRE CYLINDRE	KONSOLE, HAUPTBREMSZYLINDER	PUNTE BOMBA FRENO
TE-SMR	18	8A00A0939	1	CAVALLOTTO POMPA	HOLDER-BRAKE, MASTER CYLINDER	BRIDE MAITRE CYLINDRE	KONSOLE, HAUPTBREMSZYLINDER	PUNTE BOMBA FRENO
	19	800062727	3	VITE TE M6X1X16 CH8	SCREW TE M6X1X16 CH8	VIS TE M6X1X16 CH8	SCHRAUBE TE M6X1X16 CH8	TORNILLO TE M6X1X16 CH8
	20	8000A3410	1	VALVOLA SPURGO	VALVE, BREATHER	SOUPAPE VIDANGE	VENTIL ENTLUEFTUNGS	VALVULA PURGA
SMR	21	8B0068934	1	SPECCHIO DESTRO	MIRROR, RH	MIROIR DROIT	SPIEGEL RECHTS	ESPEJO DERECHO
SMR	21	8C0068934	1	SPECCHIO SINISTRO	MIRROR, LEFT	MIROIR GAUCHE	SPIEGEL LINKS	ESPEJO IZQUERDO
TE	21	800065437	2	SPECCHIO	MIRROR	MIROIR	SPIEGEL	ESPEJO
	22	8000A0915	1	SOFFIETTO LEVA FRIZIONE	BOOT,CLUTCH LEVER	SOUFFLET EN CAOUTCHOUC	SCHUTZKAPPE	FUELLE GOMA
	23	8000A3409	1	PISTONCINO DISINNESTO FRIZIONE	PISTON, CLUTCH RELEASE	PISTON DEGAGEMENT EMBRAYAGE	KOLBEN, KUPPLUNG AUSLOESER	PISTON DESEMBRAGUE
TE-SMR	24	8000A4134	1	INTERRUTTORE FRIZIONE	SWITCH, CLUTCH	INTERRUPTEUR EMBRAYAGE	KUPPLUNGSSCHALTER	INTERRUPTOR EMBRAGUE
TXC	24	8000A4457	1	INTERRUTTORE FRIZIONE	SWITCH, CLUTCH	INTERRUPTEUR EMBRAYAGE	KUPPLUNGSSCHALTER	INTERRUPTOR EMBRAGUE
TE-SMR	25	8000A6779	1	COMMUTATORE LUCI DESTRO	HANDLE SWITCH, RH	COMMUTATEUR FEUX DROITE	RECHTER LICHTSCHALTER	CONMUTADOR LUCES DERECHO
	26	800071578	4	FASCETTA 78 MM	CLAMP 78 MM	COLLIER 78 MM	SHELLE 78 MM	ABRAZADERA 78 MM
	27	8000A5705	1	VITE SPURGO	SCREW, BLEED	VIS VIDANGE	SCHRAUBE, ABLASS	TORNILLO PURGA
	28	8000A9207	1	LEVA ALZAVOLVILE	LEVER, VALVE LIFTER	LEVIER DECOMPRESSEUR	DEKOMPRESSIONS HEBEL	PALANCA DECOMPRESION

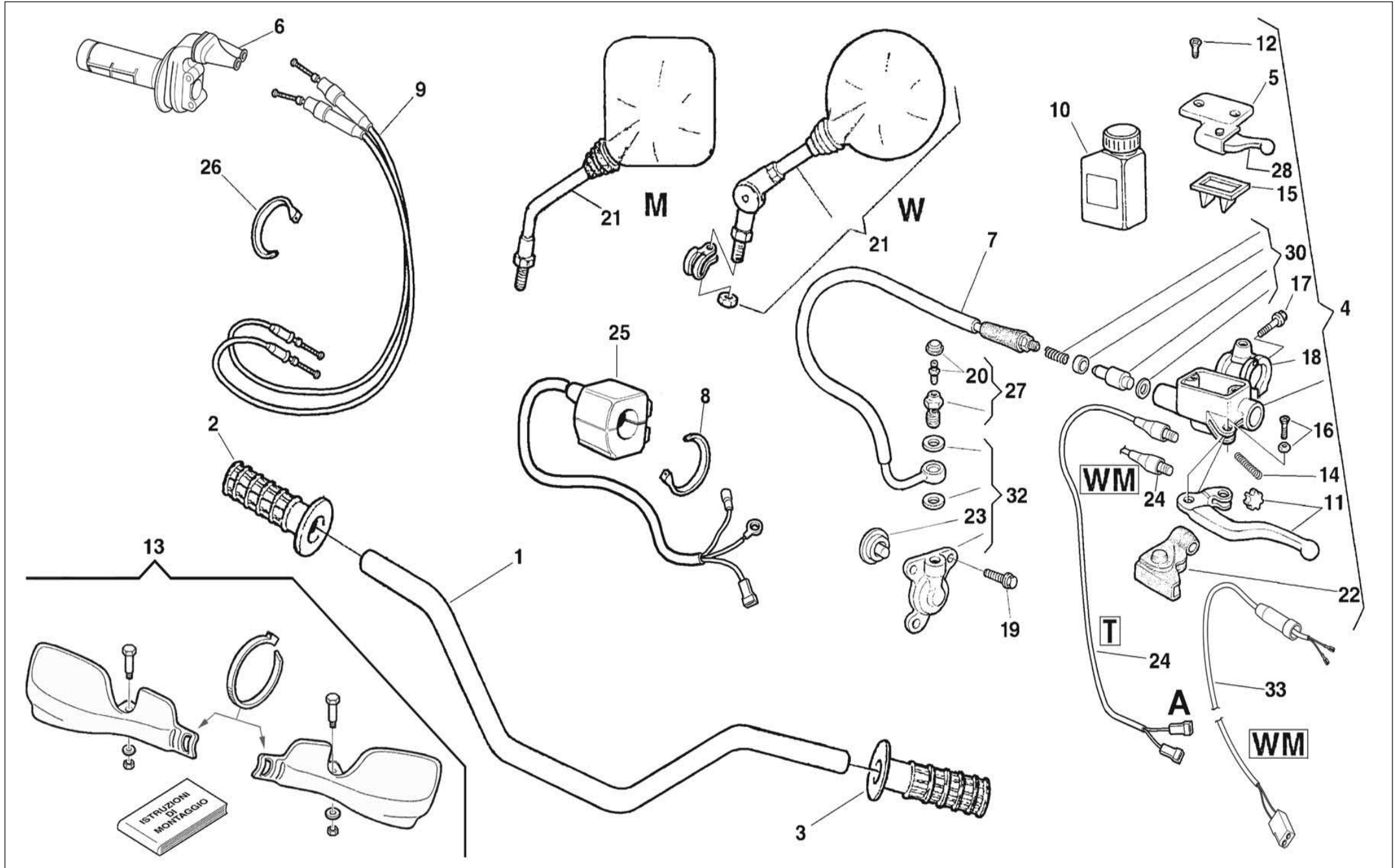



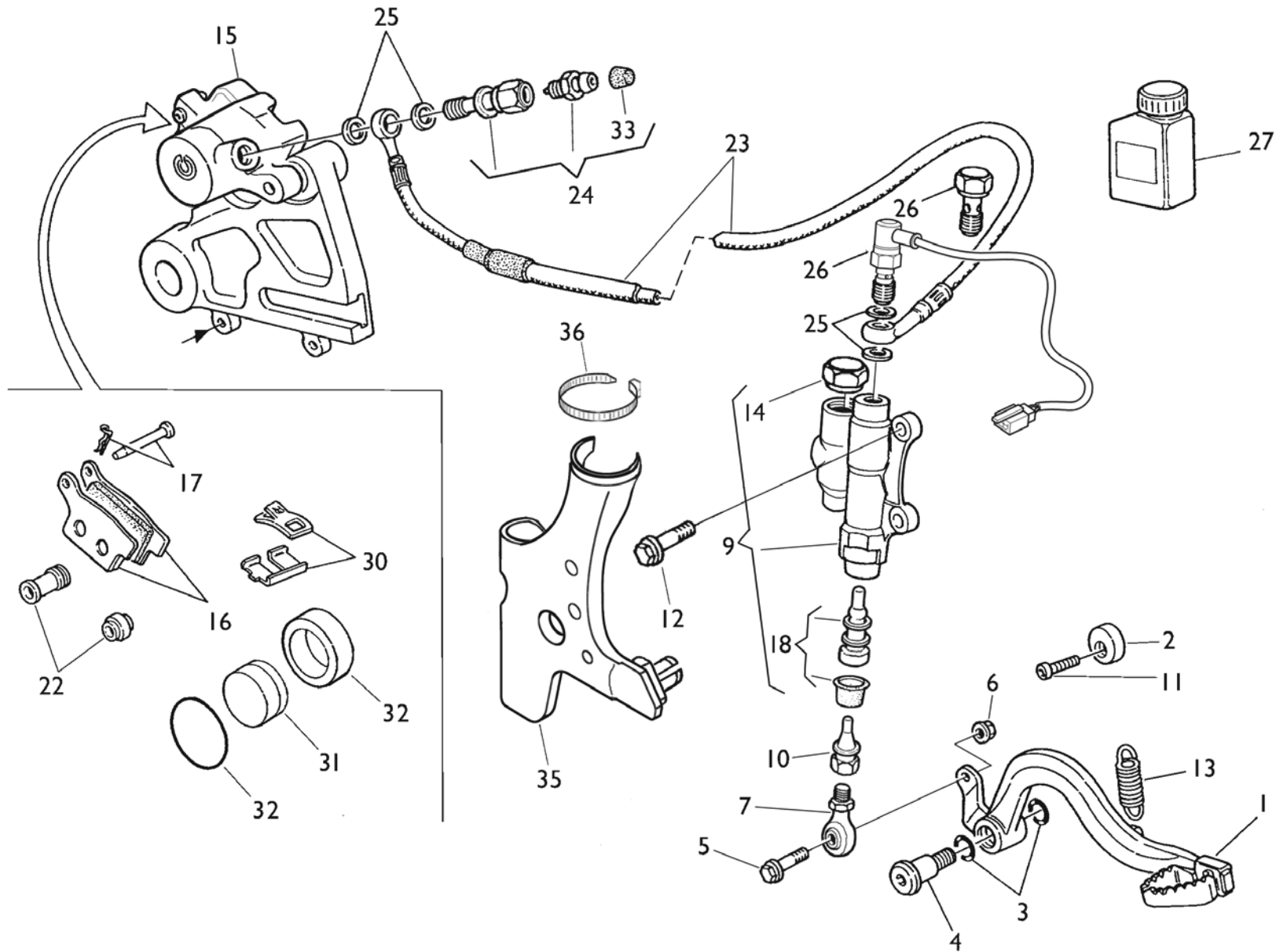



Note Notes Notes Marke Notas	Pos. No. N. Index Pos.	N. Cod. Code No. Nr. Code Code Nr N. Cod.	Q.tà Q.ty Q.te M.ge C.ad	DENOMINAZIONE	NAME	DESIGNATION	BESHREIBUNG	DENOMINACION
	1	8000A7634	1	PEDALE FRENO	PEDAL, BRAKE	PEDALE FREIN	FUSSBREMSPEDAL	PEDAL FRENO
	2	8A0069125	1	ECCENTRICO PEDALE FRENO	ECCENTRIC, ADJUSTMENT BRAKE PEDAL	EXCENTRIQUE REGLAGE PEDAL FREIN	REGULIEREXZENTIKER BREMSE PEDAL	EXCENTRICO REGULACION PEDAL FRENO
	3	800022551	2	ANELLO O-RING 2056 14X1,78	O-RING 2056 14X1.78	JOINT TORIQUE 2056 14X1,78	O-RING 2056 14X1,78	JUNTA TORICA 2056 14X1,78
	4	800055902	1	VITE TPEI M10X1,25X16	SCREW TPEI M10X1.25X16	VIS TPEI M10X1,25X16	SCHRAUBE TPEI M10X1,25X16	TORNILLO TPEI M10X1,25X16
	5	800062727	1	VITE TE M6X1X16 CH8	SCREW TE M6X1X16 CH8	VIS TE M6X1X16 CH8	SCHRAUBE TE M6X1X16 CH8	TORNILLO TE M6X1X16 CH8
	6	61N115062	1	DADO M6X1H4 CH10	NUT M6X1H4 CH10	ECROU M6X1H4 CH10	MUTTER M6X1H4 CH10	TUERCA M6X1H4 CH10
	7	764010002	1	SNODO SFERICO DESTRO	BALL JOINT, RH	JOINT A ROTULE, DROIT	KUGELGELENK, RECHTS	ROTULA ESFERICA DERECHA
ALTERNATIVE	7	8A0076055	1	SNODO SFERICO DESTRO	BALL JOINT, RH	JOINT A ROTULE, DROIT	KUGELGELENK, RECHTS	ROTULA ESFERICA DERECHA
	9	8000A7633	1	POMPA FRENO POSTERIORE	CYLINDER, REAR MASTER	MAITRE CYLINDRE FREIN ARRIERE	HAUPTZYLINDER, HINTEN	BOMBA FRENO TRASERO
	10	8000A7635	1	PUNTALINO POMPA FRENO POSTERIORE	ROD-PUSH, MASTER CYLINDER	BARRE PRESSION	DRUCKSTANGE	VARILLA PRESION
	11	800055241	1	VITE TSEI M6X1X14 CH5	SCREW TSEI M6X1X14 CH5	VIS TSEI M6X1X14 CH5	SCHRAUBE TSEI M6X1X14 CH5	TORNILLO TSEI M6X1X14 CH5
	12	800062726	2	VITE TEF M6X1,00X14 CH8	SCREW TEF M6X1.00X14 CH8	VIS TEF M6X1,00X14 CH8	SCHRAUBE TEF M6X1,00X14 CH8	TORNILLO TEF M6X1,00X14 CH8
	13	800055903	1	MOLLA PEDALE FRENO	SPRING, BRAKE PEDAL	RESSORT PEDALE FREIN	FEDER, BREMSPEDAL	MUELLE PEDAL FRENO
	14	8000A9447	1	TAPPO POMPA FRENO POSTERIORE	PLUG CYLINDER, REAR MASTER	BOUCHON MAITRE CYLINDRE FREIN ARRIERE	VERSCHLUSS HAUPTZYLINDER, HINTEN	TAPON BOMBA FRENO TRASERO
	15	8000A4291	1	PINZA FRENO POSTERIORE	CALIPER, REAR BRAKE	ETRIER FREIN ARRIERE	HINTEN BREMSSEL	PINZA FRENO TRASERA
	16	8000A2790	1	COPIA PASTIGLIE FRENO POSTERIORE	PADS SET, REAR BRAKE	JEU PLAQUETTES FREIN ARRIERE	HINTERBREMSBELAEGESATZ	JUEGO PASTILLAS FRENO TRASERO
	17	8000A2791	1	GRUPPO REVISIONE PERNI PASTIGLIE	PAD PINS OVERHAUL SET	GROUPE REVISION PIVOTS PLAQUETTE	BREMSBELAEGEN EBERHOLUNGSGRUPPE	GRUPO REVISION PERNO PASTILLAS FRENO
	18	8000A9448	1	ASTINA POMPA FRENO	ROD, BRAKE CYLINDER	TIGE MAITRE CYLINDRE	HAUPTZYLINDERSTANGE	VARILLA BOMBA FRENO
	22	800079066	1	SERIE SILENTBLOCK PINZA FRENO	CAPS OVERHAUL SET	GROUPE REVISION CAPOUCHONS	GUMMIUBERARBEITUNGSATZ	GRUPO REVISION GORRO
SMR	23	8000B1162	1	TUBO FRENO POSTERIORE	HOSE, REAR BRAKE	TUYAU FREIN ARRIERE	BREMSSCHLAUCH HINTEN	MANGUERA FRENO TRASERO
TE-TC-TXC	23	8A00B1162	1	TUBO FRENO POSTERIORE	HOSE, REAR BRAKE	TUYAU FREIN ARRIERE	BREMSSCHLAUCH HINTEN	MANGUERA FRENO TRASERO
	24	8000A3975	1	VITE RACCORDO TUBO OLIO	BOLT, OIL PIPE	VIS FIXATION TUYAU HUILE	FIXIERSCHRAUBE OELSCHLAUCH	TORNILLO FIJACION TUBO ACEITE
	25	800021480	4	RONDELLA 14X10,2X1 MM	WASHER 14X10.2X1 MM	RONDELLE 14X10,2X1 MM	SCHEIBE 14X10,2X1 MM	ARANDELA 14X10,2X1 MM
TC-TXC	26	800057155	1	VITE RACCORDO TUBO M10X1,00X19	BOLT, BRAKE HOSE M10X1.00X19	VIS FIXATION TUYAU M10X1,00X19	FIXIERSCHRAUBE M10X1,00X19	TORNILLO FIJACION MANGUERA M10X1,00X19
TE-SMR	26	800094849	1	INTERRUTTORE STOP POSTERIORE	SWITCH, REAR BRAKE	INTERRUPTEUR STOP ARRIERE	HINTEN STOPSCHALTER	INTERRUPTOR STOP TRASERO
	27	800071445	1	LIQUIDO FRENI	BRAKE FLUID	LIQUIDE FREIN	BREMSSFLUESSIGKEIT	LIQUIDO FRENO
	30	8000A2792	1	MOLLETTE PASTIGLIE FRENO	SUPPORT, PAD	RESSORT PLAQUETTE FREIN	FEDER, BREMSSEL	MUELLE PASTILLAS
	31	8000A2793	1	PISTONCINO PINZA FRENO	PISTON, CALIPER	PISTON ETRIER FREIN	KOLBEN BREMSSEL	PISTON PINZA FRENO
	32	8000A2794	1	SERIE GUARNIZIONI PISTONCINO PINZA	KIT GASKET PISTON	KIT GARNITURE PISTON	KIT KOLBENDICHTUNG	KIT JUNTAS PISTON
	33	800053259	1	CAPPUCCIO VITE SPURGO	CAP, BLEEDER SCREW	CAPUCHON VIS RENIFLARD	ENTLUEFTUNGSKAPPE	CAPUCHON TORNILLO PURGA PINZA
	35	80A0B0246	1	PROTEZIONE TELAIO DESTRA	GUARD, FRAME RH	PROTECTION CADRE DROIT	RAHMENSCHUTZ RECHTS	PROTECCION BASTIDOR DERECHA
	36	800056444	1	FASCETTA 188 MM	CLAMP 188 MM	COLLIER 188 MM	SHELLE 188 MM	ABRAZADERA 188 MM

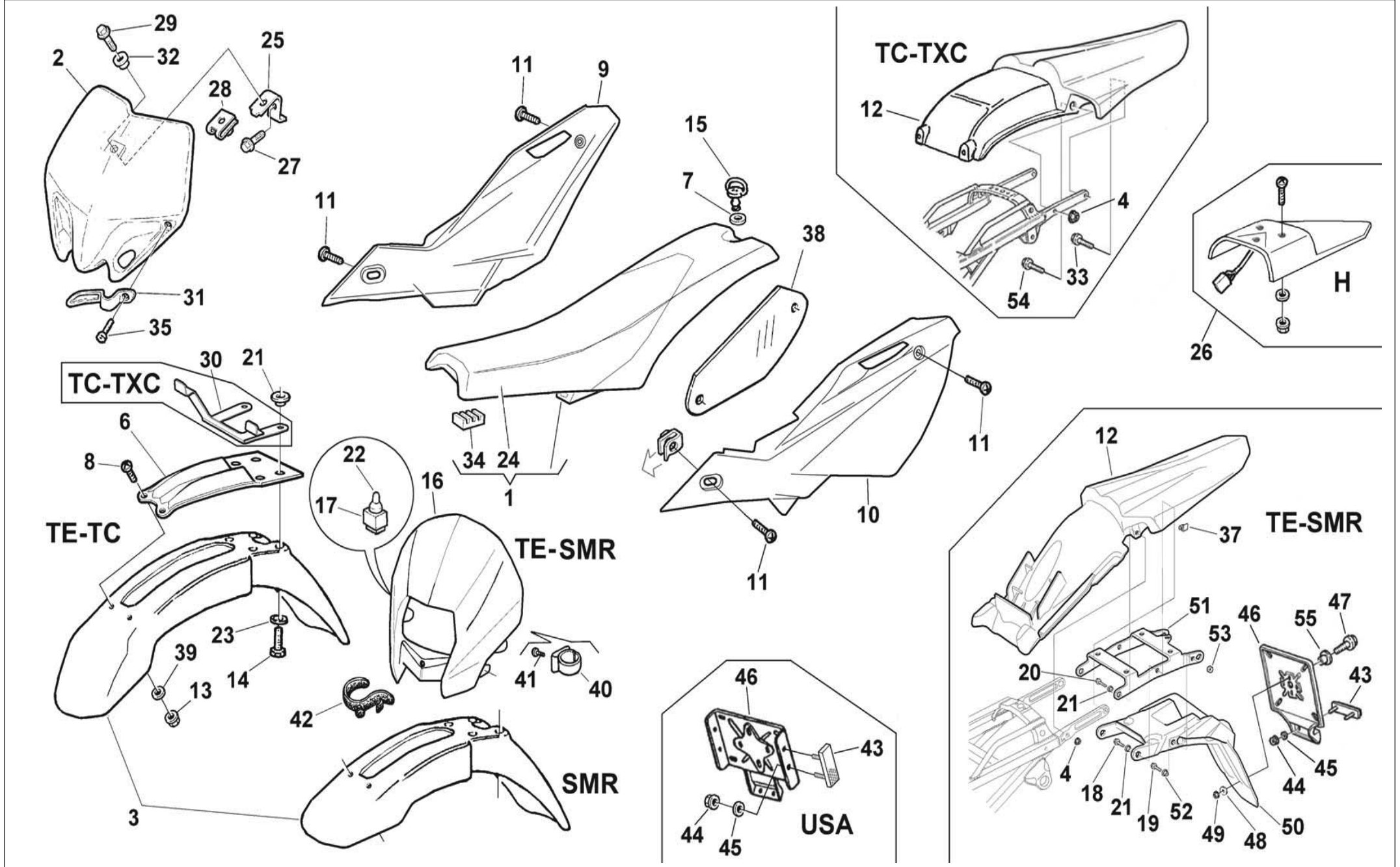

Note Notes Marka Marka Notas	Pos. No. N. Index Pos.	N. Cod. Code No. Nr. Code Code Nr N. Cod.	Q.tà Q.ty Q.te M.ge C.ad	DENOMINAZIONE	NAME	DESIGNATION	BESHREIBUNG	DENOMINACION
BLACK	1	8000B0170	1	SELLA	SEAT	SELLE	SITZBANK	ASIENTO
BLACK TC-TXC	2	80A0A4216	1	TABELLA PORTANUMERO ANTERIORE	PLATE, NUMBER	TABLIER PORTE NUMERO	VORNE NUMMERTAFEL	PORTA NUMERO DELANTERO
WHITE SMR	3	80B0B0344	1	PARAFANGO ANTERIORE	FRONT FENDER	GARDE BOUE AVANT	VORDERER KOTFLUGEL	GUARDABARROS DELANTERO
BIANCO TE-TC-TXC	3	80B0B0159	1	PARAFANGO ANTERIORE	FRONT FENDER	GARDE BOUE AVANT	VORDERER KOTFLUGEL	GUARDABARROS DELANTERO
	4	800061313	2	DADO M6X1 H6 CH10	NUT M6X1 H6 CH10	ECROU M6X1 H6 CH10	MUTTER M6X1 H6 CH10	TUERCA M6X1 H6 CH10
	6	80A0A4198	1	SUPPORTO PARAFANGO ANTERIORE	FRONT FENDER BRACKET	EQUERRE GARDE-BOUE AVANT	KONSOLE VORNE KOTFLUEGEL	SOPORTE GUARDABARROS DELANTERO
	7	800069149	1	RONDELLA 17X9X1	WASHER 17X9X1	RONDELLE 17X9X1	SCHEIBE 17X9X1	ARANDELA 17X9X1
	8	80A065535	2	VITE TCEI M5X0,8X14	SCREW TCEI M5X0,8X14	VIS TCEI M5X0,8X14	SCHRAUBE TCEI M5X0,8X14	TORNILLO TCEI M5X0,8X14
	9	80B0B0164	1	FIANCHETTO DESTRO	COVER FRAME RH	PANNEAU DROIT	SEITENDECKEL, RECHTS	CUBIERTA LATERAL DERECHA
	10	80B0B0163	1	FIANCHETTO SINISTRO	COVER FRAME LH	PANNEAU GAUCHE	SEITENDECKEL, LINKS	CUBIERTA LATERAL IZQUERDA
	11	8B00A8421	4	VITE FLANGIATA M5X16	SCREW M5X16	VIS M5X16	SCHRAUBE M5X16	TORNILLO M5X16
WHITE	12	80B0B0162	1	PARAFANGO POSTERIORE	FENDER, REAR	GARDE-BOUE ARRIERE	KOTFLUEGEL HINTEN	GUARDABARROS TRASERO
	13	800061355	2	DADO M5X0,8 CH8	NUT M5X0,8 CH8	ECROU M5X0,8 CH8	MUTTER M5X0,8 CH8	TUERCA M5X0,8 CH8
TC-TXC	14	800062729	4	VITE TEF M6X1X25 CH8	SCREW TEF M6X1X25 CH8	VIS TEF M6X1X25 CH8	SCHRAUBE TEF M6X1X25 CH8	TORNILLO TEF M6X1X25 CH8
TE-SMR	14	800062728	4	VITE TEF M6X1X20 CH8	SCREW TEF M6X1X20 CH8	VIS TEF M6X1X20 CH8	SCHRAUBE TEF M6X1X20 CH8	TORNILLO TEF M6X1X20 CH8
	15	800069148	1	PERNO ATTACCO SELLA	PIN, SADDLE	AXE SELLE	SITZACHSE	PERNO ASIENTO
BLACK TE-SMR	16	80A0A4206	1	CUPOLINO	COWLING	CAPOT	KOPFVERKLEIDUNG	CUPULA
RACING, NO USA	17	800093221	1	COMMUTATORE LUCI	SWITCH, LIGHTS	COMMUTATEUR FEUX	LICHTSCHALTER	CONMUTADOR LUCES
	18	800062728	2	VITE TEF M6X1X20 CH8	SCREW TEF M6X1X20 CH8	VIS TEF M6X1X20 CH8	SCHRAUBE TEF M6X1X20 CH8	TORNILLO TEF M6X1X20 CH8
	19	800062727	2	VITE TE M6X1X16 CH8	SCREW TE M6X1X16 CH8	VIS TE M6X1X16 CH8	SCHRAUBE TE M6X1X16 CH8	TORNILLO TE M6X1X16 CH8
	20	800062729	2	VITE TEF M6X1X25 CH8	SCREW TEF M6X1X25 CH8	VIS TEF M6X1X25 CH8	SCHRAUBE TEF M6X1X25 CH8	TORNILLO TEF M6X1X25 CH8
	21	8C0069429	8	BOCCOLA	BUSH	DOUILLE	BUCHSE	BUJE
RACING, NO USA	22	800071755	1	CAPPUCCIO	BOOT	CAPUCHON	KAPPE	CAPUCHON
	23	800048814	4	RONDELLA 18X6,4X2	WASHER 18X6,4X2	RONDELLE 18X6,4X2	SCHEIBE 18X6,4X2	ARANDELA 18X6,4X2
BLACK	24	8000B0171	1	COPERTINA SELLA	COVER, SEAT	HOUSSE SELLE	SITZBANKUEBERZUG	CUBIERTA ASIENTO
TC-TXC	25	8000A4609	1	PIASTRINA	PLATE	PLAQUETTE	PLAETTCHEN	PLETINA
	26	8000B1641	1	PIASTRA PORTATARGA	BRACKET, LICENSE PLATE	PORTE-PLAQUE IMMATRICULATION	KONSOLE, KENNZEICHEN	PORTA-MATRICULA
TC-TXC	27	8E0067997	1	VITE TEF M5X0,8X10	SCREW TEF M5X0,8X10	VIS TEF M5X0,8X10	SCHRAUBE TEF M5X0,8X10	TORNILLO TEF M5X0,8X10
TC-TXC	28	800046893	1	DADO ELASTICO M6X1	CLIP NUT M6X1	JONC M6X1	KLEMME M6X1	PREASIENTO M6X1
TC-TXC	29	800062726	1	VITE TEF M6X1,00X14 CH8	SCREW TEF M6X1,00X14 CH8	VIS TEF M6X1,00X14 CH8	SCHRAUBE TEF M6X1,00X14 CH8	TORNILLO TEF M6X1,00X14 CH8
TC-TXC	30	8000A6644	1	SUPPORTO CUPOLINO	BRACKET, COWLING	SUPPORT CAPOT	KONSOLE, KOPFVERKLEIDUNG	SOPORTE CUPULA
TC-TXC	31	80A0A4610	1	GUIDA TUBO FRENO	CLAMP, BRAKE HOSE	GUIDE TUYAU FREIN	FUEHRUNG, BREMSSCHLAUCH	GUIA MANGUERA FRENO

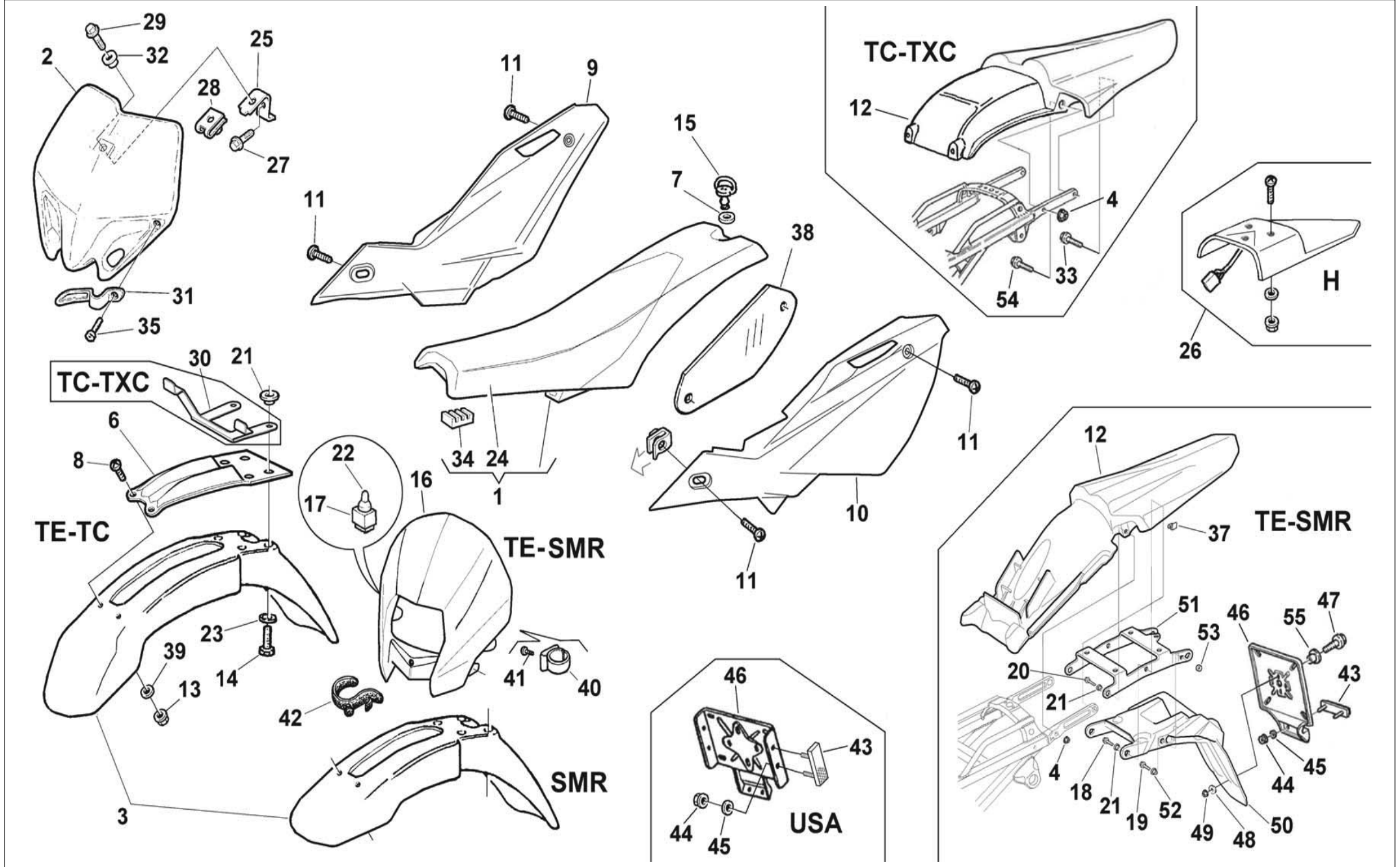

Note Notes Notes Marke Notas	Pos. No. N. Index Pos.	N. Cod. Code No. Nr. Code Code Nr N. Cod.	Q.tà Q.ty Q.te M.ge C.ad	DENOMINAZIONE	NAME	DESIGNATION	BESHREIBUNG	DENOMINACION
	32	800069429	1	BOCCOLA 9X7X4,8	BUSH 9X7X4.8	DOUILLE 9X7X4,8	BUCHSE 9X7X4,8	BUJE 9X7X4,8
TC-TXC	33	8000A8423	2	VITE FLANGIATA M6X8	BOLT, FLANGE M6X8	VIS A EMBASE M6X8	GEFLANSCHSCHRAUBE M6X8	TORNILLO CON VALONA M6X8
	34	86610191A	2	TAMPONE IN GOMMA	CUSHION RUBBER	TAMPON EN CAOUTCHOUC	GUMMISTOPFEN	TAMPON GOMA
TC-TXC	35	800062728	1	VITE TEF M6X1X20 CH8	SCREW TEF M6X1X20 CH8	VIS TEF M6X1X20 CH8	SCHRAUBE TEF M6X1X20 CH8	TORNILLO TEF M6X1X20 CH8
TE-SMR	37	800072494	1	MOLLETTA FERMA CAVO	CLAMP, WIRE	COLLIER, CORDON	KABELBINDER	GRAMPA CORDON
	38	8000B0167	1	ISOLANTE TERMICO	GUARD, HEAT	ISOLATEUR THERMIQUE	WAERMISOLIERSTOFF	AISILANTE ATERMICO
	39	62N115548	2	RONDELLA 15X5,3X1	WASHER 15X5.3X1	RONDELLE 15X5,3X1	SCHEIBE 15X5,3X1	ARANDELA 15X5,3X1
TE-SMR	40	8000A0864	1	GUIDA TUBO FRENO ANTERIORE	GUIDE, FRONT BRAKE HOSE	GUIDE TUYAU FREIN AVANT	BREMSSCHLAUCH VORNEFUEHRUNG	GUIA MANGUERA FRENO DELANTERO
TE-SMR	41	8A0037283	2	VITE AUTOFILETTANTE AB 3,5X9,5	SCREW SELF-TAPPING AB 3.5X9.5	VIS TARAUD AB 3,5X9,5	GEWINDESCHRAUBE AB 3,5X9,5	TORNILLO AUTOROSCANTE AB 3,5X9,5
TE-SMR	42	800088602	4	ELASTICO FISSAGGIO PORTAFARO	RUBBER	ELASTIQUE	GUMMISCHNUR	ELASTICO
TE-SMR	43	800073834	1	CATADIOTTRO POSTERIORE	REFLEX REFLECTOR, REAR	CATADIOPTRE ARRIERE	RUECKSTRAHLER	CATAFARO TRASERO
USA	43	800073834	2	CATADIOTTRO POSTERIORE	REFLEX REFLECTOR, REAR	CATADIOPTRE ARRIERE	RUECKSTRAHLER	CATAFARO TRASERO
TE-SMR	44	800040717	2	DADO FLANGIATO M4X0,7	NUT FLANGE M4X0.7	ECROU BRIDE M4X0,7	GEFLANSCHTE MUTTER M4X0,7	TUERCA CON REBORDE M4X0,7
TE-SMR	45	62N115547	2	RONDELLA 12X4,3X0,8	WASHER 12X4.3X0.8	RONDELLE 12X4,3X0,8	SCHEIBE 12X4,3X0,8	ARANDELA 12X4,3X0,8
TE-SMR	46	800094595	1	PIASTRA PORTATARGA	BRACKET, LICENSE PLATE	PORTE-PLAQUE IMMATRICULATION	KONSOLE, KENNZEICHEN	PORTA-MATRICULA
TE-SMR USA	46	800094038	1	PIASTRA PORTATARGA	BRACKET, LICENSE PLATE	PORTE-PLAQUE IMMATRICULATION	KONSOLE, KENNZEICHEN	PORTA-MATRICULA
TE-SMR	47	8A0067997	2	VITE TEF M5X0,8X16	SCREW TEF M5X0.8X16	VIS TEF M5X0,8X16	SCHRAUBE TEF M5X0,8X16	TORNILLO TEF M5X0,8X16
TE-SMR	48	62N115548	2	RONDELLA 15X5,3X1	WASHER 15X5.3X1	RONDELLE 15X5,3X1	SCHEIBE 15X5,3X1	ARANDELA 15X5,3X1
TE-SMR	49	800056443	2	DADO AUTOBLOCCANTE M5X0,8 CH8	NUT, SELF LOCKING M5X0.8 CH8	ECROU AUTOBLOQUANT M5X0,8 CH8	SELBSTSPERRENDE MUTTER M5X0,8 CH8	TUERCA AUTOBLOQUEANTE M5X0,8 CH8
TE-SMR	50	8000A7860	1	PARAFANGO POSTERIORE PORTATARGA	FENDER, REAR NUMBER PLATE HOLDER	GARDE-BOUE ARRIERE PORTE-PLAQUE	KOTFLUEGEL HINTEN KENNZEICHEN	GUARDABARROS TRASERO PORTA-MATRICULA
	51	8A00A5377	1	SUPPORTO PORTATARGA	BRACKET, NUMBER-PLATE	PORTE-PLAQUE IMMATRICULATION	KONSOLE KENNZEICHEN	PORTAMATRICULA
	52	80A045495	2	BOCCOLA	BUSH	DOUILLE	BUCHSE	BUJE
	53	800044240	2	DADO AUTOBLOCCANTE M6X1 CH10	NUT, SELF LOCKING M6X1 CH10	ECROU AUTOBLOQUANT M6X1 CH10	SELBSTSPERRENDE MUTTER M6X1 CH10	TUERCA AUTOBLOQUEANTE M6X1 CH10
TC-TXC	54	8B00A8423	2	VITE FLANGIATA M6X16	BOLT FLANGE M6X16	VIS A EMBASE M6X16	GEFLANSCHSCHRAUBE M6X16	TORNILLO CON VALONA M6X16
	55	800069282	2	BOCCOLA 14X7X5,25 MM	BUSH 14X7X5.25 MM	DOUILLE 14X7X5,25 MM	BUCHSE 14X7X5,25 MM	CASQUILLO 14X7X5,25 MM

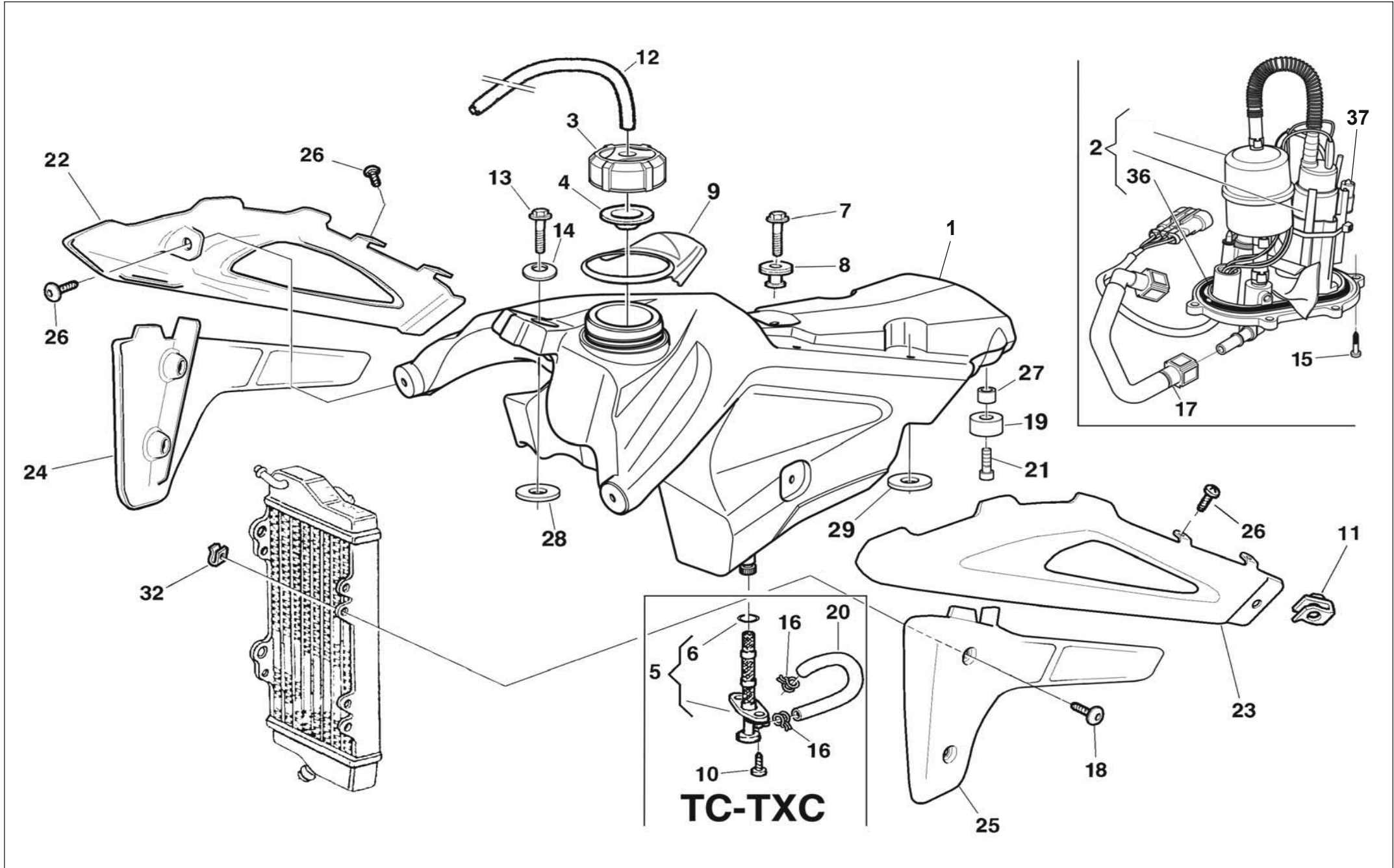

Note Notes Notes Marke Notas	Pos. No. N. Index Pos.	N. Cod. Code No. Nr. Code Code Nr N. Cod.	Q.tà Q.ty Q.te M.ge C.ad	DENOMINAZIONE	NAME	DESIGNATION	BESHREIBUNG	DENOMINACION
TC-TXC	1	80A0B0445	1	SERBATOIO CARBURANTE	FUEL TANK	RESERVOIR CARBURANT	KRAFTSTOFFTANK	DEPOSITO CARBURANTE
TE-SMR	1	80A0B0249	1	SERBATOIO CARBURANTE	FUEL TANK	RESERVOIR CARBURANT	KRAFTSTOFFTANK	DEPOSITO CARBURANTE
TE-SMR	2	8000B0376	1	POMPA CARBURANTE	PUMP, FUEL	POMPE CARBURANT	KRAFTSTOFFPUMPE	BOMBA CARBURANTE
	3	8000B1057	1	TAPPO SERBATOIO CARBURANTE	CAP SET, FUEL TANK	BOUCHON RESERVOIR CARBURANT	VERSCHLUSS, KRAFTSTOFFTANK	TAPON DEPOSITO CARBURANTE
	4	8000A4562	1	GUARNIZIONE TAPPO SERBATOIO	GASKET, CAP	JOINT, BOUCHON RESERVOIR	DICHTUNG, VERSCHLUSSKAPPE	JUNTA TAPON DEPOSITO
TC-TXC	5	800067440	1	RUBINETTO CARBURANTE SINISTRO	FUEL COCK, LH	ROBINET ESSENCE GAUCHE	KRAFTSTOFFHAHN, LINKS	GRIFO GASOLINA IZQUERDO
TC-TXC	6	8000A8278	1	ANELLO O-RING 2X11	O-RING 2X11	JOINT TORIQUE 2X11	O-RING 2X11	JUNTA TORICA 2X11
	7	60N104134	1	VITE TSCI M6X1,00X20	SCREW TSCI M6X1.00X20	VIS TSCI M6X1,00X20	SCHRAUBE TSCI M6X1,00X20	TORNILLO TSCI M6X1,00X20
	8	800066238	1	DISTANZIALE 20X10X6,5X12 MM	SPACER 20X10X6.5X12 MM	ENTRETOISE 20X10X6,5X12 MM	ABSTANDHALTER 20X10X6,5X12 MM	DISTANCIADOR 20X10X6,5X12 MM
	9	8000B1390	1	PROTEZIONE TAPPO	PLUG GUARD	PROTECTION	SCHUTZ	PROTECCION
	10	800037745	2	VITE TCIC AUTOFILETTANTE 5,5X19	SCREW SELF-TAPPING TC1C 5.5X19	VIS TARAUD TC1C 5,5X19	GEWINDESCHRAUBE TC1C 5,5X19	TORNILLO AUTOROSCANTE TC1C 5,5X19
	11	800055134	2	DADO ELASTICO M5X0,8	NUT M5X0.8	ECROU M5X0,8	MUTTER M5X0,8	TUERCA M5X0,8
	12	8T0068873	1	TUBO CARBURANTE 300 MM	HOSE, FUEL 300 MM	TUYAU CARBURANT 300 MM	KRAFTSTOFFSCHLAUCH 300 MM	MANGUERA CARBURANTE 300 MM
	13	60N407335	1	VITE TCEI M6X1,00X16	SCREW TCEI M6X1.00X16	VIS TCEI M6X1,00X16	SCHRAUBE TCEI M6X1,00X16	TORNILLO TCEI M6X1,00X16
	14	8000A5678	1	RONDELLA PIANA	WASHER, PLAIN	RONDELLE, PLATE	UNTERLEGSCHLEIBE	ARANDELA PLANA
TE-SMR	15	8A0067997	6	VITE TEF M5X0,8X16	SCREW TEF M5X0.8X16	VIS TEF M5X0,8X16	SCHRAUBE TEF M5X0,8X16	TORNILLO TEF M5X0,8X16
	16	80A042349	2	FASCETTA	CLAMP	COLLIER	KLAMMER	ABRAZADERA
TE-SMR	17	8000B0250	1	TUBO CARBURANTE ALTA PRESSIONE	HOSE, FUEL HIGH PRESSURE	TUYAU CARBURANT HAUTE PRESSION	KRAFTSTOFFSCHLAUCH HOCHDRUCK	MANGUERA CARBURANTE ALTA PRESION
	18	8A00A8423	4	VITE FLANGIATA M6X12	BOLT, FLANGE M5X12	VIS A EMBASE M5X12	GEFLANSCHSCHRAUBE M5X12	TORNILLO CON VALONA M5X12
	19	8000B0647	2	TAMPONE SERBATOIO	CUSHION, FUEL TANK	TAMPON APPUI RESERVOIR	DAEMPFER TANKAUFLAGE	TAMPON APOYO DEPOSITO
	20	8G0094010	1	TUBO CARBURANTE 170 MM	HOSE FUEL 170 MM	TUYAU CARBURANT 170 MM	KRAFTSTOFFSCHLAUCH 170 MM	TUBO CARBURANTE 170 MM
	21	800037745	2	VITE TCIC AUTOFILETTANTE 5,5X19	SCREW SELF-TAPPING TC1C 5.5X19	VIS TARAUD TC1C 5,5X19	GEWINDESCHRAUBE TC1C 5,5X19	TORNILLO AUTOROSCANTE TC1C 5,5X19
RED	22	80B0B0172	1	CONVOGLIATORE DESTRO	COVER RADIATOR RH	OUIE RADIATEUR DROITE	LEITBLECH RECHTS	PROTECTOR RADIADOR DERECHO
RED	23	80B0B0169	1	CONVOGLIATORE SINISTRO	COVER RADIATOR LH	OUIE RADIATEUR GAUCHE	LEITBLECH LINKS	PROTECTOR RADIADOR IZQUERDO
	24	80A0B0244	1	PROTEZIONE RADIATORE DESTRA	RADIATOR COVER RIGHT	PROTECTION RADIATEUR DROIT	KUEHLERSCHUTZ, RECHTS	PROTECCION RADIADOR DERECHO
	25	80A0B0243	1	PROTEZIONE RADIATORE SINISTRA	COVER RADIATOR LH	PROTECTION RADIATEUR GAUCHE	KUEHLERSCHUTZ, LINKS	PROTECCION RADIADOR IZQUERDO
	26	8000A8421	8	VITE FLANGIATA M5X8	BOLT, FLANGE M5X8	VIS A EMBASE M5X8	FLANSCHENSCHRAUBE M5X8	TORNILLO CON VALONA M5X8
	27	8B00A0680	2	DISTANZIALE 10,5X6,5X5 MM	SPACER 10.5X6.5X5 MM	ENTRETOISE 10,5X6,5X5 MM	ABSTANDHALTER 10,5X6,5X5 MM	DISTANCIADOR 10,5X6,5X5 MM

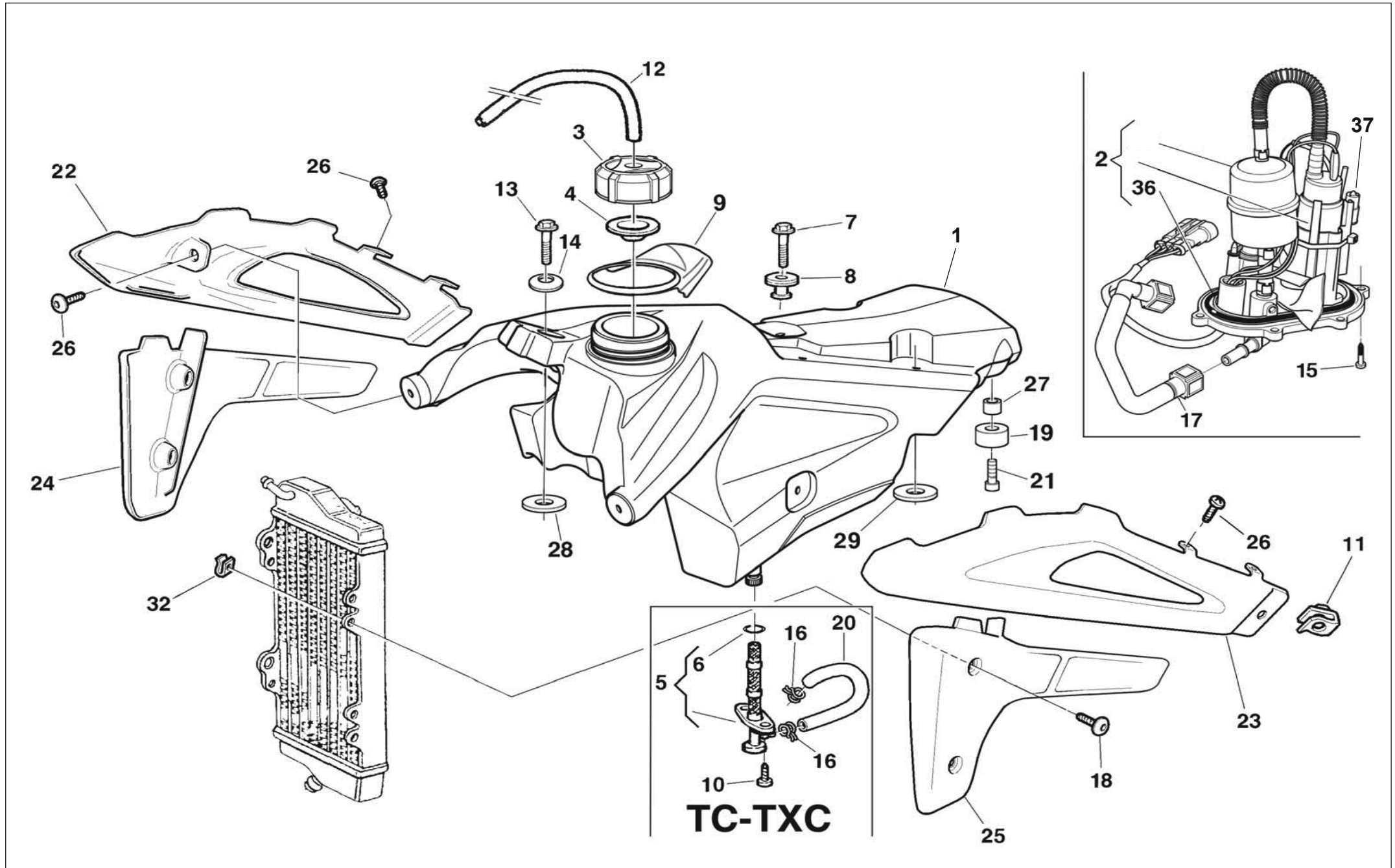





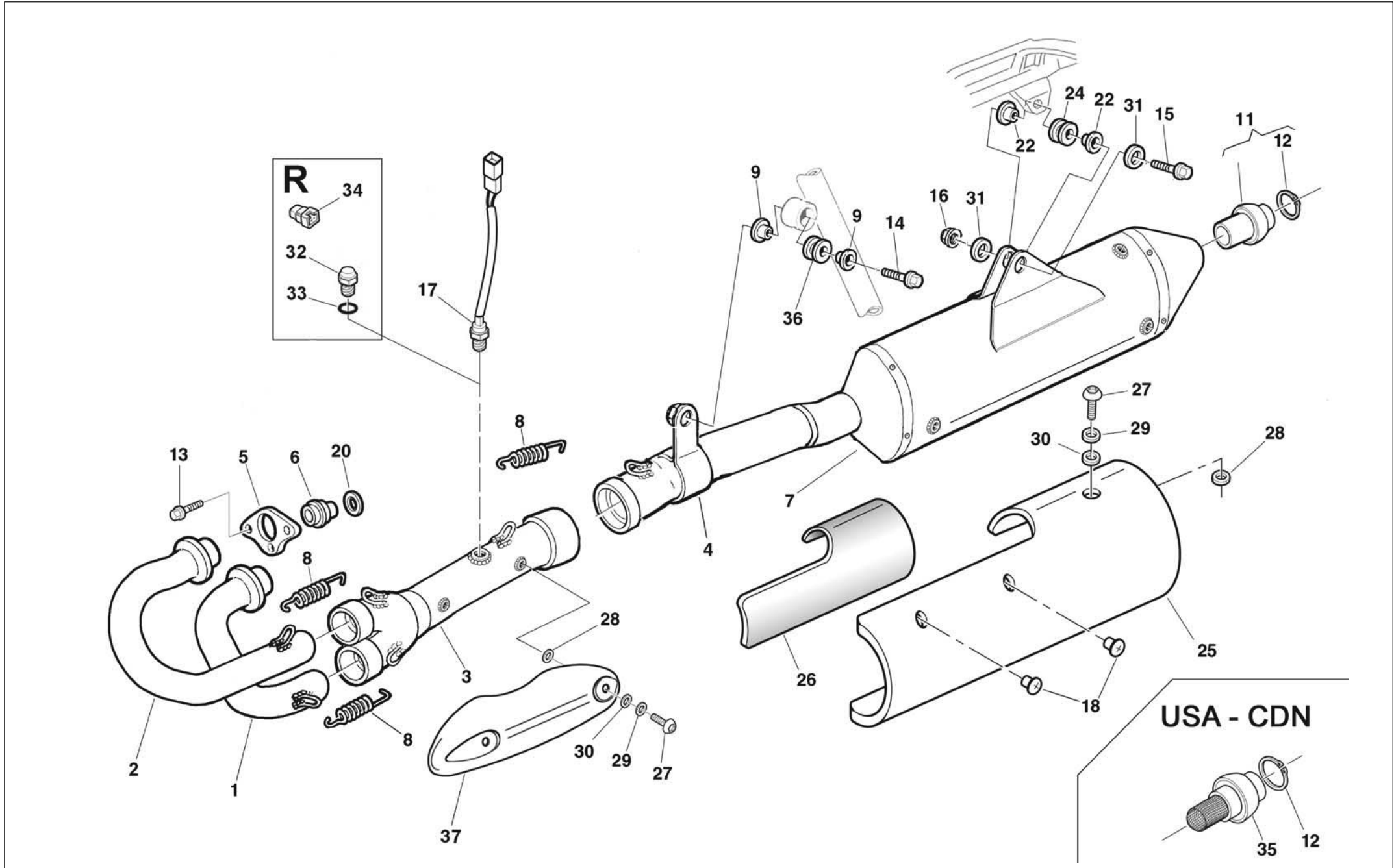

Note Notes Notas	Pos. No. N. Index Pos.	N. Cod. Code No. Nr. Code Code Nr N. Cod.	Q.tà Q.ty Q.te M.ge C.ad	DENOMINAZIONE	NAME	DESIGNATION	BESHREIBUNG	DENOMINACION
	1	8000B0450	1	COLLETTORE SCARICO DESTRO	PIPE EXHAUST RH	TUYAU ECHAPPEMENT DROIT	AUSPUFFKRUEMMER, RECHTS	TUBERIA ESCAPE DERECHO
	1	8000B0260	1	COLLETTORE SCARICO DESTRO	PIPE, EXHAUST RH	TUYAU ECHAPPEMENT DROIT	RECHTES AUSPUFFROHR	TUBERIA ESCAPE DERECHO
	2	8000B0449	1	COLLETTORE SCARICO SINISTRO	PIPE, EXHAUST LH	TUYAU ECHAPPEMENT GAUCHE	AUSPUFFROHR, LINKS	TUBERIA ESCAPE IZQUERDO
	2	8000B0259	1	COLLETTORE SCARICO SINISTRO	PIPE EXHAUST LH	TUYAU ECHAPPEMENT GAUCHE	LINKS AUSPUFFKRUEMMER	TUBERIA ESCAPE IZQUERDO
TC 450-510-TXC 450-510	3	8000B0464	1	COLLETTORE SCARICO	MANIFOLD, EXHAUST	COLLECTEUR D'ECHAPPEMENT	AUSPUFFKRUEMMER	COLECTOR DE ESCAPE
TC-TXC 250	3	8000B0451	1	COLLETTORE SCARICO	MANIFOLD, EXHAUST	COLLECTEUR D'ECHAPPEMENT	AUSPUFFKRUEMMER	COLECTOR DE ESCAPE
TE 250	3	8000B0261	1	COLLETTORE SCARICO	MANIFOLD, EXHAUST	COLLECTEUR D'ECHAPPEMENT	AUSPUFFKRUEMMER	COLECTOR DE ESCAPE
TE 450-510, SMR	3	8000B0278	1	COLLETTORE SCARICO	MANIFOLD, EXHAUST	COLLECTEUR D'ECHAPPEMENT	AUSPUFFKRUEMMER	COLECTOR DE ESCAPE
	5	8000A0870	2	FLANGIA SCARICO	HOLDER-EXHAUST PIPE	BRIDE ECHAPPEMENT	FLANSCH AUSPUFFROHR	BRIDA TUBERIA ESCAPE
250	6	8000A0871	2	BOCCOLA	BUSH	DOUILLE	BUCHSE	BUJE
450-510	6	8000A0893	2	BOCCOLA	BUSH	DOUILLE	BUCHSE	BUJE
TC-TXC	7	8000B0452	1	SILENZIATORE IN TITANIO	SILENCER, TITANIUM	SILENCIEUX TITANE	SCHALLDAEMPFER AUS TITAN	SILENCIADOR TITANIO
TE-SMR	7	8000B0518	1	SILENZIATORE	SILENCER MUFFLER	SILENCIEUX	SCHALLDAEMPFER	SILENCIADOR
TXC-TE-SMR	7	8000B0145	1	SILENZIATORE LIBERO	SILENCER FULL POWER	SILENCIEUX PLEIN PUISSANCE	SCHALLDAEMPFER HOCHLESTUNG	SILENCIADOR POTENCIA PIENA
	8	8000A1239	5	MOLLA SCARICO	SPRING, EXHAUST PIPE	RESSORT ANCRAGE TUYAU ECHAPPEMENT	FEDER AUSPUFFROHRBEFESTIGUNG	MUELLE ANCLAJE TUBERIA ESCAPE
	9	8000B0263	2	DISTANZIALE	SPACER	ENTRETOISE	ABSTANDHALTER	DISTANCIADOR
TC-TXC	11	8000B1546	1	LIMITATORE EMISSIONI SONORE	NOISE REDUCTION DEVICE	REDUCTEUR BRUIT	DAEMPFPAKET	REDUCTOR RUIDO
TC-TXC	12	8000B1305	1	ANELLO ELASTICO	SPRING RING	ANNEAU ARRET	SPRENGRING	ANILLO RETENCION
	13	800062726	4	VITE TEF M6X1,00X14 CH8	SCREW TEF M6X1.00X14 CH8	VIS TEF M6X1,00X14 CH8	SCHRAUBE TEF M6X1,00X14 CH8	TORNILLO TEF M6X1,00X14 CH8
	14	8A0067545	1	VITE TEF M6X1,00X35 CH8	SCREW TEF M6X1.00X35 CH8	VIS TEF M6X1,00X35 CH8	SCHRAUBE TEF M6X1,00X35 CH8	TORNILLO TEF M6X1,00X35 CH8
TC-TXC	15	8A0067545	1	VITE TEF M6X1,00X35 CH8	SCREW TEF M6X1.00X35 CH8	VIS TEF M6X1,00X35 CH8	SCHRAUBE TEF M6X1,00X35 CH8	TORNILLO TEF M6X1,00X35 CH8
TE-SMR	15	8E0067545	1	VITE TEF M6X1,00X40 CH8	SCREW TEF M6X1.00X40 CH8	VIS TEF M6X1,00X40 CH8	SCHRAUBE TEF M6X1,00X40 CH8	TORNILLO TEF M6X1,00X40 CH8
	16	800044240	1	DADO AUTOBLOCCANTE M6X1 CH10	NUT, SELF LOCKING M6X1 CH10	ECROU AUTOBLOQUANT M6X1 CH10	SELBSTSPERRENDE MUTTER M6X1 CH10	TUERCA AUTOBLOQUEANTE M6X1 CH10
	17	8000A6741	1	SENSORE OSSIGENO	SENSOR, OXYGEN	CAPTEUR OXYGENE	ABTASTER SAUERSTOFF	SENSOR OXYGENO
	18	800048802	2	GOMMINO	GROMMET	CAOUTCHOUC	GUMMITEILE	GOMA
250	20	8000A0873	2	GUARNIZIONE SCARICO	GASKET, EXHAUST PIPE	JOINT TUYAU ECHAPPEMENT	DICHTUNG, AUSPUFFROHR	JUNTA TUBERIA ESCAPE
450-510	20	8A00A0873	2	GUARNIZIONE SCARICO	GASKET, EXHAUST PIPE	JOINT TUYAU ECHAPPEMENT	DICHTUNG, AUSPUFFROHR	JUNTA TUBERIA ESCAPE
	22	8000A7729	2	DISTANZIALE	SPACER	ENTRETOISE	ABSTANDHALTER	DISTANCIADOR
	24	800089302	1	SILENTBLOCK	DAMPER	SILENTBLOC	SCHWINGUNGSDAEMPFER	CASQUILLO ELASTICO
TE-SMR	25	8A00A7721	1	PROTEZIONE SILENZIATORE	PROTECTOR MUFFLER	PROTECTION SILENCIEUX	SCHALLDAEMPFERSCHUTZ	PROTECCION SILENCIADOR
TE-SMR	26	8A00A8498	1	ISOLANTE TERMICO	SHIELD, HEAT	ISOLATEUR THERMIQUE	WAERMISOLIERSTOFF	AISLANTE ATERMICO
TE-SMR	27	800055699	6	VITE TCEI M6X1X10	SCREW TCEI M6X1X10	VIS TCEI M6X1X10	SCHRAUBE TCEI M6X1X10	TORNILLO TCEI M6X1X10
TE-SMR	28	800035112	6	RONDELLA ISOLANTE 14X5,5X2 MM	INSULATING WASHER 14X5.5X2 MM	RONDELLE ISOLANTE 14X5,5X2 MM	ISOLIERSCHEIBE 14X5,5X2 MM	ARANDELA AISLANTE 14X5,5X2 MM

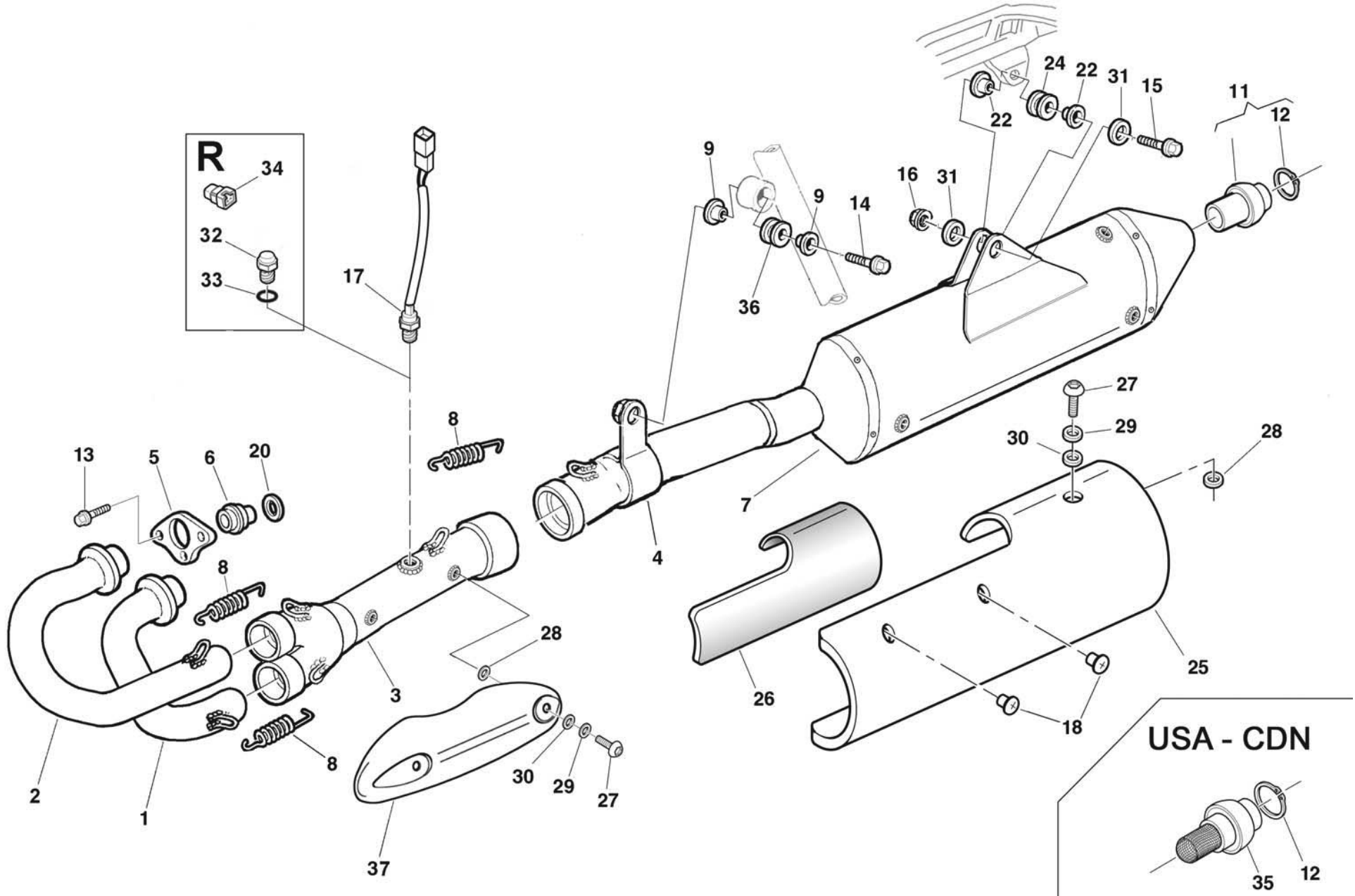



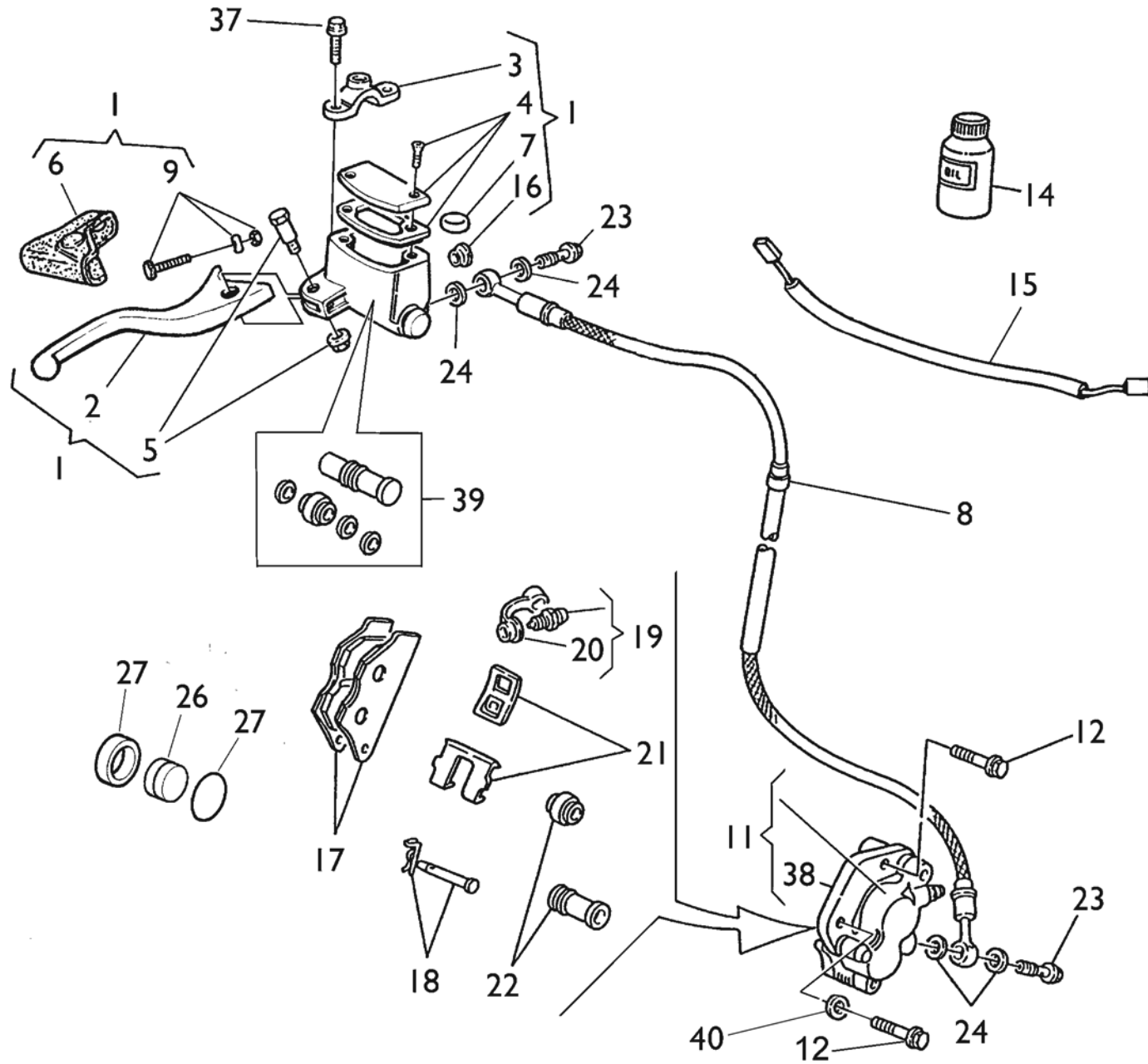

Note Notes Marke Notas	Pos. No. N. Index Pos.	N. Cod. Code No. Nr. Code Code Nr N. Cod.	Q.tà Q.ty Q.te M.ge C.ad	DENOMINAZIONE	NAME	DESIGNATION	BESHREIBUNG	DENOMINACION
TC-TXC	1	8000A9347	1	POMPA FRENO ANTERIORE	CYLINDER, FRONT MASTER	MAITRE CYLINDRE FREIN AVANT	HAUPTZYLINDER, VORNE	BOMBA FRENO DELANTERO
TE	1	8000A9348	1	POMPA FRENO ANTERIORE	CYLINDER, FRONT MASTER	MAITRE CYLINDRE FREIN AVANT	HAUPTZYLINDER, VORNE	BOMBA FRENO DELANTERO
TC-TXC	2	8000A9351	1	LEVA FRENO ANTERIORE	LEVER, FRONT BRAKE	LEVIER FREIN AVANT	BREMSHEBEL VORNE	PALANCA FRENO DELANTERO
TE	2	8000A4564	1	LEVA FRENO ANTERIORE	LEVER, FRONT BRAKE	LEVIER FREIN AVANT	BREMSHEBEL VORNE	PALANCA FRENO DELANTERO
TC	3	8000A4565	1	CAVALLOTTO POMPA FRENO	BRACKET, MASTER CYLINDER	BRIDE MAITRE CYLINDRE	KONSOLE, HAUPTBREMSZYLINDER	BRIDA BOMBA FRENO
TE	3	8000A4568	1	CAVALLOTTO POMPA FRENO	BRACKET, MASTER CYLINDER	BRIDE MAITRE CYLINDRE	KONSOLE, HAUPTBREMSZYLINDER	BRIDA BOMBA FRENO
	4	800094126	1	COPERCHIO VASCHETTA LIQUIDO FRENI	COVER MASTER CYLINDER	COUVERCLE RESERVOIR LIQUIDE FREIN	VERSCHLUSS BREMSFLUESSIGKEITANK	TAPON DEPOSITO LIQUIDO FRENOS
	5	800094127	1	PERNO LEVA FRENO	BOLT, HANDLE LEVER PIVOT	PIVOT LEVIER FREIN	HEBELSCHRAUBE KPL.	PERNO PALANCA FRENO
	6	800094128	1	SOFFIETTO POMPA FRENO	DUST COVER	SOUFFLET EN CAOUTCHOUC	GUMMIBALG	FUELLE GOMA
	7	800079099	1	ANTIEMULSIONANTE	ANTIEMULSION	ANTIEMULSION	EMULSIONWIDRIGER	ANTIEMULSION
TC-TXC	8	8A0093036	1	TUBO FRENO ANTERIORE	HOSE, FRONT BRAKE	TUYAU FREIN AVANT	BREMSSCHLAUCH VORNE	MANGUERA FRENO DELANTERO
TE	8	8A00A6242	1	TUBO FRENO ANTERIORE	HOSE, FRONT BRAKE	TUYAU FREIN AVANT	BREMSSCHLAUCH VORNE	MANGUERA FRENO DELANTERO
	9	8000A9349	1	VITE REGISTRO LEVA	ADJUSTING SCREW	VIS REGLAGE	EINSTELLSCHRAUBE	TORNILLO REGULACION
	11	8000A5992	1	PINZA FRENO ANTERIORE	CALIPER, FRONT BRAKE	ETRIER FREIN AVANT	BREMSSATTEL, VORNE	PINZA FRENO DELANTERO
	12	8A0062733	2	VITE TE M8X1,25X40	SCREW TE M8X1,25X40	VIS TE M8X1,25X40	SCHRAUBE TE M8X1,25X40	TORNILLO TE M8X1,25X40
	14	800071445	1	LIQUIDO FRENI	BRAKE FLUID	LIQUIDE FREIN	BREMSFLUESSIGKEIT	LIQUIDO FRENO
TE NO USA	15	8000A0929	1	INTERRUTTORE STOP	SWITCH, STOP	INTERRUPTEUR STOP	STOPSCHALTER	INTERRUPTOR STOP
	16	800049654	1	VETRINO SPIA LIVELLO OLIO	WINDOW, OIL LEVEL CHECK	HUBLOT NIVEAU HUILE	SCHAUGLAS, OELKONTROLL	MIRILLA NIVEL ACEITE
	17	8000A7143	1	COPPIA PASTIGLIE FRENO ANTERIORE	PADS SET, FRONT BRAKE	JEU PLAQUETTES FREIN AVANT	VORNEBREMSBELAEGESATZ	JUEGO PASTILLAS FRENO DELANTERO
	18	8000A0932	1	GRUPPO REVISIONE PERNI PASTIGLIE FRENO	PAD PINS OVERHAUL SET	GROUPE REVISION PIVOTS PLAQUETTE	BREMSBELAEGEN EBERHOLUNGSGRUPPE	GRUPO REVISION PERNO PASTILLAS FRENO
	19	8000A0931	1	VITE SPURGO PINZA FRENO	BLEED SCREW KIT	VIS VIDANGE ETRIER FREIN	SCHRAUBE, BREMSSATTEL ABLASS	TORNILLO PURGA PINZA FRENO
	20	800053259	1	CAPPUCCIO VITE SPURGO	CAP, BLEEDER SCREW	CAPUCHON VIS RENIFLARD	ENTLUEFTUNGSKAPPE	CAPUCHON TORNILLO PURGA PINZA
	21	8000A7144	1	MOLLETTE PASTIGLIE FRENO	SUPPORT, PAD	RESSORT PLAQUETTE FREIN	FEDER, BREMSESEIBE	MUELLE PASTILLAS
	22	800079066	1	SERIE SILENTBLOCK PINZA FRENO	CAPS OVERHAUL SET	GROUPE REVISION CAPOUCHONS	GUMMIUBERARBITUNGSAZ	GRUPO REVISION GORRO
	23	800057155	2	VITE RACCORDO TUBO M10X1,00X19	BOLT, BRAKE HOSE M10X1,00X19	VIS FIXATION TUYAU M10X1,00X19	FIXIERSCHRAUBE M10X1,00X19	TORNILLO FIJACION MANGUERA M10X1,00X19
	24	800021480	4	RONDELLA 14X10,2X1 MM	WASHER 14X10,2X1 MM	RONDELLE 14X10,2X1 MM	SCHEIBE 14X10,2X1 MM	ARANDELA 14X10,2X1 MM
	26	8000A1138	1	PISTONCINO PINZA FRENO	PISTON, CALIPER	PISTON ETRIER FREIN	KOLBEN BREMSSATTEL	PISTON PINZA FRENO
	27	8000A1139	1	SERIE GUARNIZIONI PINZA FRENO	BRAKE CALIPER OVERHAUL SET	JEU JOINTS ETRIER DU FREIN	BREMSSATTEL EBERHOLUNGSSATZ	JUEGO JUNTAS PINZA FRENO
	37	800062729	2	VITE TEF M6X1X25 CH8	SCREW TEF M6X1X25 CH8	VIS TEF M6X1X25 CH8	SCHRAUBE TEF M6X1X25 CH8	TORNILLO TEF M6X1X25 CH8
	38	8000A7145	1	SUPPORTO PINZA FRENO ANTERIORE	BRACKET, FRONT CALIPER	SUPPORT ETRIER FREIN AVANT	HALTERUNG, VORNEBREMSSESATTEL	SOPORTE PINZA FRENO DELANTERO
	39	8000A9350	1	PISTONCINO POMPA FRENO	CYLINDER KIT, MASTER	PISTON MAITRE CYLINDRE	KOLBEN, BREMSEPUMPE	PISTON BOMBA FRENO
	40	800056377	1	RONDELLA 16X8,3X1	WASHER 16X8,3X1	RONDELLE 16X8,3X1	SCHEIBE 16X8,3X1	ARANDELA 16X8,3X1





**FRENO IDRAULICO ANTERIORE - FRONT HYDRAULIC BRAKE**  
**FREIN HYDRAULIQUE AVANT - VORDERBREMSE**  
**FRENO HIDRAULICO DELANTERO**

Note Notes Notas	Pos. No. Index Pos.	N. Cod. Code No. Nr. Code Code Nr N. Cod.	Q.tà Q.ty Q.te M.ge C.ad	DENOMINAZIONE	NAME	DESIGNATION	BESHREIBUNG	DENOMINACION
	1	8000A6076	1	POMPA FRENO ANTERIORE	CYLINDER, FRONT MASTER	MAITRE CYLINDRE FREIN AVANT	HAUPTZYLINDER, VORNE	BOMBA FRENO DELANTERO
	2	8000A7146	1	LEVA FRENO ANTERIORE	LEVER, FRONT BRAKE	LEVIER FREIN AVANT	BREMSHEBEL VORNE	PALANCA FRENO DELANTERO
	3	8000A7148	1	GRUPPO REVISIONE PERNO LEVA	LEVER PIN SET	GROUPE REVISION PIVOT LEVIER	HEBELBOLZENGRUPPE	GRUPO REVIS. PERNO PALANCA
	4	800042345	1	RACCORDO TUBO OLIO	UNION, HOSE	JOINT TUYAU	VERBINDUNG, SCHLAUCH	RACOR MANGUITO
	5	8000A7147	1	CAVALLOTTO POMPA FRENO	BRACKET, MASTER CYLINDER	BRIDE MAITRE CYLINDRE	KONSOLE, HAUPTBREMSZYLINDER	BRIDA BOMBA FRENO
	6	8S0082751	2	VITE TCEIF M10X1,25X55	SCREW TCEIF M10X1.25X55	VIS TCEIF M10X1,25X55	SCHRAUBE TCEIF M10X1,25X55	TORNILLO TCEIF M10X1,25X55
	7	800066181	1	VASCHETTA LIQUIDO FRENI	RESERVOIR, BRAKE FLUID	RESERVOIR LIQUIDE FREINS	BREMSFLUESSIGKEITTANK	DEPOSITO LIQUIDO FRENO
	8	800068490	1	TAPPO VASCHETTA LIQUIDO FRENI	CAP BRAKE FLUID TANK	BOUCHON RESERVOIR LIQUIDE FREIN	VERSCHLUSS BREMSFLUESSIGKEITTANK	TAPON DEPOSITO LIQUIDO FRENO
	9	800033288	1	SILENTBLOCK 20X10X13	DAMPER 20X10X13	SILENTBLOC 20X10X13	SCHWINGSDAEMPFER 20X10X13	CASQUILLO ELASTICO 20X10X13
	10	8000A6229	1	PIASTRINA	PLATE	PLAQUETTE	PLAETTCHEN	PLETINA
	11	8000A1189	1	VITE TTEI M5X16	SCREW TTEI M5X16	VIS TTEI M5X16	SCHRAUBE TTEI M5X16	TORNILLO TTEI M5X16
	12	800062725	1	VITE TEF M6X1,00X10 CH8	SCREW TEF M6X1.00X10 CH8	VIS TEF M6X1,00X10 CH8	SCHRAUBE TEF M6X1,00X10 CH8	TORNILLO TEF M6X1,00X10 CH8
	13	8G0066179	1	TUBO OLIO	HOSE, OIL	TUYAU HUILE	OELSCHLAUCH	MANGUERA ACEITE
	14	800018921	2	ANELLO ELASTICO 10 MM	CIRCLIP 10 MM	BAGUE ELASTIQUE 10 MM	SPRENGRING 10 MM	ANILLO ELASTICO 10 MM
	15	800062729	2	VITE TEF M6X1X25 CH8	SCREW TEF M6X1X25 CH8	VIS TEF M6X1X25 CH8	SCHRAUBE TEF M6X1X25 CH8	TORNILLO TEF M6X1X25 CH8
	16	8000A3975	1	VITE RACCORDO TUBO OLIO	BOLT, OIL PIPE	VIS FIXATION TUYAU HUILE	FIXIERSCHRAUBE OELSCHLAUCH	TORNILLO FIJACION TUBO ACEITE
	17	800053259	1	CAPPUCCIO VITE SPURGO	CAP, BLEEDER SCREW	CAPUCHON VIS RENIFLARD	ENTLUEFTUNGSKAPPE	CAPUCHON TORNILLO PURGA PINZA
	18	800056443	1	DADO AUTOBLOCCANTE M5X0,8 CH8	NUT, SELF LOCKING M5X0.8 CH8	ECROU AUTOBLOQUANT M5X0,8 CH8	SELBSTSPERRENDE MUTTER M5X0,8 CH8	TUERCA AUTOBLOQUEANTE M5X0,8 CH8
	19	8000A0929	1	INTERRUTTORE STOP	SWITCH, STOP	INTERRUPTEUR STOP	STOPSCHALTER	INTERRUPTOR STOP
	20	8A00A1706	1	TUBO FRENO ANTERIORE	HOSE, FRONT BRAKE	TUYAU FREIN AVANT	VORDERBREMSSCHLAUCH	MANGUERA FRENO DELANTERO
	21	800057155	1	VITE RACCORDO TUBO M10X1,00X19	BOLT, BRAKE HOSE M10X1.00X19	VIS FIXATION TUYAU M10X1,00X19	FIXIERSCHRAUBE M10X1,00X19	TORNILLO FIJACION MANGUERA M10X1,00X19
	22	800021480	4	RONDELLA 14X10,2X1 MM	WASHER 14X10.2X1 MM	RONDELLE 14X10,2X1 MM	SCHEIBE 14X10,2X1 MM	ARANDELA 14X10,2X1 MM
	25	8000A6078	1	PINZA FRENO ANTERIORE	CALIPER, FRONT BRAKE	ETRIER FREIN AVANT	BREMSSATTEL, VORNE	PINZA FRENO DELANTERO
	26	8000A2040	1	COPIA PASTIGLIE FRENO ANTERIORE	PADS SET, FRONT BRAKE	JEU PLAQUETTES FREIN AVANT	VORNEBREMSBELAEGESATZ	JUEGO PASTILLAS FRENO DELANTERO
	32	800071445	1	LIQUIDO FRENI	BRAKE FLUID	LIQUIDE FREIN	BREMSFLUESSIGKEIT	LIQUIDO FRENO

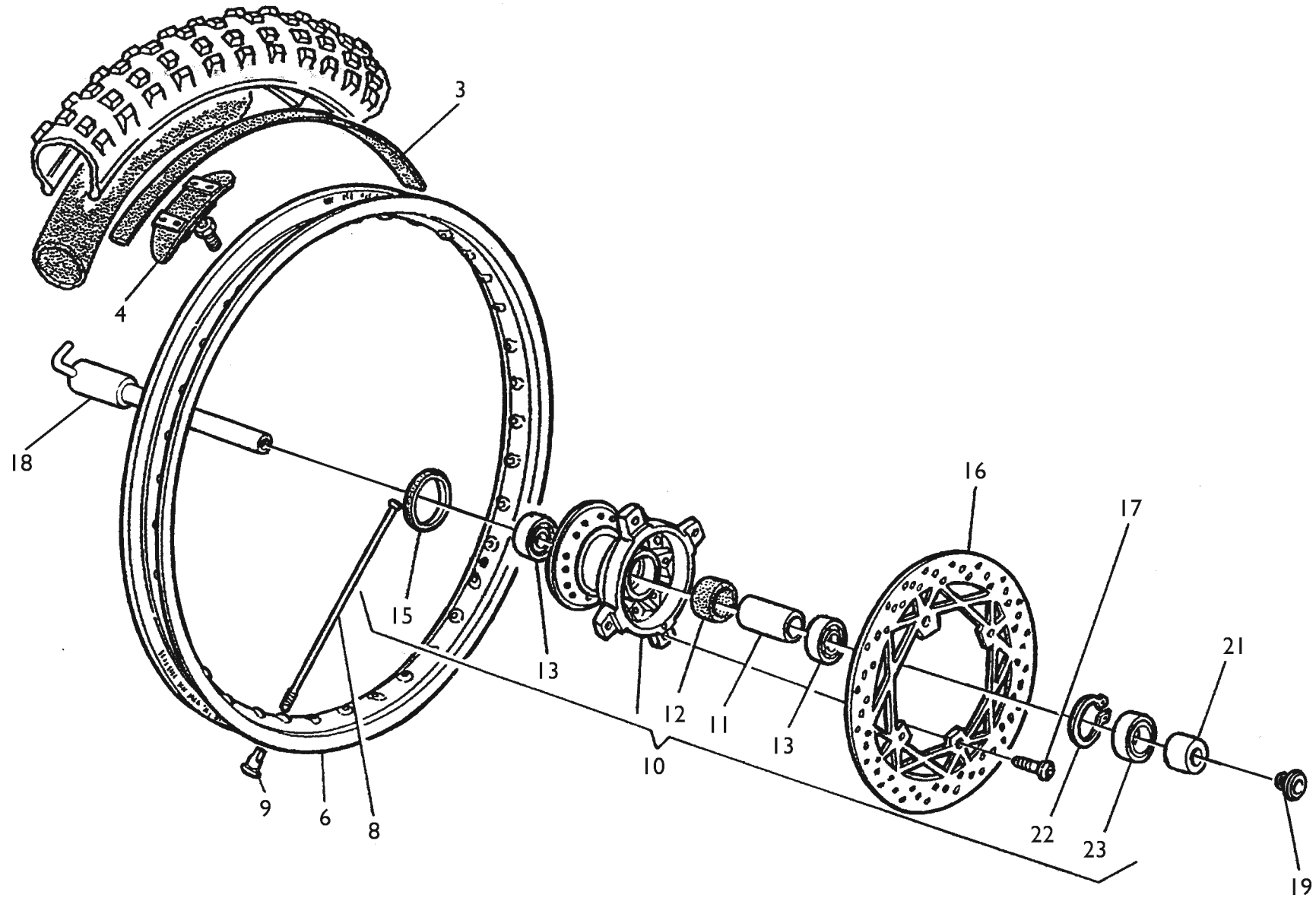

Note Notes Notes Marke Notas	Pos. No. N. Index Pos.	N. Cod. Code No. Nr. Code Code Nr N. Cod.	Q.tà Q.ty Q.te M.ge C.ad	DENOMINAZIONE	NAME	DESIGNATION	BESHREIBUNG	DENOMINACION
	3	800013346	1	FASCIA SALVACAMERA	PROTECTOR, INNER TUBE	FOND JANTE	FELGENBAND	PROTECTOR CAMARA
	4	800049036	1	FERMACOPERTONE	TIRE BLEND CLAMP	PLAQUE ARRET PNEU	REIFEN FIXIERPLATTE	PLACA SUJECION NEUMATICO
TC	6	8AB053504	1	CERCHIO RUOTA ANTERIORE 1,6X21	RIM, FRONT WEHEL 1,6X21	JANTE ROUE AVANT 1,6X21	FELGE, VORDERRAD 1,6X21	LLANTA RUEDA DELANTERA 1,6X21
TE-TXC	6	8A0053504	1	CERCHIO RUOTA ANTERIORE 1,6X21	RIM, FRONT WEHEL 1,6X21	JANTE ROUE AVANT 1,6X21	FELGE, VORDERRAD 1,6X21	LLANTA RUEDA DELANTERA 1,6X21
	8	8000A6207	36	RAGGIO RUOTA ANTERIORE	SPOKE, FRONT WHEEL	RAYON ROUE AVANT	SPEICHE, VORDERRAD	RADIO RUEDA DELANTERA
	9	8000A6208	36	NIPPLO RAGGIO	NIPPLE, SPOKE	ECROU RAYON	NIPPEL, SPEICHE	TUERCA RADIO
	10	800096838	1	MOZZO RUOTA ANTERIORE	HUB, FRONT WHEEL	MOYEU ROUE AVANT	RADNABE, VORNE	CUBO RUEDA DELANTERA
	11	800096928	1	DISTANZIALE INTERNO CUSCINETTI	SPACER, HUB BEARING	ENTRETOISE INTERNE ROULEMENT	KUGELLAGER INNEREABSTANDHALTER	DISTANCIADOR INTERIOR COJINETE
	12	800092797	1	DISTANZIALE	SPACER	ENTRETOISE	ABSTANDHALTER	DISTANCIADOR
	13	800084938	2	CUSCINETTO A SFERE 25X42X9	BEARING, BALL 25X42X9	ROULEMENT A BILLES 25X42X9	KUGELLAGER 25X42X9	COJINETE DE BOLAS 25X42X9
	15	8A0092986	1	PARAOLIO 28X50X5	OIL SEAL 28X50X5	BAGUE D'ETANCHEITE 28X50X5	WELLENDICHTRING 28X50X5	RETEN DE ACEITE 28X50X5
TC	16	800099632	1	DISCO FRENO ANTERIORE	DISC, FRONT BRAKE	DISQUE FREIN AVANT	BREMSSCHEIBE, VORNE	DISCO FRENO DELANTERO
TE-TXC	16	8000A6294	1	DISCO FRENO ANTERIORE	DISC FRONT BRAKE	DISQUE FREIN AVANT	BREMSSCHEIBE, VORNE	DISCO FRENO DELANTERO
	17	8A0055241	4	VITE TCEI M6X1,00X14 CH5	SCREW TCEI M6X1,00X14 CH5	VIS TCEI M6X1,00X14 CH5	SCHRAUBE TCEI M6X1,00X14 CH5	TORNILLO TCEI M6X1,00X14 CH5
TC	18	8B0096932	1	PERNO RUOTA ANTERIORE	AXLE, FRONT WHEEL	AXE ROUE AVANT	VORDERRADACHSE	EJE RUEDA DELANTERA
TE-TXC	18	8B00A2785	1	PERNO RUOTA ANTERIORE	AXLE, FRONT WHEEL	AXE ROUE AVANT	VORDERRADACHSE	EJE RUEDA DELANTERA
	19	800096933	1	VITE M20	SCREW M20	VIS M20	SCHRAUBE M20	TORNILLO M20
	21	8A0096930	1	DISTANZIALE	SPACER	ENTRETOISE	ABSTANDHALTER	DISTANCIADOR
	22	66N021270	1	ANELLO SEEGER INTERNO 42MM DIN472	CIRCLIP 42MM DIN472	CIRCLIP 42MM DIN472	SEEGERRING 42MM DIN472	ANILLO SEEGER 42MM DIN472
	23	800022966	1	PARAPOLVERE 32X42X7	SEAL, DUST 32X42X7	PARE POUSSIERE 32X42X7	STAUBDECKEL 32X42X7	GUARDAPOLVO 32X42X7

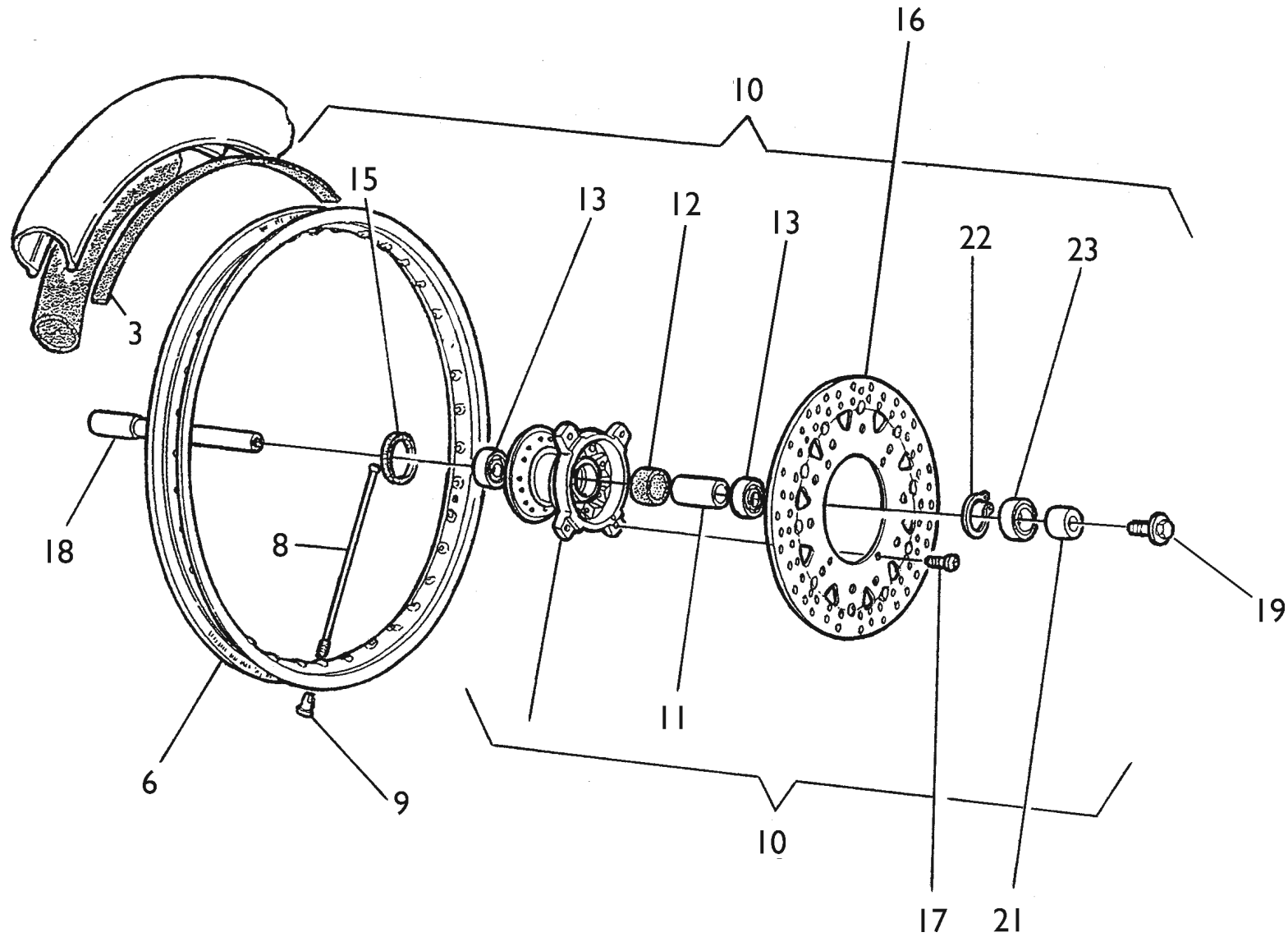

**RUOTA ANTERIORE - FRONT WHEEL  
ROUE AV. - VORTERRAD  
RUEDA DELANTERA**

Note Notes Notes Marke Notas	Pos. No. Index Pos.	N. Cod. Code No. Nr. Code Code Nr N. Cod.	Q.tà Q.ty Q.te M.ge C.ad	DENOMINAZIONE	NAME	DESIGNATION	BESHREIBUNG	DENOMINACION
	3	8B0082879	1	FASCIA SALVACAMERA	PROTECTOR, INNER TUBE	FOND JANTE	FELGENBAND	PROTECTOR CAMARA
	6	80C091525	1	CERCHIO RUOTA ANTERIORE 3,50X17	RIM, FRONT WHEEL 3.50X17	JANTE ROUE AVANT 3,50X17	VORDERERAD FELGE 3,50X17	LLANTA RUEDA DELANTERA 3,50X17
	8	8A0094754	18	RAGGIO RUOTA ANTERIORE LATO DISCO 177 MM	SPOKE, FRONT WHEEL DISC SIDE 177 MM	RAYON ROUE AVANT COTE DISQUE 177 MM	SPEICHE, VORDERRAD SCHEIBE SEITE 177 MM	RADIO RUEDA DELANTERA LATO DISCO 177 MM
	8	800094754	18	RAGGIO RUOTA ANTERIORE 174 MM	SPOKE, FRONT WHEEL 174 MM	RAYON ROUE AVANT 174 MM	SPEICHE, VORDERRAD 174 MM	RADIO RUEDA DELANTERA 174 MM
	9	69N429004	36	NIPPLO RAGGIO	NIPPLE, SPOKE	ECROU RAYON	NIPPEL, SPEICHE	TUERCA RADIO
	10	8B0096838	1	MOZZO RUOTA ANTERIORE	HUB, FRONT WHEEL	MOYEU ROUE AVANT	RADNABE, VORNE	CUBO RUEDA DELANTERA
	11	800096928	1	DISTANZIALE INTERNO CUSCINETTI	SPACER, HUB BEARING	ENTRETOISE INTERNE ROULEMENT	KUGELLAGER INNEREABSTANDHALTER	DISTANCIADOR INTERIOR COJINETE
	12	800092797	1	DISTANZIALE	SPACER	ENTRETOISE	ABSTANDHALTER	DISTANCIADOR
	13	800084938	2	CUSCINETTO A SFERE 25X42X9	BEARING, BALL 25X42X9	ROULEMENT A BILLES 25X42X9	KUGELLAGER 25X42X9	COJINETE DE BOLAS 25X42X9
	15	8A0092986	1	PARAOLIO 28X50X5	OIL SEAL 28X50X5	BAGUE D'ETANCHEITE 28X50X5	WELLENDICHTRING 28X50X5	RETEN DE ACEITE 28X50X5
	16	8000A1709	1	DISCO FRENO ANTERIORE	DISC, FRONT BRAKE	DISQUE FREIN AVANT	BREMSSSCHEIBE, VORNE	DISCO FRENO DELANTERO
	17	8A0092876	4	VITE TTEI M8X1,25X16	SCREW TTEI M8X1.25X16	VIS TTEI M8X1,25X16	SCHRAUBE TTEI M8X1,25X16	TORNILLO TTEI M8X1,25X16
	18	8B0096932	1	PERNO RUOTA ANTERIORE	AXLE, FRONT WHEEL	AXE ROUE AVANT	VORDERRADACHSE	EJE RUEDA DELANTERA
	19	800096933	1	VITE M20	SCREW M20	VIS M20	SCHRAUBE M20	TORNILLO M20
	21	8A0096930	1	DISTANZIALE	SPACER	ENTRETOISE	ABSTANDHALTER	DISTANCIADOR
	22	66N021270	1	ANELLO SEEGER INTERNO 42MM DIN472	CIRCLIP 42MM DIN472	CIRCLIP 42MM DIN472	SEEGERRING 42MM DIN472	ANILLO SEEGER 42MM DIN472
	23	800022966	1	PARAPOLVERE 32X42X7	SEAL, DUST 32X42X7	PARE POUSSIERE 32X42X7	STAUBDECKEL 32X42X7	GUARDAPOLVO 32X42X7

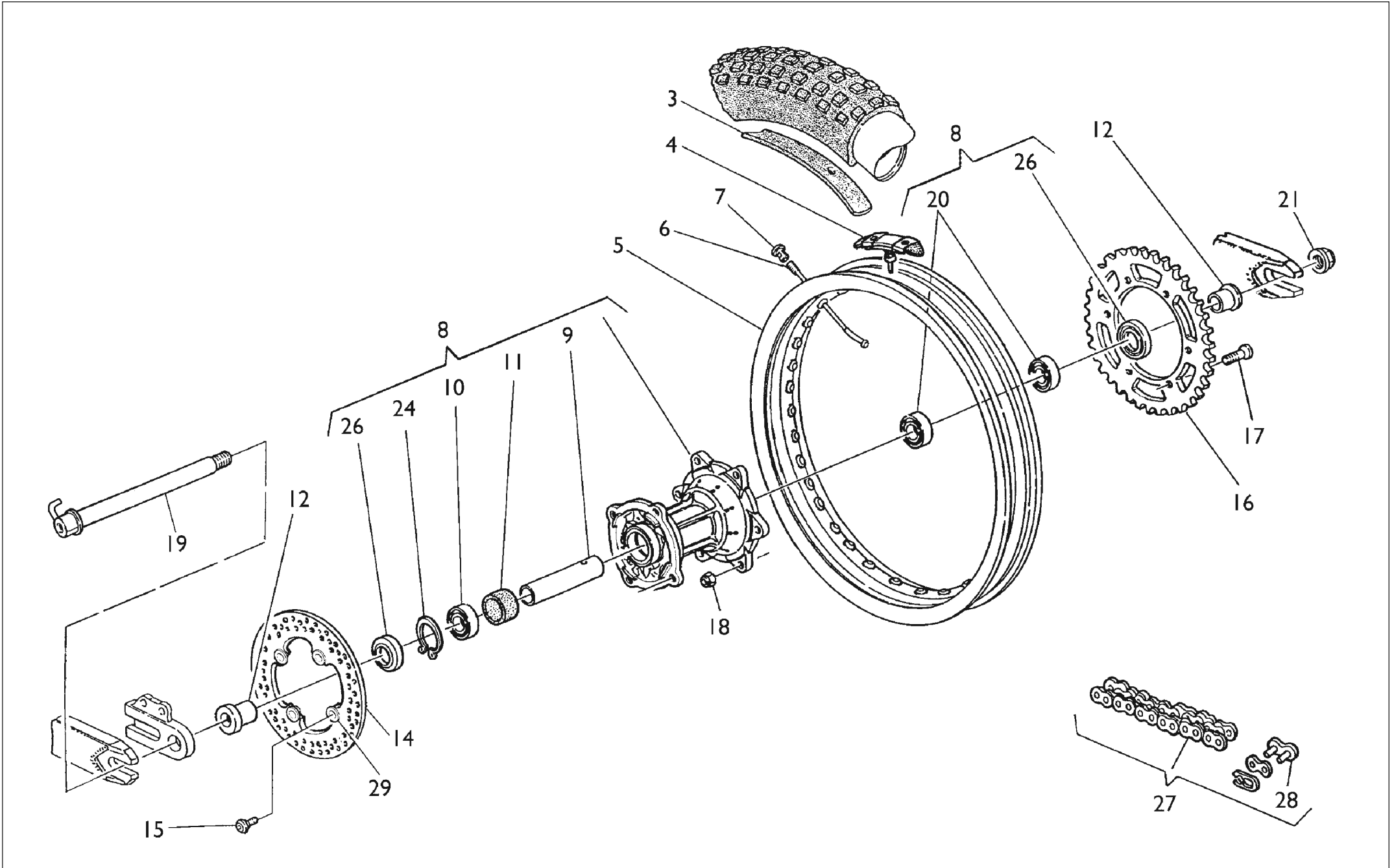

Note Notes Notas	Pos. No. N. Index Pos.	N. Cod. Code No. Nr. Code Code Nr N. Cod.	Q.tà Q.ty Q.te M.ge C.ad	DENOMINAZIONE	NAME	DESIGNATION	BESHREIBUNG	DENOMINACION
SMR	3	8B0082879	1	FASCIA SALVACAMERA	PROTECTOR, INNER TUBE	FOND JANTE	FELGENBAND	PROTECTOR CAMARA
TC	3	800010777	1	FASCIA SALVACAMERA	PROTECTOR, INNER TUBE	FOND JANTE	FELGENBAND	PROTECTOR CAMARA
TE-TXC	3	800001688	1	FASCIA SALVACAMERA	PROTECTOR, INNER TUBE	FOND JANTE	FELGENBAND	PROTECTOR CAMARA
TC 250	4	800049035	1	FERMACOPERTONE	TIRE BLEND CLAMP	PLAQUE ARRET PNEU	REIFEN FIXIERPLATTE	PLACA SUJECION NEUMATICO
TE-TXC-TC 450-510	4	800054073	1	FERMACOPERTONE	TIRE BLEND CLAMP	PLAQUE ARRET PNEU	REIFEN FIXIERPLATTE	PLACA SUJECION NEUMATICO
SMR	5	80C092612	1	CERCHIO RUOTA POSTERIORE 4,25X17	RIM, REAR WHEEL 4,25X17	JANTE ROUE ARRIERE 4,25X17"	FELGE, HINTENRAD 4,25X17"	LLANTA RUEDA TRASERA 4,25X17"
TC 250	5	8AA058930	1	CERCHIO RUOTA POSTERIORE 1,85X19	RIM, REAR WHEEL 1.85X19	JANTE ROUE ARRIERE 1,85X19	FELGE, HINTERRAD 1,85X19	LLANTA RUEDA TRASERA 1,85X19
TC 450-510	5	8AA058929	1	CERCHIO RUOTA POSTERIORE 2,15X19	RIM, REAR WHEEL 2,15X19	JANTE ROUE ARRIERE 2,15X19	FELGE, HINTENRAD 2,15X19	LLANTA RUEDA TRASERA 2,15X19
TE-TXC	5	8A0055860	1	CERCHIO RUOTA POSTERIORE 2,15X18	RIM, REAR WHEEL 2,15X18	JANTE ROUE ARRIERE 2,15X18	FELGE, HINTENRAD 2,15X18	LLANTA RUEDA TRASERA 2,15X18
SMR	6	800094757	18	RAGGIO RUOTA POSTERIORE LATO DISCO	REAR WHEEL SPOKE, DISC SIDE	RAYON ROUE ARRIERE COTE DISQUE	HINTERRADSPEICHE SCHEIBE SEITE	RADIO RUEDA TRASERA LATO DISCO
SMR	6	800095341	18	RAGGIO RUOTA POSTERIORE LATO CORONA	REAR WHEEL SPOKE, SPROCKET SIDE	RAYON ROUE ARRIERE COTE COURONNE	HINTERRADSPEICHE ZAHNKETTENRAD SEITE	RADIO RUEDA TRASERA LATO CORONA
TC	6	8A00A6206	18	RAGGIO RUOTA POSTERIORE 208 MM	SPOKE, REAR WHEEL 208 MM	RAYON ROUE ARRIERE 208 MM	SPEICHE, HINTERRAD 208 MM	RADIO RUEDA TRASERA 208 MM
TC	6	8C00A6206	18	RAGGIO POSTERIORE LATO CORONA 212 MM	SPOKE REAR WHEEL SPROKET SIDE 212 MM	RAYON ROUE ARRIERE COURONNE 212 MM	SPEICHE, HINTERRAD ZAHNKETTEN 212 MM	RADIO RUEDA TRASERA LATO CORONA 212 MM
TC	6	8A00A0085	36	RAGGIO RUOTA POSTERIORE 206 MM	SPOKE, REAR WHEEL 206 MM	RAYON ROUE ARRIERE 206 MM	SPEICHE, HINTERRAD 206 MM	RADIO RUEDA TRASERA 206 MM
TE-TXC	6	8000A6206	18	RAGGIO RUOTA POSTERIORE 194,5 MM	SPOKE, REAR WHEEL 194.5 MM	RAYON ROUE ARRIERE 194,5 MM	SPEICHE, HINTERRAD 194,5 MM	RADIO RUEDA TRASERA 194,5 MM
TE-TXC	6	8B00A6206	18	RAGGIO RUOTA POSTERIORE LATO CORONA	REAR WHEEL SPOKE, SPROCKET SIDE	RAYON ROUE ARRIERE COTE COURONNE	HINTERRADSPEICHE ZAHNKETTENRAD SEITE	RADIO RUEDA TRASERA LATO CORONA
SMR	7	69N429005	36	NIPPLO RAGGIO	NIPPLE, SPOKE	ECROU RAYON	NIPPEL, SPEICHE	TUERCA RADIO
TE-TC-TXC	7	8000A6209	36	NIPPLO RAGGIO ALPINA	NIPPLE, SPOKE ALPINA	ECROU RAYON ALPINA	NIPPEL, SPEICHE ALPINA	TUERCA RADIO ALPINA
SMR	8	8A0097593	1	MOZZO RUOTA POSTERIORE	HUB, REAR WHEEL	MOYEU ROUE ARRIERE	RADNABE, HINTEN	CUBO RUEDA TRASERA
TE-TC-TXC	8	8A0096937	1	MOZZO RUOTA POSTERIORE	HUB, REAR WHEEL	MOYEU ROUE ARRIERE	RADNABE, HINTEN	CUBO RUEDA TRASERA
SMR	9	8A0086938	1	DISTANZIALE INTERNO CUSCINETTI	SPACER, HUB BEARING	ENTRETOISE INTERNE ROULEMENT	KUGELLAGER INNEREABSTANDHALTER	DISTANCIADOR INTERIOR COJINETE
TE-TC-TXC	9	800092414	1	DISTANZIALE INTERNO CUSCINETTI	SPACER, HUB BEARING	ENTRETOISE INTERNE ROULEMENT	KUGELLAGER INNEREABSTANDHALTER	DISTANCIADOR INTERIOR COJINETE
	10	8B0026846	1	CUSCINETTO A SFERE 25X47X16	BEARING, BALL 25X47X16	ROULEMENT A BILLES 25X47X16	KUGELLAGER 25X47X16	COJINETE DE BOLAS 25X47X16
SMR	10	8D0026846	1	CUSCINETTO A SFERE 25X47X16	BALL BEARING 25X47X16	ROULEMENT A BILLES 25X47X16	KUGELLAGER 25X47X16	COJINETE DE BOLAS 25X47X16
	11	800092797	1	DISTANZIALE	SPACER	ENTRETOISE	ABSTANDHALTER	DISTANCIADOR
	12	800096938	2	DISTANZIALE ESTERNO	SPACER, OUTER	ENTRETOISE EXTERIEUR	ABSTANDHALTER, AUSSER	DISTANCIADOR EXTERIOR
TC-SMR	14	8000A4288	1	DISCO FRENO POSTERIORE	DISC REAR BRAKE	DISQUE FREIN ARRIERE	BREMSSCHEIBE, HINTEN	DISCO FRENO TRASERO
TE-TXC	14	8A00A4288	1	DISCO FRENO POSTERIORE	DISC REAR BRAKE	DISQUE FREIN ARRIERE	BREMSSCHEIBE, HINTEN	DISCO FRENO TRASERO

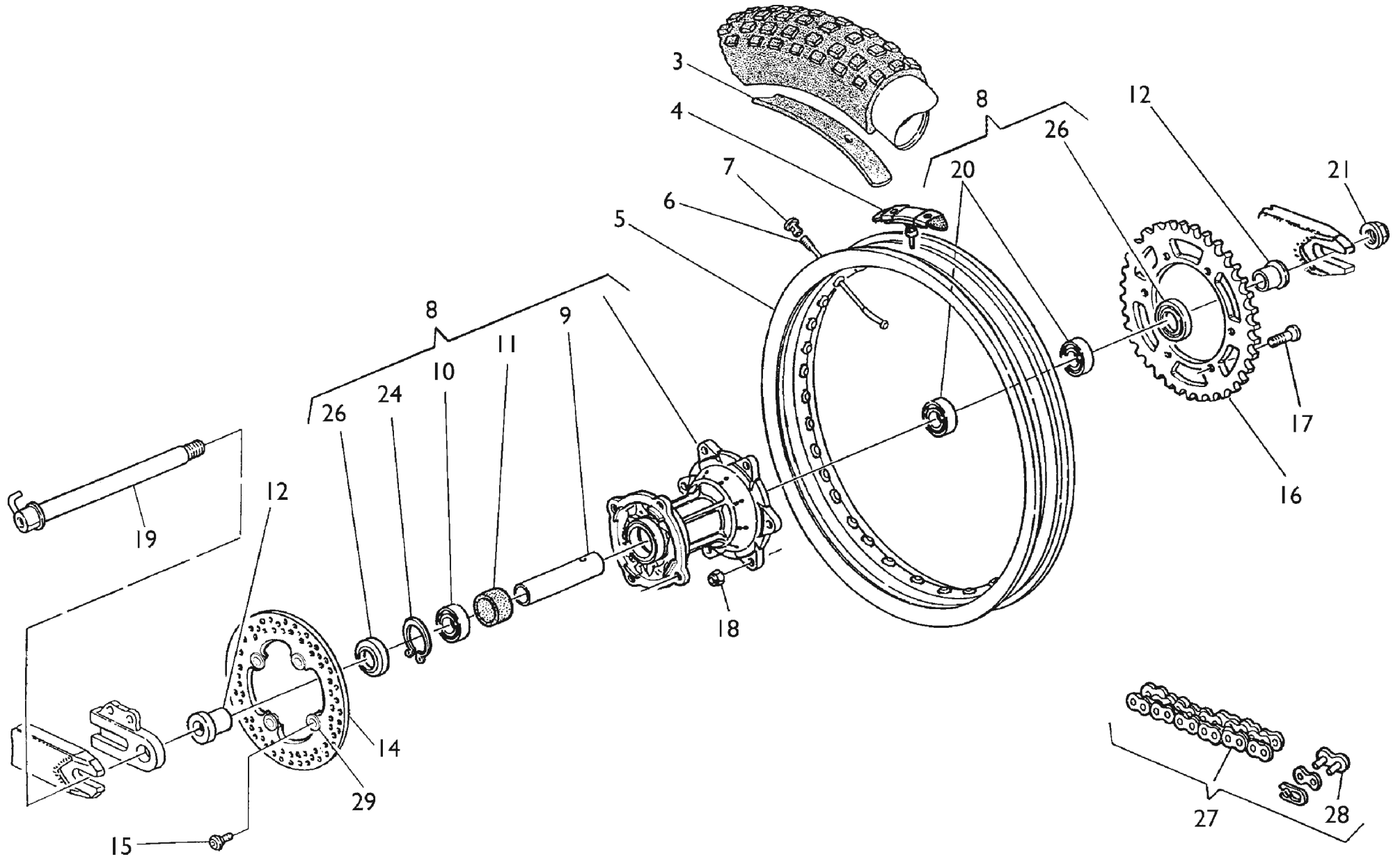



Note Notes Notes Marke Notas	Pos. No. Index Pos.	N. Cod. Code No. Nr. Code Code Nr N. Cod.	Q.tà Q.ty Q.te M.ge C.ad	DENOMINAZIONE	NAME	DESIGNATION	BESHREIBUNG	DENOMINACION
	15	800062726	4	VITE TEF M6X1,00X14 CH8	SCREW TEF M6X1.00X14 CH8	VIS TEF M6X1,00X14 CH8	SCHRAUBE TEF M6X1,00X14 CH8	TORNILLO TEF M6X1,00X14 CH8
	16	8D0096837	1	CORONA Z50	REAR SPROCKET T50	COURONNE D50	ZAHNKETTENRAD Z50	CORONA D50
	16	8G00A4859	1	CORONA Z45	REAR SPROCKET NT.45	COURONNE D45	ZAHNKETTENRAD Z45	CORONA D45
	16	8B00A4859	1	CORONA Z44	REAR SPROCKET T 44	COURONNE D 44	ZAHNKETTENRAD Z 44	CORONA D 44
	16	8B0096837	1	CORONA Z48	REAR SPROCKET T48	COURONNE D48	ZAHNKETTENRAD Z48	CORONA D48
	16	8A00A4859	1	CORONA Z43	REAR SPROCKET T43	COURONNE D43	ZAHNKETTENRAD Z43	CORONA D43
STD 250 TC450-510	16	8C0096837	1	CORONA Z49	REAR SPROCKET 49T	COURONNE D49	ZAHNKETTENRAD Z49	CORONA D49
STD SMR	16	8000A4859	1	CORONA Z42	REAR SPROCKET T42	COURONNE D42	ZAHNKETTENRAD Z42	CORONA D42
STD TE-TXC450-510	16	8A0096837	1	CORONA Z47	REAR SPROCKET T47	COURONNE D47	ZAHNKETTENRAD Z47	CORONA D47
	17	800040796	6	VITE TSEI M8X1,25X25 CH6	SCREW TSEI M8X1.25X25 CH6	VIS TSEI M8X1,25X25 CH6	SCHRAUBE TSEI M8X1,25X25 CH6	TORNILLO TSEI M8X1,25X25 CH6
	18	800043928	6	DADO AUTOBLOCCANTE M8X1,25	NUT, SELF LOCKING M8X1.25	ECROU AUTOBLOQUANT M8X1,25	SELBSTSPERRENDE MUTTER M8X1,25	TUERCA AUTOBLOQUEANTE M8X1,25
TC-SMR	19	800096940	1	PERNO RUOTA POSTERIORE	AXLE, REAR WHEEL	AXE ROUE ARRIERE	HINTERRADACHSE	EJE RUEDA TRASERA
TE-TXC	19	8000A2788	1	PERNO RUOTA POSTERIORE	AXLE, REAR WHEEL	AXE ROUE ARRIERE	HINTERRADACHSE	EJE RUEDA TRASERA
	20	8A0026846	2	CUSCINETTO A SFERE 6005	BEARING, BALL 6005	ROULEMENT A BILLES 6005	KUGELLAGER 6005	COJINETE DE BOLAS 6005
SMR	20	8C0026846	2	CUSCINETTO A SFERE 6005	BEARING, BALL 6005	ROULEMENT A BILLES 6005	KUGELLAGER 6005	COJINETE DE BOLAS 6005
	21	800093072	1	DADO M20X1,5 CH27	NUT M20X1.5 CH27	ECROU M20X1,5 CH27	MUTTER M20X1,5 CH27	TUERCA M20X1,5 CH27
	24	66N021272	1	ANELLO ELASTICO 50,5 MM	CIRCLIP 50.5 MM	CIRCLIP 50,5 MM	SPRENGRING 50,5 MM	ANILLO ELASTICO 50,5 MM
	26	800089572	2	PARAOILIO 32X47X7	OIL SEAL 32X47X7	BAGUE D'ETANCHEITE 32X47X7	WELLENDICHTRING 32X47X7	RETEN DE ACEITE 32X47X7
250	27	8B0079783	1	CATENA DID 5/8X6,5-114	CHAIN DID 5/8X6.5-114	CHAINE DID 5/8X6,5-114	KETTE DID 5/8X6,5-114	CADENA DID 5/8X6,5-114
SMR	27	8D00A7561	1	CATENA CZ 5/8X1/4-106	CHAIN CZ 5/8X1/4-106	CHAINE CZ 5/8X1/4-106	KETTE CZ 5/8X1/4-106	CADENA CZ 5/8X1/4-106
TC	27	800056768	1	CATENA REGINA 135RX-114	CHAIN REGINA 135RX-114	CHAINE REGINA 135RX-114	KETTE REGINA 135RX-114	CADENA REGINA 135RX-114
TC	27	8B0079785	1	CATENA DID 520DS 5/8X6,5-114	CHAIN DID 520DS 5/8X6.5-114	CHAINE DID 520DS 5/8X6,5-114	KETTE DID 520DS 5/8X6,5-114	CADENA DID 520DS 5/8X6,5-114
TE-TXC	27	8E0079783	1	CATENA DID 5/8X6,5-112	CHAIN DID 5/8X6.5-112	CHAINE DID 5/8X6,5-112	KETTE DID 5/8X6,5-112	CADENA DID 5/8X6,5-112
TE-TXC	27	8C00A9233	1	CATENA DID MXV 5/8X1/4-114	CHAIN DID MXV 5/8X1/4-114	CHAINE DID MXV 5/8X1/4-114	KETTE DID MXV 5/8X1/4-114	CADENA DID MXV 5/8X1/4-114
TE-TXC	27	8B00A7561	1	CATENA CZ 5/8X1/4-114	CHAIN CZ 5/8X1/4-114	CHAINE CZ 5/8X1/4-114	KETTE CZ 5/8X1/4-114	CADENA CZ 5/8X1/4-114
TE-TXC	27	8B00A6261	1	CATENA REGINA 5/8X1/4-114	CHAIN REGINA 5/8X1/4-114	CHAINE REGINA 5/8X1/4-114	KETTE REGINA 5/8X1/4-114	CADENA REGINA 5/8X1/4-114
TE-TXC 450-510	27	8A00A7561	1	CATENA CZ 5/8X1/4-112	CHAIN CZ 5/8X1/4-112	CHAINE CZ 5/8X1/4-112	KETTE CZ 5/8X1/4-112	CADENA CZ 5/8X1/4-112

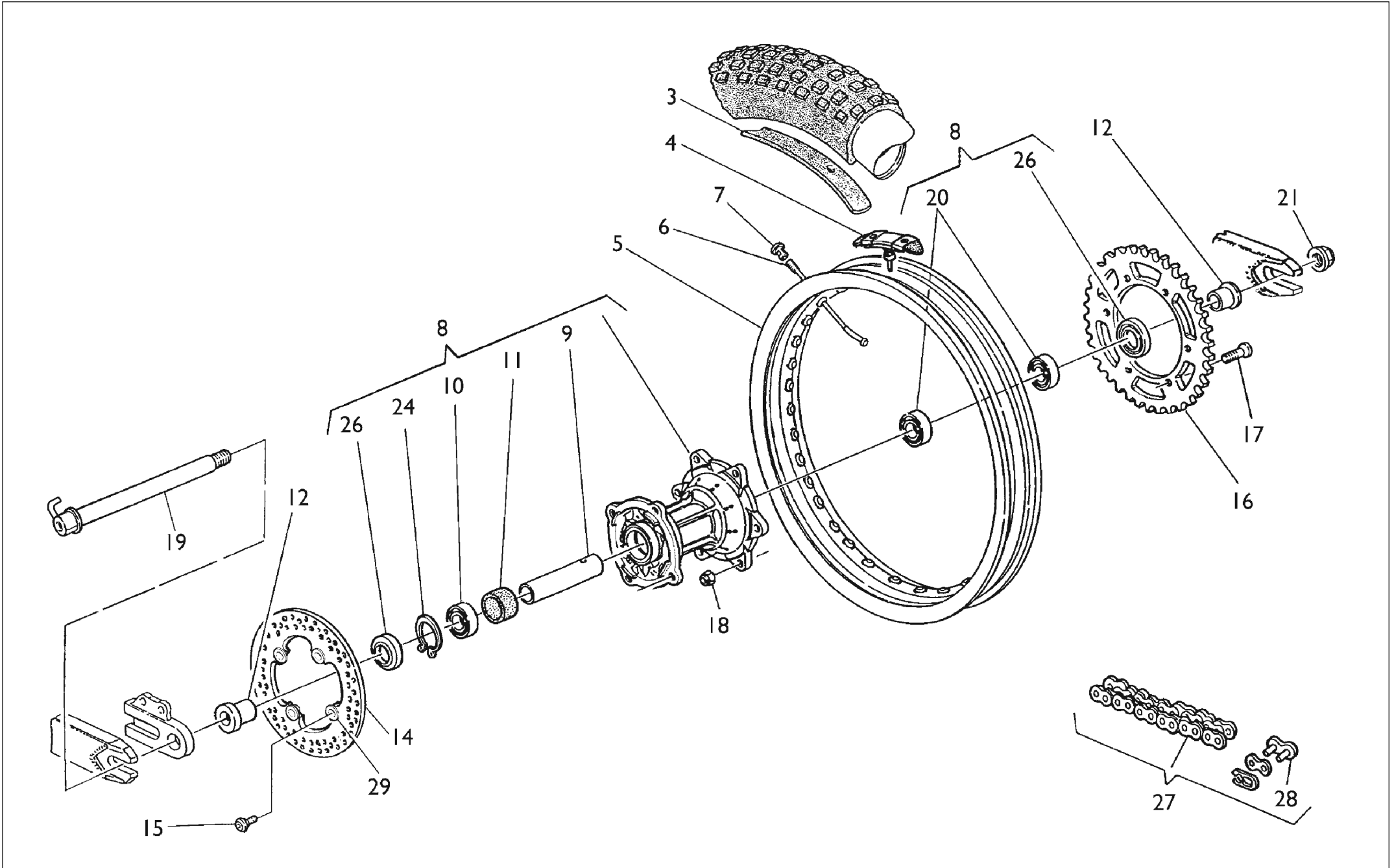



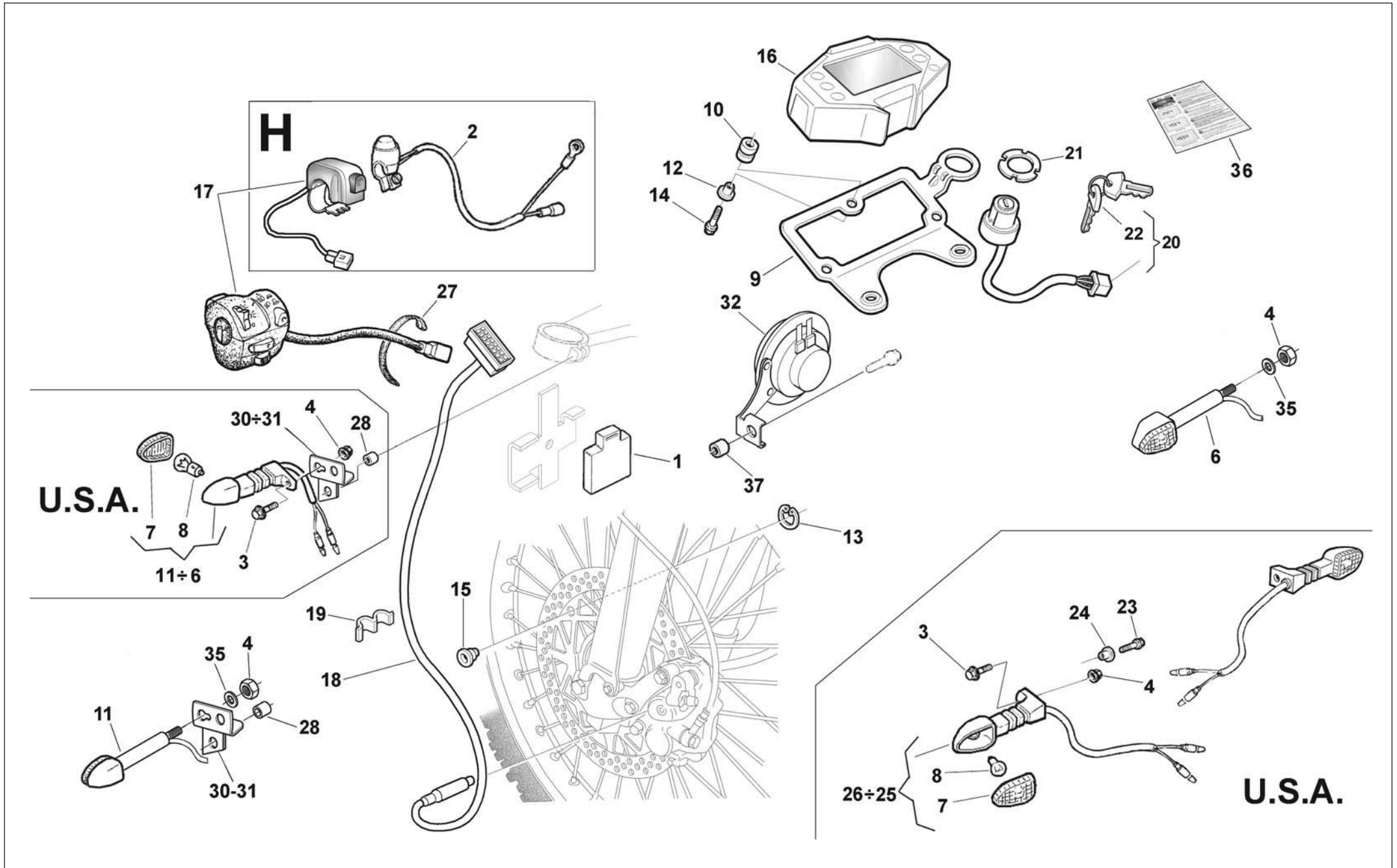

Note Notes Marke Notas	Pos. No. N. Index Pos.	N. Cod. Code No. Nr. Code Code Nr N. Cod.	Q.tà Q.ty Q.te M.ge C.ad	DENOMINAZIONE	NAME	DESIGNATION	BESHREIBUNG	DENOMINACION
RACING, NO USA	1	8000A0645	1	INTERMITTENZA LAMPEGGIATORI	FLASHER RELAY	RELAIS CLIGNOTANTS	BLINKERRELAIS	RELE INTERMITENTES
	2	800094145	1	PULSANTE CLAXON	HORN BUTTON	POUSSOIR AVERTISSEUR SONORE	HUPENDRUCKKNOPF	BOTON BOCINA
USA	3	800062727	4	VITE TE M6X1X16 CH8	SCREW TE M6X1X16 CH8	VIS TE M6X1X16 CH8	SCHRAUBE TE M6X1X16 CH8	TORNILLO TE M6X1X16 CH8
	4	800044240	4	DADO AUTOBLOCCANTE M6X1 CH10	NUT, SELF LOCKING M6X1 CH10	ECROU AUTOBLOQUANT M6X1 CH10	SELBSTSPERRENDE MUTTER M6X1 CH10	TUERCA AUTOBLOQUEANTE M6X1 CH10
	6	8000A5730	2	LAMPEGGIATORE ANT.DX/POST SX	FLASHER LIGHT FRONT RH - REAR LH	CLIGNOTANT AVANT DROIT-ARRIERE GAUCHE	BLINKER, VORDER RECHTS RUECK LINKS	INTERMITENTE DEL.DERECHO-TRASERO IZQ.
USA	6	800078337	1	LAMPEGGIATORE ANTERIORE DESTRO	FRONT FLASHER LIGHT RH	CLIGNOTANT AVANT DROITE	BLINKERLEUCHTE, VORNE RECHTS	INTERMITENTE DELANTERO DERECHO
USA	7	800074507	4	LENTE LAMPEGGIATORE	LENS FLASHER LIGHT	CABOCHON, CLIGNOTANT	BLINKSRGLAS	CRISTAL INTERMITENTE
USA	8	800036726	4	LAMPADINA 12V 10W BA15S	BULB 12V 10W BA15S	AMPOULE 12V 10W BA15S	GLHUELAMPE 12V 10W BA15S	LAMPARA 12V 10W BA15S
NO USA	9	8000A7197	1	SUPPORTO STRUMENTI	BRACKET METER	SUPPORT TABLEAU BORD	HALTERUNG INSTRUMENTENBRETT	SOPORTE TABLERO INSTRUMENTOS
NO USA	10	800095128	3	GOMMINO	GROMMET	CAOUTCHOUC	GUMMITEILE	GOMA
	11	8000A5731	2	LAMPEGGIATORE ANT.SX/POST.DX	FLASHER LIGHT FRONT LH - REAR RH	CLIGNOTANT AVANT GAUCHE-ARRIERE DROIT	BLINKER, VORDER LINKS RUECK RECHTS	INTERMITENTE DEL.IZQUER-TRASERO DERECHO
USA	11	800078338	1	LAMPEGGIATORE ANTERIORE SINISTRO	FRONT FLASHER LIGHT LH	CLIGNOTANT AVANT GAUCHE	BLINKERLEUCHTE, VORNE LINKS	INTERMITENTE DELANTERO IZQUERDO
NO USA	12	8000B1774	3	BOCCOLA	BUSH 14X7X5.25 MM	DOUILLE 14X7X5,25 MM	BUCHSE 14X7X5,25 MM	BUJE 14X7X5,25 MM
SMR NO USA	13	66N021197	1	ANELLO SEEGER	CIRCLIP	CIRCLIP	SEEGERRING	ANILLO SEEGER
TE NO USA	13	66N021200	1	ANELLO SEEGER	CIRCLIP	CIRCLIP	SEEGERRING	ANILLO SEEGER
NO USA	14	8A0067997	3	VITE TEF M5X0,8X16	SCREW TEF M5X0,8X16	VIS TEF M5X0,8X16	SCHRAUBE TEF M5X0,8X16	TORNILLO TEF M5X0,8X16
SMR NO USA	15	8000A0843	1	MAGNETE	MAGNET	AIMANT	MAGNET	IMAN
TE NO USA	15	800099775	1	MAGNETE	MAGNET	AIMANT	MAGNET	IMAN
SMR-TE NO USA	16	8000A6769	1	TACHIMETRO	SPEEDOMETER ASSY	COMPTEUR DE VITESSE	TACHOMETER	VELOCIMETRO
NO USA	17	800099721	1	COMMUTATORE LUCI SINISTRO	HANDLE SWITCH, LEFT	COMMUTATEUR FEUX GAUCHE	LINKER LENKERSCHALTER	CONMUTADOR LUCES IZQUERDO
RACING NO USA	17	8000A9152	1	COMMUTATORE LUCI SINISTRO	SWITCH ASSY, HANDLE, LH	COMMUTATEUR FEUX GAUCHE	LINKS LENKERSCHALTER	CONMUTADOR LUCES IZQUERDO
NO USA	18	8A0099652	1	SENSORE VELOCITA'	SENSOR, SPEED	CAPTEUR VITESSE	ABTASTER GESCHWINDICKEIT	SENSOR VELOCIDAD
NO USA	19	8000A0664	2	MOLLETTA	CLAMP, WIRING	COLLIER, CORDON	KABELKLEMME	GRAMPA CORDON
	20	8000A8903	1	COMMUTATORE A CHIAVE	MAIN SWITCH	COMMUTATEUR A CLE ALLUMAGE	ZUENDSCHALTER	CONMUTADOR LLAVE
	21	800074258	1	GHIERA COMMUTATORE A CHIAVE	RIM, MAIN SWITCH	CACHE COMMUTATEUR	RING, ZUENDSCHALTER	VIOLA CONMUTADOR LLAVE
	22	800035531	2	CHIAVE GREZZA	KEY, BLANK	CLE PAS CRANTEE	SCHLUSSEL NICHT GEZACKT	LLAVE SEMIACABADA
	23	800062726	2	VITE TEF M6X1,00X14 CH8	SCREW TEF M6X1,00X14 CH8	VIS TEF M6X1,00X14 CH8	SCHRAUBE TEF M6X1,00X14 CH8	TORNILLO TEF M6X1,00X14 CH8
	24	800045495	2	BOCCOLA	BUSH	DOUILLE	BUCHSE	BUJE
USA	25	800078340	1	LAMPEGGIATORE POSTERIORE SINISTRO	REAR FLASHER LIGHT LH	CLIGNOTANT ARRIERE GAUCHE	BLINKERLEUCHTE, HINTEN LINKS	INTERMITENTE TRASERO IZQUERDO
USA	26	800078339	1	LAMPEGGIATORE POSTERIORE DESTRO	REAR FLASHER LIGHT RH	CLIGNOTANT ARRIERE DROIT	BLINKERLEUCHTE, HINTEN RECHTS	INTERMITENTE TRASERO DERECHO
	27	800071578	2	FASCETTA 78 MM	CLAMP 78 MM	COLLIER 78 MM	SHELLE 78 MM	ABRAZADERA 78 MM
TE-SMR 450-510	28	8000A6638	2	DISTANZIALE	SPACER	ENTRETOISE	ABSTANDHALTER	DISTANCIADOR
TE-SMR 450-510	30	8000A6642	1	SUPPORTO LAMPEGGIATORE DESTRO	BRACKET, RH FLASHER LIGHT	SUPPORT CLIGNOTANT DROITE	BLINKER HALTERUNG, RECHTS	SOPORTE INTERMITENTE DERECHO

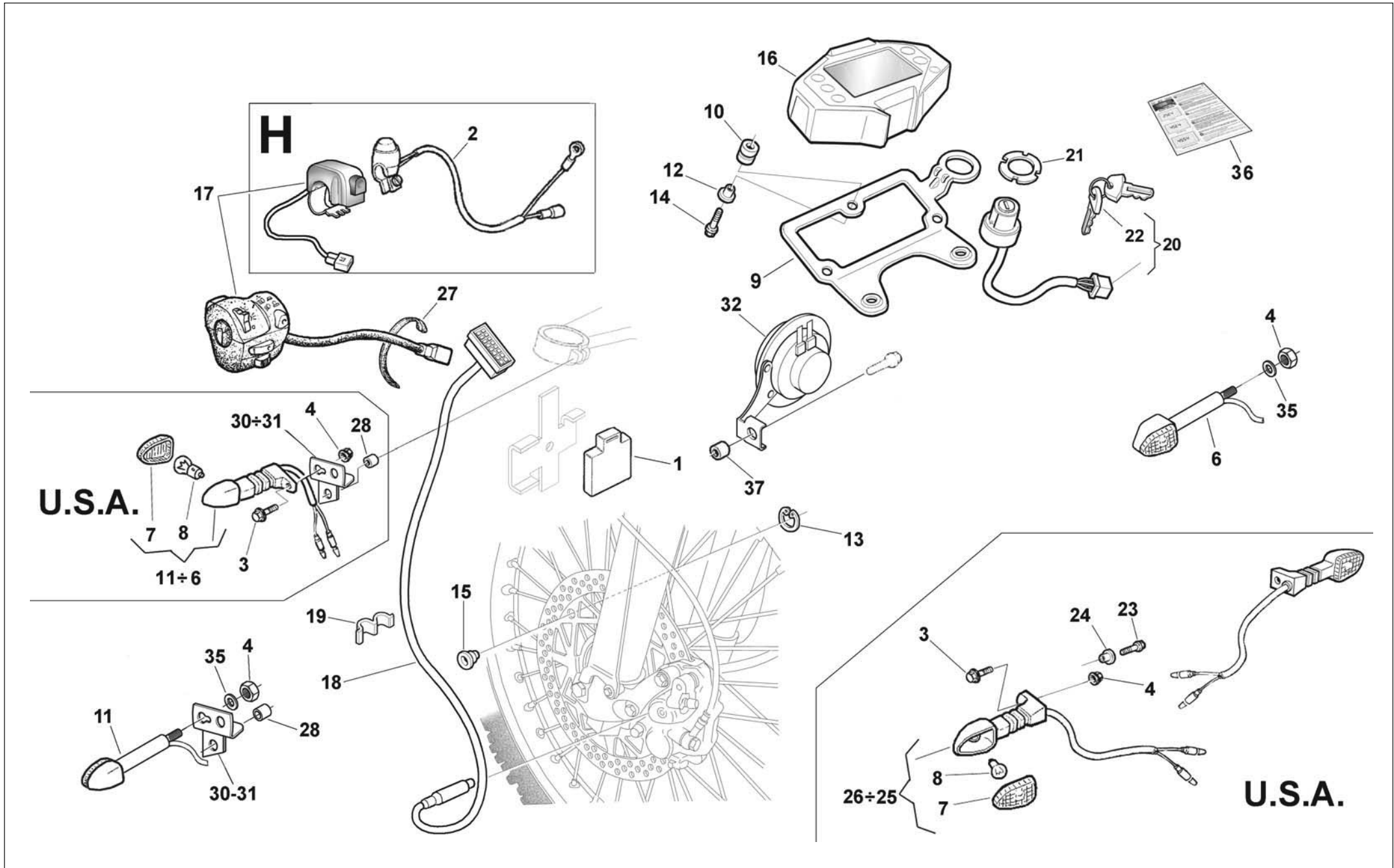



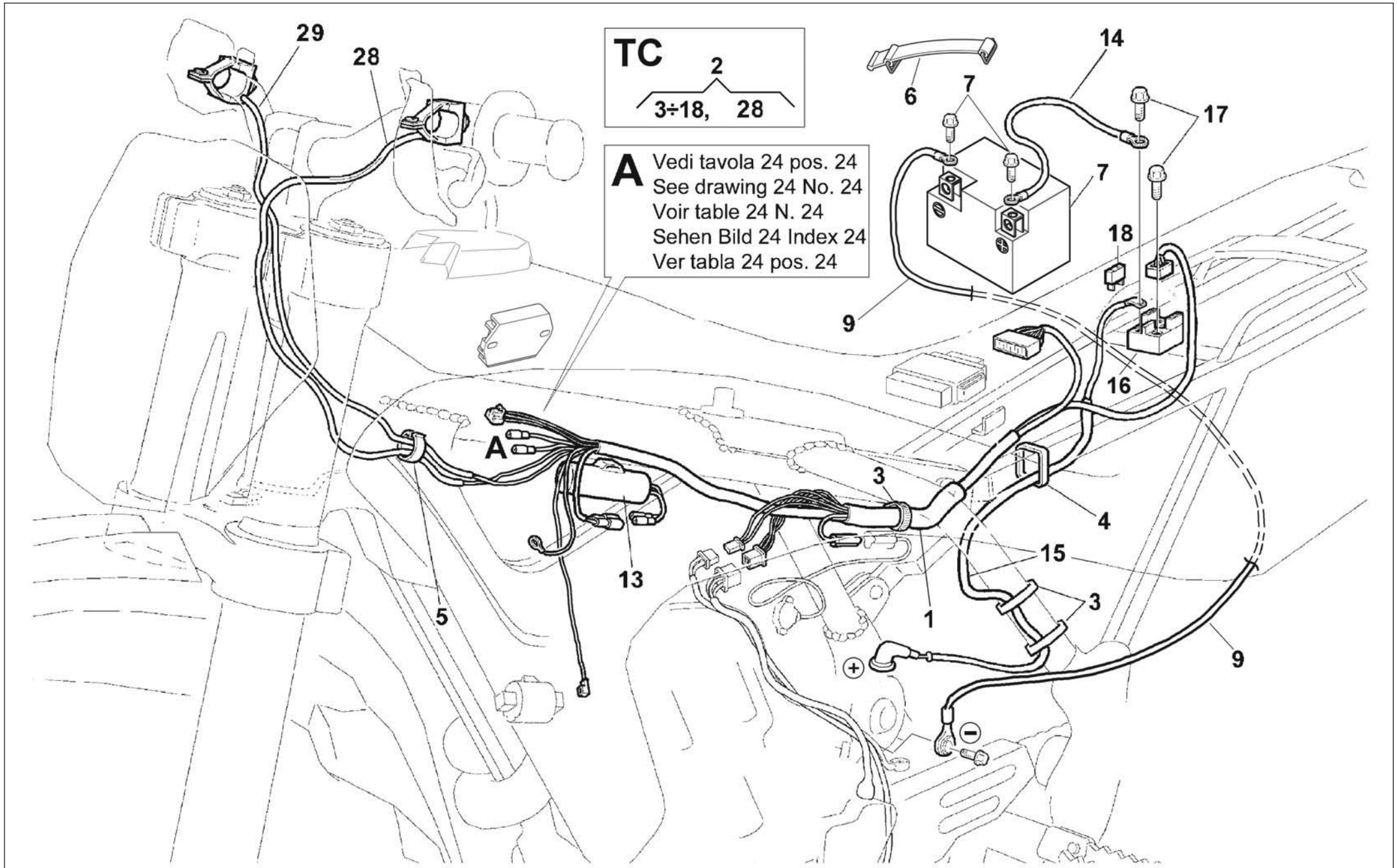





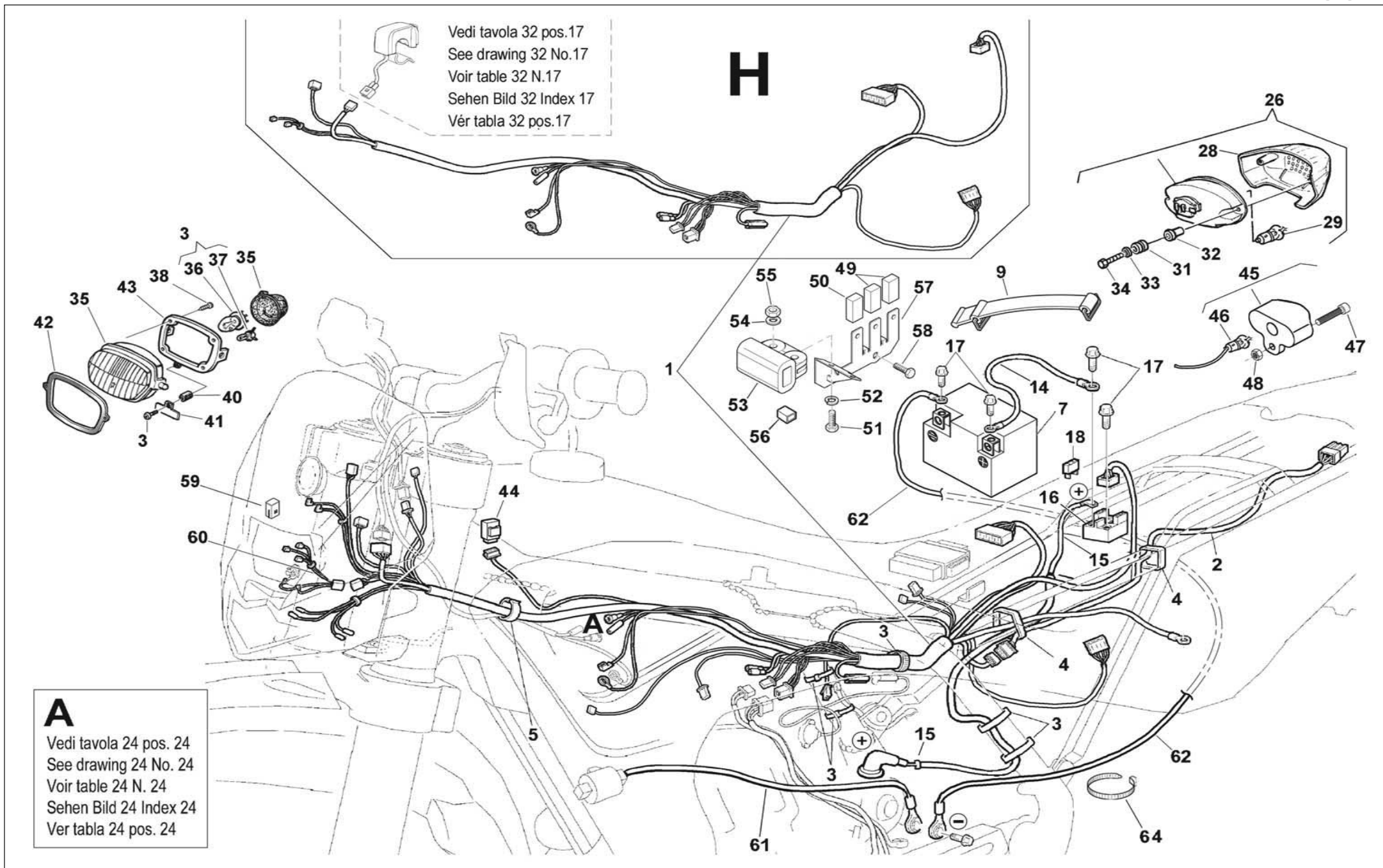

**A**  
 Vedi tavola 24 pos. 24  
 See drawing 24 No. 24  
 Voir table 24 N. 24  
 Sehen Bild 24 Index 24  
 Ver tabla 24 pos. 24

**H**  
 Vedi tavola 32 pos.17  
 See drawing 32 No.17  
 Voir table 32 N.17  
 Sehen Bild 32 Index 17  
 Ver tabla 32 pos.17

Note Notes Notes Marke Notas	Pos. No. N. Index Pos.	N. Cod. Code No. Nr. Code Code Nr N. Cod.	Q.tà Q.ty Q.te M.ge C.ad	DENOMINAZIONE	NAME	DESIGNATION	BESHREIBUNG	DENOMINACION
	1	8000B0252	1	IMPIANTO ELETTRICO	WIRE HARNESS ASSY	FAISCEAU DE FILS	KABELBAUM	CONJUNTO DE CABLES
RACING	1	8000B0146	1	IMPIANTO ELETTRICO	WIRE HARNESS ASSY	FAISCEAU DE FILS	KABELBAUM	CONJUNTO DE CABLES
	2	8000A8497	1	CAVO FANALE POSTERIORE	CABLE, TAILLIGHT	CABLE FEU ARRIERE	KABELBAUM SCHLUSSLICHT	CABLE FARO PILOTO
	3	800056444	16	FASCETTA 188 MM	CLAMP 188 MM	COLLIER 188 MM	SHELLE 188 MM	ABRAZADERA 188 MM
	4	800050005	1	FASCETTA	CLAMP	COLLIER	KLAMMER	ABRAZADERA
	5	800058207	2	PASSACAVO	GUIDE, CABLE 15 MM	PASSE-CABLE 15 MM	KABELDURCHGANG 15 MM	PASACABLES 15 MM
	7	8000A1891	1	BATTERIA 6AH	BATTERY 6AH	BATTERIE 6AH	BATTERIE 6AH	BATERIA 6AH
	9	800077612	1	CINGHIA BATTERIA	BAND, BATTERY	SANGLE BATTERIE	GURTEL, BATTERIE	CORREA BATERIA
	14	8000B0826	1	CAVO BATTERIA-TELERUTTORE	BATTERY-SOLENOID STARTER CABLE	CABLE BATTERIE-TELERUPTUR	KABEL FUR BATTERIE-FERNSCONSOLE	CABLE BATERIA-TELERUPTOR
	15	8000B0827	1	CAVO MOTORINO AVVIAMENTO	CORD STARTER MOTOR	CORDON MOTEUR DEMARRAGE	VERKABELUNG STARTERMOTOR	CABLEADO MOTOR ARRANQUE
	16	800091115	1	TELERUTTORE AVVIAMENTO	RELAY, STARTING MOTOR	RELAIS DEMARRAGE	STARTRELAIS	RELE ARRANQUE
	17	8SA067545	2	VITE TEF M6X1 CH8	SCREW TEF M6X1 CH8	VIS TEF M6X1 CH8	SCHRAUBE TEF M6X1 CH8	TORNILLO TEF M6X CH8
	18	800047473	2	FUSIBILE 15A	FUSE 15A	FUSIBLE 15A	SICHERUNG 15A	FUSIBLE 15A
NO USA	26	8000A8494	1	FANALE POSTERIORE	TAIL LIGHT	FEU ARRIERE	SCHLUSSLICHT	LUZ COLA
NO USA	28	8A0094119	1	LENTE FANALE POSTERIORE	LENS, TAILLIGHT	CABOCHON FEU ARRIERE	RUCKLICHTGLAS	CRISTAL FARO TRASERO
NO USA	29	8A0018246	1	LAMPADINA 12V 5/21W	BULB 12V 5/21W	AMPOULE 12V 5/21W	GLUEHLAMPE 12V 5/21W	LAMPARA 12V 5/21W
NO USA	31	800018048	2	GOMMINO	GROMMET	CAOUTCHOU	GUMMITEILE	GOMA
NO USA	32	8A0094120	2	DISTANZIALE 10X4,2X36,5	SPACER 10X4,2X36,5	ENTRETOISE 10X4,2X36,5	ABSTANDHALTER 10X4,2X36,5	DISTANCIADOR 10X4,2X36,5
NO USA	33	8A0020373	2	RONDELLA 18X4,3X1,5	WASHER 18X4,3X1,5	RONDELLE 18X4,3X1,5	SCHEIBE 18X4,3X1,5	ARANDELA 18X4,3X1,5
NO USA	34	8000A0953	2	VITE TCIC 4X50	SCREW TCIC 4X50	VIS TCIC 4X50	SCHRAUBE TCIC 4X50	TORNILLO TCIC 4X50
NO USA	35	8000A5567	1	FANALE ANTERIORE	HEAD LIGHT	FEU AVANT	SCHEINWERFER	FARO DELANTERO
NO USA	36	800020137	1	LAMPADINA 12V 35/35W BA20D	BULB 12V 35/35W BA20D	AMPOULE 12V 35/35W BA20D	GLUEHLAMPE 12V 35/35W BA20D	LAMPARA 12V 35/35W BA20D
NO USA	37	800026694	1	LAMPADINA 12V 3W	BULB 12V 3W	AMPOULE 12V 3W	GLUEHLAMPE 12V 12V 3W	LAMPARA 12V 12V 3W
NO USA	38	8000A6635	4	VITE	SCREW	VIS	SCHRAUBE	TORNILLO
	40	8A00A1051	1	DISTANZIALE	SPACER	ENTRETOISE	ABSTANDHALTER	DISTANCIADOR
	41	8000A1052	1	PIASTRINA	PLATE	PLAQUETTE	PLAETTCHEN	PLETINA
	42	8000A1053	1	GUARNIZIONE FANALE ANTERIORE	DAMPER, HEADLIGHT	JOINT FEU	SCHEINWERFERDICHTUNG	JUNTA FARO
	43	8000A6484	1	SUPPORTO FANALE ANTERIORE	STAY, HEADLIGHT	SUPPORT FEU AVANT	KONSOLE, SCHEINWERFER	SOPORTE FARO DELANTERO
	44	8000A6749	3	RELE'	RELAY	RELAIS	RELAIS	RELE
	45	8B00A0212	1	FANALE ILLUMINAZIONE TARGA	LAMP, LICENSE PLATE	FEU ECLARAGE PLAQUE IMMATRICULATION	KENNZEICHENLEUCHE	FARO LUZ MATRICULA
	46	800036230	1	LAMPADINA 12V 5W T10	WEDGE BASE BULB 12V5W T10	AMPOULE 12V 5W T10	GLUEHLAMPE 12V 5W T10	LAMPARA 12V 5W T10
	47	60N107330	1	VITE TCEI M5X0,8X16	SCREW TCEI M5X0,8X16	VIS TCEI M5X0,8X16	SCHRAUBE TCEI M5X0,8X16	TORNILLO TCEI M5X0,8X16

